

TECHNICAL MANUAL

**GENERAL SUPPORT MAINTENANCE REPAIR
PARTS AND SPECIAL TOOLS LISTS
FOR**

**MAINTENANCE KITS,
ELECTRONIC EQUIPMENT**

MK-731/ARC-51X

(NSN 6625-00-082-4057)

A N D

MK-731A/ARC-51X

(NSN 6625-00-803-1300)

TECHNICAL MANUAL }
 No. 11-6625-564-40P }

HEADQUARTERS
 DEPARTMENT OF THE ARMY
 WASHINGTON, DC, 15 March 1979

**GENERAL SUPPORT MAINTENANCE REPAIR
 PARTS AND SPECIAL TOOLS LISTS
 FOR
 MAINTENANCE KITS, ELECTRONIC EQUIPMENT
 MK-731/ARC-51X (NSN 6625-00-082-4057)
 AND
 MK-731A/ARC-51X (NSN 6625-00-803-1300)**

Current as of 4 August 1978

REPORTING OF ERRORS

You can improve this manual by recommending improvements using DA Form 2028-2 located in the back of the manual. Simply tear out the self addressed form, fill it out as shown on the sample, fold it where shown, and drop it in the mail.

If there are no blank DA Form 2028-2 in the back of your manual, use the standard DA Form 2028 (Recommended Changes to Publications and Blank Forms) and forward to the Commander, US Army Communications and Electronics Materiel Readiness Command, ATTN: DRSEL-ME-MQ, Fort Monmouth, NJ 07703.

In either case a reply will be furnished direct to you.

Table of Contents

	Page	Illus Figure
S ECTION I. Introduction	1	
Group II. Repair parts list	5	
00 Maintenance Kits, Electronic Equipment MK-731/ARC-51X, MK-731A/ARC-51X	5	1-4
01 Simulators, Test Set, Radio SM-348/ARC-51X, SM-348A/ARC-51X	17	5
0101 Amplifier assembly, audio frequency (761-7040-001)	23	6
0102 Ampifier assembly, audio frequency (761-7041-001)	27	7
010201 Amplifier subassembly (761.7047.001)	29	8
0103 Transient blanking assembly.	31	9
0104 Testgenerator, UHF	35	10, 11
0105 Readout assembly	43	12
0106 Powerconverterasembly	47	13
02 TestSet,RadioTS-1926/ARC-51X	49	14

☛ This manual supersedes TM 11-6625-564-35P, 3 March 1971.

Table of Contents—Continued

	Page	Illus Figure
0201 Test unit	53	15
0202 Detector assembly	57	16
0203 Amplifier assembly, audio frequency (761-7065-001)	61	17
0204 Control, test set	65	18
03 Antenna AS-1484/ARC-51X	67	19
04 Adapter, Connector U-335/ARC-51X	69	20
05 Adapter, Connector U-334/ARC-51X	71	21
06 Dummy Load, Electrical DA-397/ARC-51X	73	22
07 Mounting Tray, Module Extender MT-3372/ARC-51X	75	23
0701 Extender, Module MX-4913/ARC-51X	77	24
0702 Extender, Module MX-4912/ARC-51X	79	25
0703 Extender, Module MX-4911/ARC-51X	81	26
0704 Extender, Module MX-4910/ARC-51X	85	27
0705 Extender, Module MX-4909/ARC-51X	87	28
0706 Extender, Module MX-4908/ARC-51X	89	29
0707 Extender, Module MX-4907/ARC-51X	93	30
0708 Extender, Module MX-4906/ARC-51X	95	31
08 Cable Assembly, Radio Frequency CG-3120/ARC-51X	97	32
09 Cable Assembly, Radio Frequency CG-3119/ARC-51X	99	33
10 Cable Assembly, Radio Frequency CG-3118/ARC-51X	101	34
11 Cable Assembly, Special Purpose, Electrical CX-10191/ARC-51X	103	35
12 Cable Assembly, Special Purpose, Electrical CX-10190/ARC-51X	105	36
13 Cable Assembly, Special Purpose, Electrical CX-10189/ARC-51X	107	37
14 Cable Assembly, Special Purpose, Electrical CX-10188/ARC-51X	109	38
15 Cable Assembly, Special Purpose, Electrical CX-10187/ARC-51X	111	39
16 Cable Assembly, Power, Electrical Branched CX-10186/ARC-51X	113	40
17 Cable Assembly, Special Purpose, Electrical CX-10185/ARC-51X	115	41
18 Cable Assembly, Radio Frequency CX-1889/U	117	42
19 Cable Assembly, Special Purpose, Electrical CX-9053/ARC-51X	119	43
20 Cable Assembly, Special Purpose, Electrical CX-9052/ARC-51X	121	44
SECTION III. Special tools list (Nonapplicable)		
IV. National stock number and part number index	122	

SECTION I

INTRODUCTION

1. Scope

This manual lists spares and repair parts; special tools; special test, measurement, and diagnostic equipment (TMDE), and other special support equipment required for performance of general support maintenance of the MK-731/ARC-51X and MK-731A/ARC-51X. It authorizes the requisitioning and issue of spares and repair parts as indicated by the source and maintenance codes.

2. General

This Repair Parts and Special Tools List is divided into the following sections:

a. Section II. Repair Parts List. A list of spares and repair parts authorized for use in the performance of maintenance. The list also includes parts which must be removed for replacement of the authorized parts. Parts lists are composed of functional groups in numeric sequence, with the parts in each group listed in figure and item number sequence.

b. Section III. Special Tools List. Not applicable.

c. Section IV. National Stock Number and Part Number Index. A list, in National item identification number (NIIN) sequence, of all National stock numbers (NSN) appearing in the listings, followed by a list, in alphameric sequence, of all part numbers appearing in the listings. National stock numbers and part numbers are cross-referenced to each illustration figure and item number appearance.

3. Explanation of Columns

a. Illustration. This column is divided as follows:

(1) *Figure number.* Indicates the figure number of the illustration on which the item is shown.

(2) *Item number.* The number used to identify item called out in the illustration.

b. Source, Maintenance, and Recoverability (SMR) Codes.

(1) *Source code.* Source codes indicate the manner of acquiring support items for maintenance, repair, or overhaul of end items. Source codes are entered in the first and second positions of the Uniform SMR Code format as follows:

<i>Code</i>	<i>Definition</i>
PA-	Item procured and stocked for anticipated or known usage.

XD-A support item that is not stocked. When required, item will be procured through normal supply channels.

NOTE

Cannibalization or salvage may be used as a source of supply for any items source coded above except those coded XA and aircraft support items as restricted by AR 700-42.

(2) *Maintenance code.* Maintenance codes are assigned to indicate the levels of maintenance authorized to USE and REPAIR support items. The maintenance codes are entered in the third and fourth positions of the Uniform SMR Code format as follows:

(a) The maintenance code entered in the third position will indicate the lowest maintenance level authorized to remove, replace, and use the support item. The maintenance code entered in the third position will indicate one of the following levels of maintenance:

<i>Code</i>	<i>Application/Explanation</i>
O-	Support item is removed, replaced, used at the organizational level.
H-	Support item is removed, replaced, used at the general support level.

(b) The maintenance code entered in the fourth position indicates whether the item is to be repaired and identifies the lowest maintenance level with the capability to perform complete repair (i.e., all authorized maintenance functions). This position will contain one of the following maintenance codes:

<i>Code</i>	<i>Application/Explanation</i>
O-	The lowest maintenance level capable of complete repair of the support item is the organizational level.
H-	The lowest maintenance level capable of complete repair of the support item is the general support level.

Z-Nonreparable. No repair is authorized.

(3) *Recoverability code.* Recoverability codes are assigned to support items to indicate the disposition action on unserviceable items. The recoverability code is entered in the fifth position of the Uniform SMR Code format as follows:

<i>Recoverability codes</i>	<i>Definition</i>
Z-	Nonreparable item. When unserviceable, condemn and dispose at the level indicated in position 3.

O-Reparable item. When uneconomically reparable, condemn and dispose at organizational level.

<i>Recoverability codes</i>	<i>Definition</i>
H	Reparable item. When uneconomically reparable, condemn and dispose at the general support level.

c. *National Stock Number.* Indicates the National stock number assigned to the item and will be used for requisitioning purposes.

d. *Part Number.* Indicates the primary number used by the manufacturer (individual, company, firm, corporation, or Government activity), which controls the design and characteristics of the item by means of its engineering drawings, specifications, standards, and inspection requirements to identify an item or range of items.

NOTE

When a stock-numbered item is requisitioned, the repair part received may have a different part number than the part being replaced.

e. *Federal Supply Code for Manufacturer (FSCM).* The FSCM is a 5-digit numeric code listed in SB 708-42 which is used to identify the manufacturer, distributor, or Government agency, etc.

f. *Description.* Indicates the Federal item name and, if required, a minimum description to identify the item.

g. *Unit of Measure (U/M).* Indicates the standard of the basic quantity of the listed item as used in performing the actual maintenance function. This measure is expressed by a two-character alphabetical abbreviation (e.g., ea, in, pr, etc). When the unit of measure differs from the unit of issue, the lowest unit of issue that will satisfy the required units of measure will be requisitioned.

h. *Quantity Incorporated in Unit.* Indicates the quantity of the item used in the breakout shown on the illustration figure, which is prepared for a functional group, subfunctional group, or an assembly.

4. Special Information

a. Usable on codes are shown in the description column. Uncoded items are applicable to all models. Identification of the usable on codes used in this publication are:

<i>Code</i>	<i>Used on</i>
2BH	MK-731/ARC-51X
2CG	MK-731A/ARC-51X

b. *The following publications pertain to the MK-731/ARC-51X, MK-731A/ARC-51X and its components:*

TM 11-6625-564-12, Maintenance Kits, Electronic Equipment MK-731/ARC-51X and MK-731A/ARC-51X

TM 11-6625-564-20P, Maintenance Kits, Electrical Equipment MK-731/ARC-51X and MK-731A/ARC-51X

TM 11-6625-564-45, Maintenance Kits, Electronic Equipment MK-731/ARC-51X and MK-731A/ARC-51X

5. How to Locate Repair Parts

a. When National stock number or part number is unknown.

(1) *First.* Using the table of contents, determine the functional group within which the item belongs. This is necessary since illustrations are prepared for functional groups and listings are divided into the same groups.

(2) *Second* Find the illustration covering the functional group to which the item belongs.

(3) *Third* Identify the item on the illustration and note the illustration figure and item number of the item.

(4) *Fourth-* Using the Repair Parts Listing, find the figure and item number noted on the illustration.

b. When National stock number or part number is known.

(1) *First.* Using the Index of National Stock Numbers and Part Numbers, find the pertinent National stock number or Part number. This index is in N IIN sequence followed by a list of part numbers in alphameric sequence, cross-referenced to the illustration figure number and item number.

(2) *Second* After finding the figure and item number, locate the figure and item number in the repair parts list.

6. Abbreviations

Not applicable.

(Next printed page is 4)

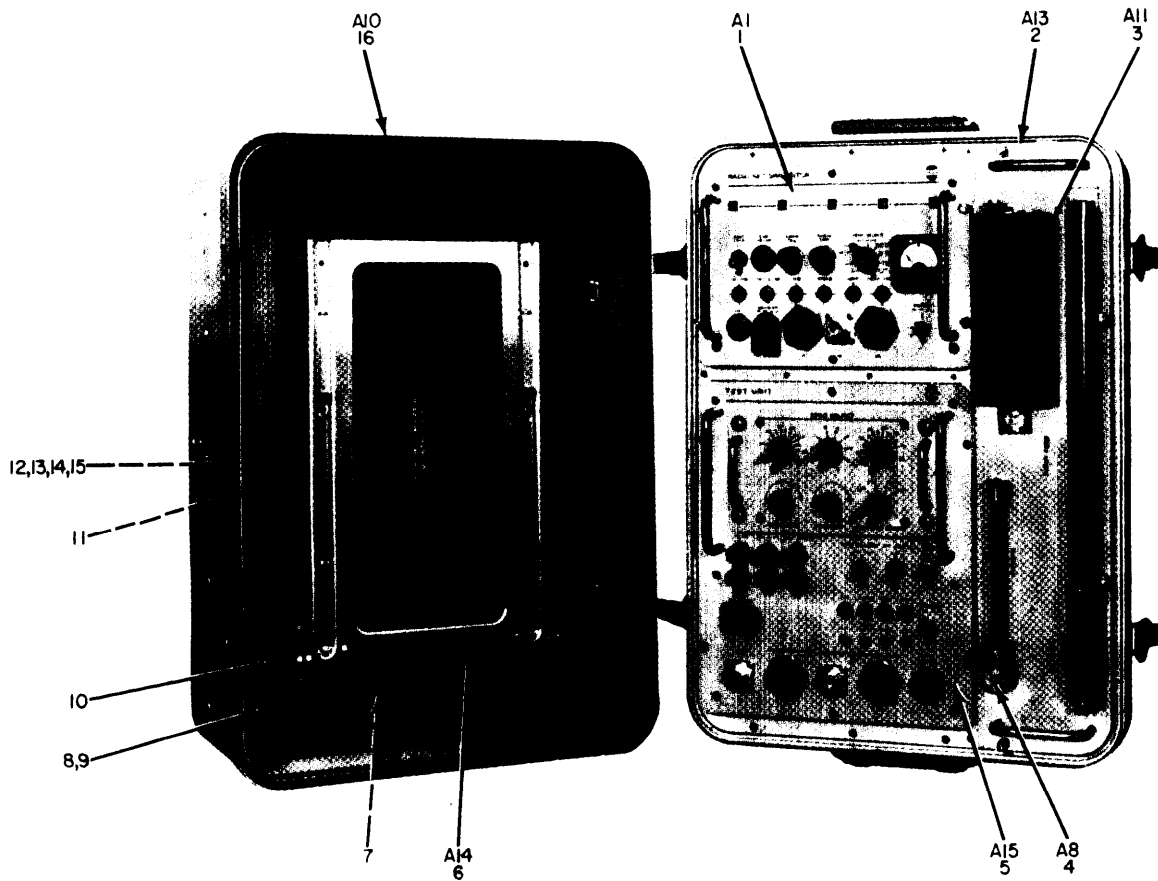

FRONT VIEW , COVER OPEN

NOTE : THE DA-397/ARC-51X IS STORED
IN THE TRANSIT CASE COVER IN
THE MK-731A/ARC-51X.

EL4HK001

Figure 1. Maintenance Kit, Electronic Equipment MK-731/ARC-51X and MK-731A/
ARC-51X (Sheet 1 of 3).

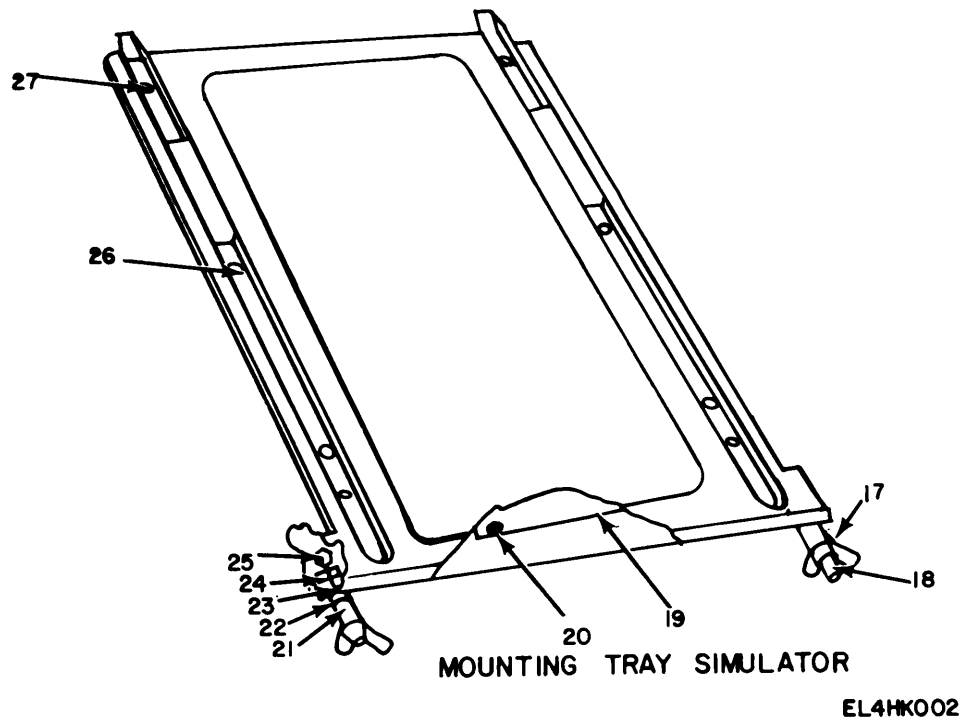

Figure 1. Maintenance Kit, Electronic Equipment MK-731/ARC-51X and MK-731A/ARC-51X (Sheet 2 of 3).

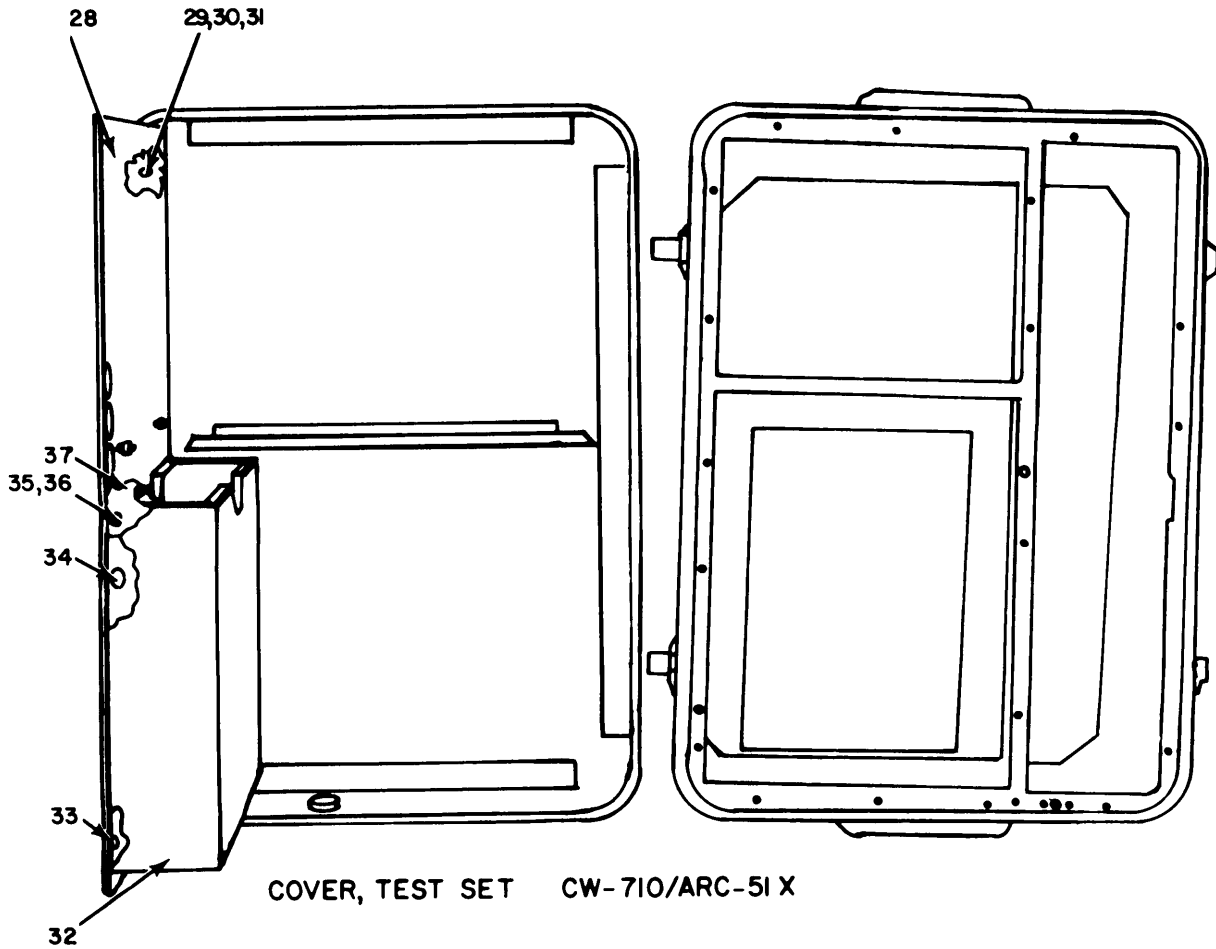

Figure 1. Maintenance Kit, Electronic Equipment MK-731/ARC-51X and MK-731A/ARC-51X (Sheet 3 of 3).

SECTION II

(1) ILLUSTRATION (A) FIG NO	(2) (B) ITEM NO	(3) SMR CODE	(4) NATIONAL STOCK NUMBER	(5) PART NUMBER	(6) FSCM	DESCRIPTION	USABLE ON CODE	(7) U/M	(8) QTY INC IN UNIT
GROUP 00 MAINTENANCE KIT, ELECTRONIC									
EQUIPMENT MK-731/ARC-51X AND									
MK-731A/ARC-51X									
1	1	PAOHH	6625-00-738-5973	SM348ARC51X	80058	SIMULATOR,TEST SET	28H	EA	1
1	1	PAOHH	6625-00-089-7164	SM348AARC51X	80058	SIMULATOR,TEST SET	2CG	EA	1
1	2	XDOOO		MT3372ARC51X	80058	MOUNTING TRAY,MODUL		EA	1
1	3	PAOOO	6625-00-738-5991	DA397ARC51X	80058	DUMMY LOAD,ELECTRIC		EA	1
1	4	PAOOO	5985-00-726-2290	AS1484ARC51X	80058	ANTENNA		EA	1
1	5	PAOOO	6625-00-965-1483	TS1962ARC51X	80058	TEST SET,RADIO		EA	1
1	6	PAOOO	6625-00-738-5976	MT3371ARC51X	80058	MOUNTING TRAY,SIMUL		EA	1
1	7	PAOOO	5180-00-738-6019	TK155ARC51X	80058	TOOL KIT,RADIO SET		EA	1
1	8	PAHZZ	5305-00-054-5636	MS51957-2	96906	SCREW,MACHINE		EA	6
1	9	PAHZZ	5310-00-928-2690	MS35338-134	96906	WASHER,LOCK		EA	6
1	10	XDHZZ		756-9057-001	13499	SCALE,ANTENNA		EA	1
1	11	XDOZZ		757-9783-000	13499	PLATE,IDENT		EA	1
1	12	PAOZZ	5310-00-938-2013	MS35649-24	96906	NUT,PLAIN,HEXAGON		EA	4
1	13	PAOZZ	5305-00-054-5638	MS51957-4	96906	SCREW,MACHINE		EA	4
1	14	PAOZZ	5310-00-907-0959	310-6320-000	79807	WASHER,FLAT		EA	4
1	15	PAOZZ	5310-00-928-2690	MS35338-134	96906	WASHER,LOCK		EA	4
1	16	XDHHH		CW710ARC51X	80058	COVER,TEST SET		EA	1
1	17	PADZZ	5310-00-550-3715	MS35333-70	96906	WASHER,LOCK		EA	2
1	18	PAOZZ	5306-00-924-0654	547-1646-002	13499	BOLT,TEE HEAD		EA	2
1	19	XDOZZ		767-0754-008	13499	PLATE,IDENT		EA	1
1	20	PAOZZ	5310-00-938-2013	MS35649-24	96906	NUT,PLAIN,HEXAGON		EA	2
1	21	XDOZZ		756-9043-001	13499	SPACER,SLEEVE		EA	4
1	22	PAOZZ	5365-00-695-2558	340-0642-00	91314	RING,RETAINING		EA	4
1	23	XDOZZ		547-1647-002	13499	PIN,STRAIGHT,HEADLE		EA	2
1	24	PAOZZ	5310-00-881-1624	334-1656-00	06164	NUT,PLAIN,HEXAG		EA	2
1	25	PAOZZ	3040-00-016-2719	547-1643-002	13499	BALL,BALL JOINT		EA	2
1	26	PAOZZ	5305-00-054-6672	MS51957-47	96906	SCREW,MACHINE		EA	4
1	27	PAOZZ	5305-00-764-2966	MS51959-2	96906	SCREW,MACHINE		EA	4
1	28	XDHZZ		756-9054-001	13499	HINGE,BUTT		EA	1
1	29	XDHZZ		756-9051-001	13499	NUT,STRIP,HINGE		EA	2
1	30	PAHZZ	5305-00-054-5648	MS51957-14	96906	SCREW,MACHINE		EA	16
1	31	PAHZZ	5310-00-933-8118	MS35338-135	96906	WASHER,LOCK		EA	16
1	32	XDHZZ		756-9059-001	13499	RACK,BOOK-WELDE		EA	1
1	33	PAHZZ	5305-00-763-6963	MS51959-28	96906	SCREW,MACHINE		EA	4
1	34	XDHZZ		756-9058-001	13499	NUT,STRIP,BOOK		EA	2
1	35	PAHZZ	5305-00-054-6652	MS51957-28	96906	SCREW,MACHINE		EA	4
1	36	PAHZZ	5310-00-929-6395	MS35338-136	96906	WASHER,LOCK		EA	4

SECTION II

(1)	(2)	(3)	(4)	(5)	(6)	(7)	(8)	
ILLUSTRATION							QTY	
(A)	(B)		NATIONAL		DESCRIPTION		INC	
FIG	ITEM	SMR	STOCK	PART			IN	
NO	NO	CODE	NUMBER	NUMBER	FSCM	USABLE ON CODE	U/M	
							UNIT	
1	37	XDHZZ		756-9050-001	13499	PAD,RACK,BOOK	EA	2

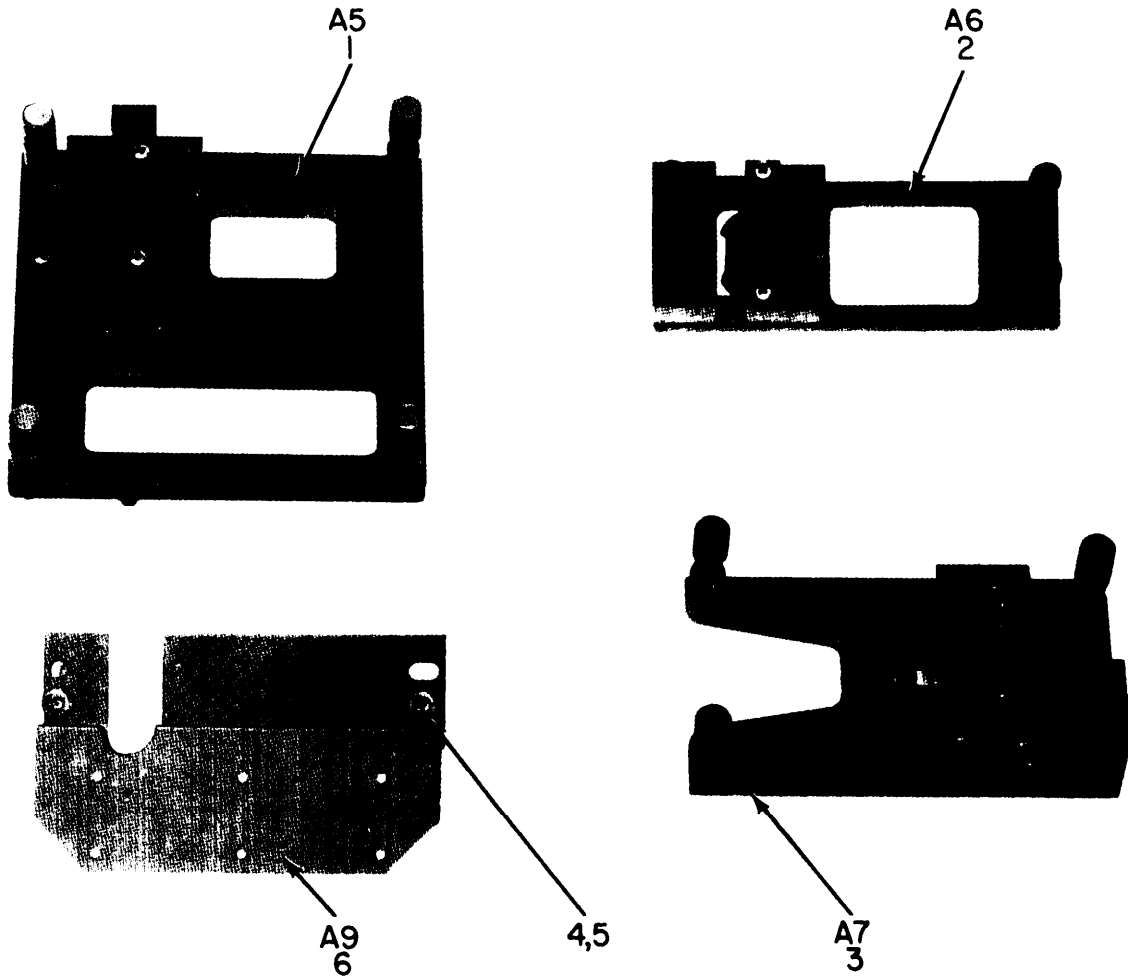

EL4HK004

Figure 2. Maintenance Kit, Electronic Equipment MK-731/ARC-51X and 'MI(-731A/ARC-51X, Alignment Fixtures and Locking Block.

SECTION II

(1)	(2)	(3)	(4)	(5)	(6)	(7)	(8)	
ILLUSTRATION							QTY	
(A)	(B)	NATIONAL			DESCRIPTION		INC	
FIG	ITEM	SMR	STOCK	PART			IN	
NO	NO	CODE	NUMBER	NUMBER	FSCM	USABLE ON CODE	U/M	
							UNIT	
2	1	PAOZZ	6625-00-738-5989	MX6733ARC51X	80058	ALIGNMENT FIXTURE	EA	1
2	2	PAOZZ	6625-00-738-5986	MX6734ARC51X	80058	ALIGNMENT FIXTURE	EA	1
2	3	PAOZZ	6625-00-738-5990	MX6732ARC51X	80058	ALIGNMENT FIXTURE	EA	1
2	4	PAOZZ	5305-00-054-5651	MS51957-17	96906	SCREW,MACHINE	EA	2
2	5	PAOZZ	5365-00-717-8566	340-0644-000	91314	SLEEVE,SPRING	EA	2
2	6	PAOOO	6625-00-738-5984	MX6731ARC51X	80058	BLOCK,LOCKING	EA	1

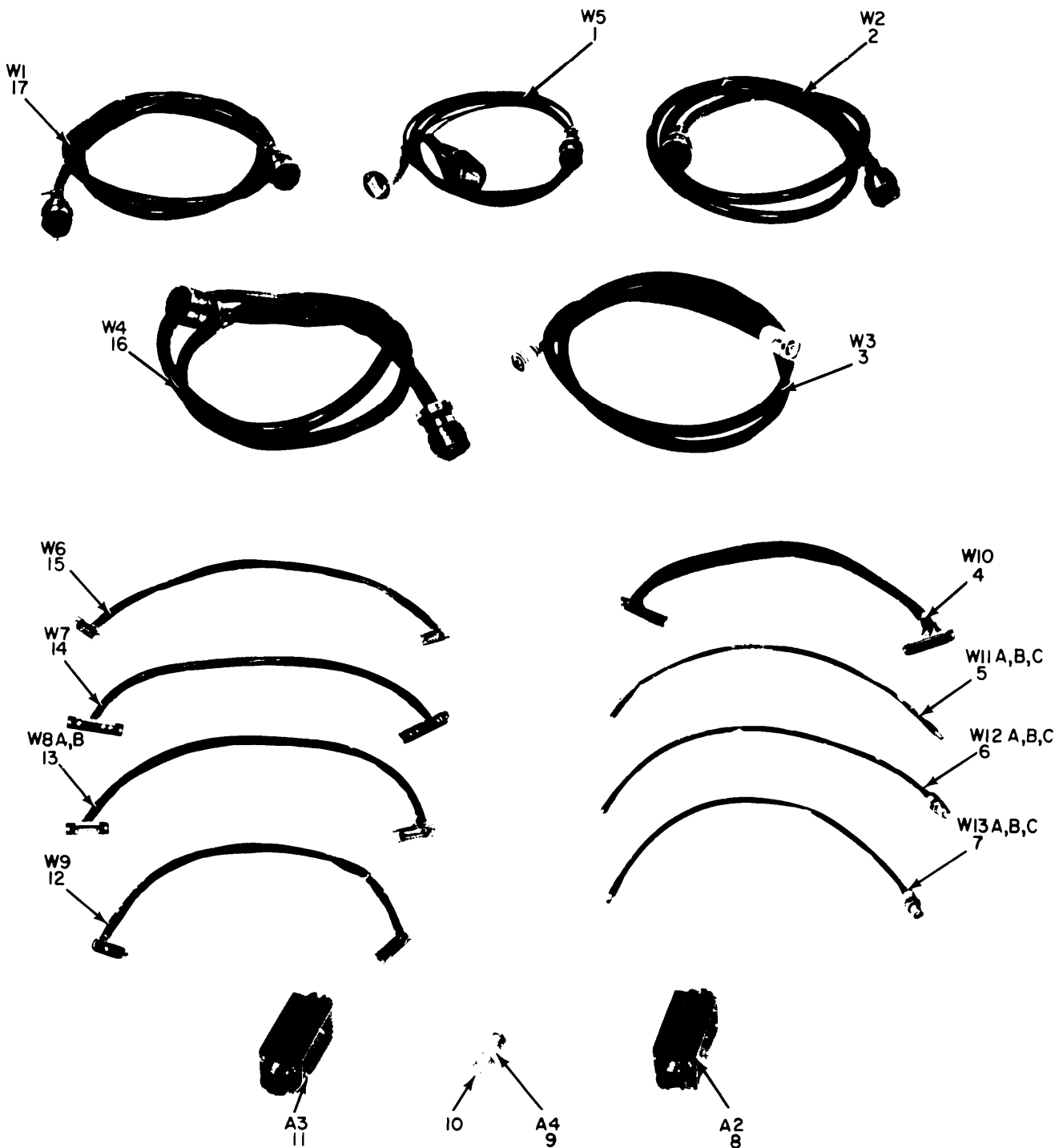

EL4HK005

Figure 3. Maintenance Kit, Electronic Equipment MK-731/ARC-51X and MK-731A/ARC-51X, Cable Assemblies and Adapters.

SECTION II

(1) ILLUSTRATION (A) FIG NO	(2) (B) ITEM NO	(3) SMR CODE	(4) NATIONAL STOCK NUMBER	(5) PART NUMBER	(6) FSCM	(7) DESCRIPTION	(8) USABLE ON CODE	(9) U/M	(10) QTY INC IN UNIT
3	1	PA000	6625-00-738-5985	CX10186ARC51X6FT	80058	CABLE ASSEMBLY		EA	1
3	2	PA000	6625-00-985-8083	CX9053ARC51X	80058	CABLE ASSEMBLY,SPEC		EA	1
3	3	PA000	5995-00-467-3887	CG1889U5FT	80058	CABLE ASSEMBLY,RADI		EA	1
3	4	PA000	5995-00-985-8081	CX10191ARC51X	80058	CABLE ASSEMBLY,SPEC		EA	1
3	5	PA000	6625-00-985-8078	CG3118ARC51X	80058	CABLE ASSEMBLY,RADI		EA	3
3	6	PA000	6625-00-985-8079	CG3119ARC51X	80058	CABLE ASSEMBLY,RADI		EA	3
3	7	PA000	6625-00-985-8080	CG3120ARC51X	80058	CABLE ASSEMBLY,RADI		EA	3
3	8	PA000	5935-00-762-9306	U335ARC51X	80058	ADAPTER,TEST		EA	1
3	9	PA000	5935-01-035-5650	U336ARC51X	80058	ADAPTER,CONNECTOR		EA	1
3	10	PAOZZ	5935-00-643-9875	U29BU	80058	ADAPTER,CONNECT		EA	1
3	11	PA000	5935-00-762-9307	U334ARC51X	80058	ADAPTER,CONNECTOR		EA	1
3	12	PA000	6625-00-985-8088	CX10190ARC51X	80058	CABLE ASSEMBLY,SPEC		EA	1
3	13	PA000	6625-00-935-8641	CX10189ARC51X	80058	CABLE ASSY,SP,E		EA	2
3	14	PA000	6625-00-985-8086	CX10188ARC51X	80058	CABLE ASSEMBLY,SPEC		EA	1
3	15	PA000	6625-00-985-8085	CX10187ARC51X	80058	CABLE ASSEMBLY,SPEC		EA	1
3	16	PA000	6625-00-985-8084	CX10185ARC51X	80058	CABLE ASSEMBLY,SPEC		EA	1
3	17	PA000	6625-00-985-8082	CX9052ARC51X	80058	CABLE ASSEMBLY,SPEC		EA	1

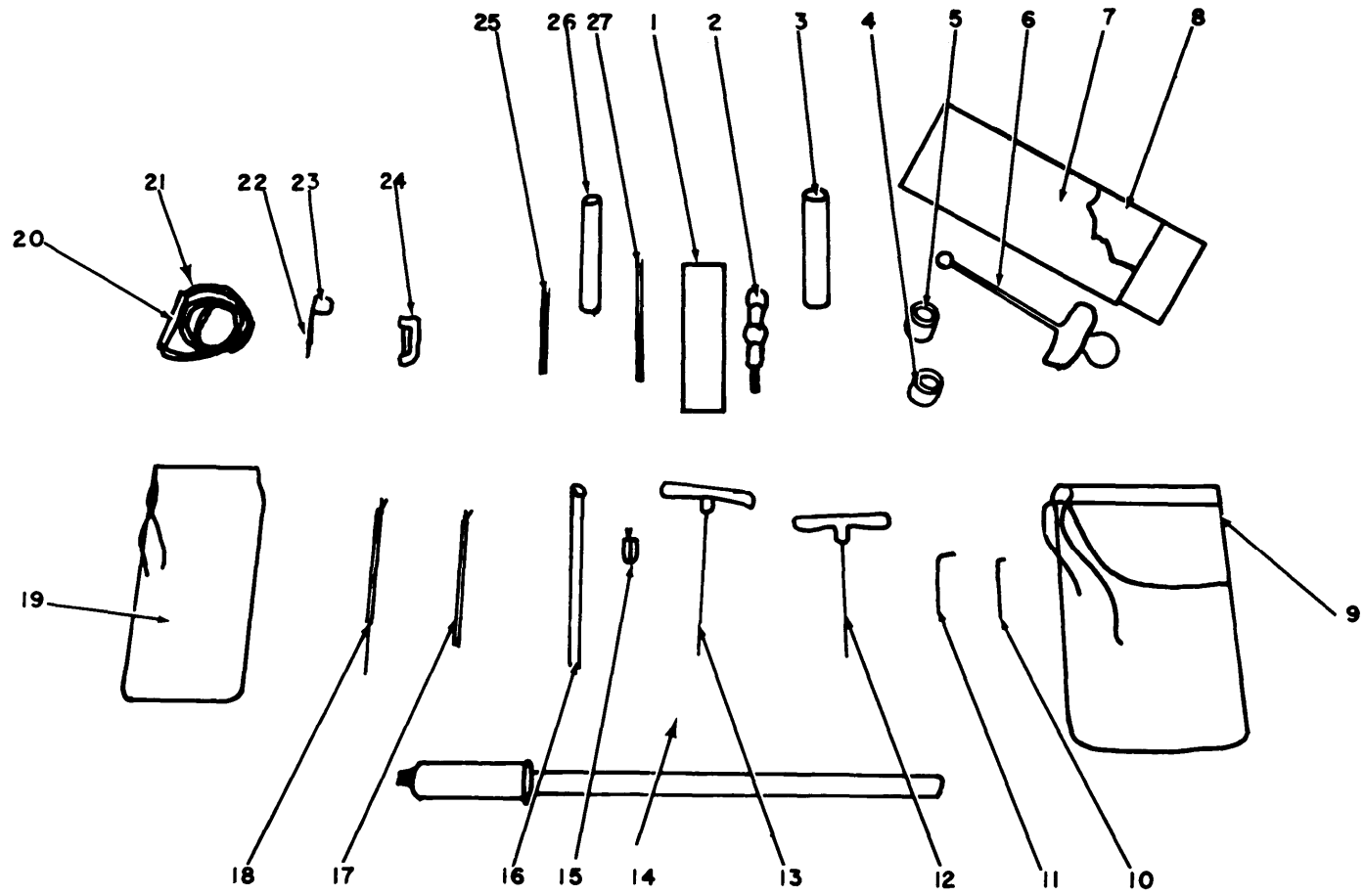

**NOTE: FOR COMPLETE REFERENCE DESIGNATION
PREFIX WITH A16.**

EL4HK006

Figure 4. Maintenance Kit, Electronic Equipment MK-731/ARC-51X and MK-731A/ARC-51X, Tool Kits Radio Set.

SECTION II

(1) ILLUSTRATION (A) FIG NO	(2) ITEM (B) NO	(3) SMR CODE	(4) NATIONAL STOCK NUMBER	(5) PART NUMBER	(6) FSCM	(7) DESCRIPTION	(8) QTY INC IN UNIT
							USABLE ON CODE U/M
4	1	PAOZZ	5120-00-152-2516	761-5944-001	13499	CUSHION EXTENSION	EA 1
4	2	PAOZZ	5120-00-963-7661	CETC6B	71468	REMOVAL TOOL, CONNE	EA 1
4	3	PAOZZ	5140-00-152-2514	024-0628-020	13499	CONTAINER, TOOL	EA 1
4	4	PAOZZ	5120-00-906-6377	756-7580-001	13499	SOCKET WRENCH	EA 1
4	5	PAOZZ	5120-00-906-6379	756-7579-001	13499	SOCKET WRENCH	EA 1
4	6	PAOZZ	5120-00-618-4433	F10-1	26848	WRENCH,TORQUE	EA 1
4	7	PAOZZ	5140-00-944-7206	761-5947-001	13499	CASE TORQUE WRENCH	EA 1
4	8	PAOZZ	5140-00-944-7205	761-5945-001	13499	COVER TORQUE WRENCH	EA 1
4	9	XDOZZ		024-0642-010	13499	BAG,COTTON DUCK	EA 1
4	10	PAOZZ	5120-00-908-4752	544-8398-002	13499	KEY,SOCKET HEAD SCR	EA 1
4	11	PAOZZ	5120-00-952-0108	GT1003	70276	KEY,SCH,SCREW	EA 1
4	12	PAOZZ	5120-00-995-9045	GGGK275	81348	KEY,SCH,SCREW	EA 1
4	13	PAOZZ	5120-00-198-5401	050	08644	KEY,SCH,SCREW	EA 1
4	14	PAOZZ	4320-00-854-4444	6A49450	53800	PUMP,INFLATING	EA 1
4	15	PAOZZ	5935-00-959-1457	544-8352-002	13499	SHIELD,ELECTRICAL C	EA 1
4	16	PAOZZ	4910-00-908-6709	7229	17875	GAUGE,PRESSURE	EA 1
4	17	PAOZZ	5120-00-720-1908	024-0168-00	13499	ALIGNMENT TOOL,ELEC	EA 1
4	18	PAOZZ	5120-00-013-7117	548-9286-002	13499	ALIGNMENT TOOL,ELEC	EA 1
4	19	PAOZZ	8105-00-753-4589	024-0137-00	13499	BAG,COTTON DUCK	EA 1
4	20	PAOZZ	5935-00-617-6837	SKT10WHT	98291	JACK,TIP	EA 1
4	21	PAOZZ	5935-00-990-6983	203B	83330	PLUG,TIP	EA 1
4	22	PAOZZ	5315-00-297-0875	MS171444	96906	PIN,SPRING	EA 1
4	23	PAOZZ	5120-00-022-7793	548-2214-002	13499	ALIGNMENT TOOL,ROTO	EA 1
4	24	PAOZZ	5120-00-906-6380	756-7571-001	13499	ANVIL	EA 1
4	25	PAOZZ	5120-00-906-6376	553-9709-002	13499	PIN,DRIFT	EA 1
4	26	PAOZZ	5140-00-906-6373	024-0628-010	13499	CONTAINER,TOOL	EA 1
4	27	PAOZZ	5120-00-908-4754	544-8357-002	13499	ALIGNMENT TOOL	EA 1

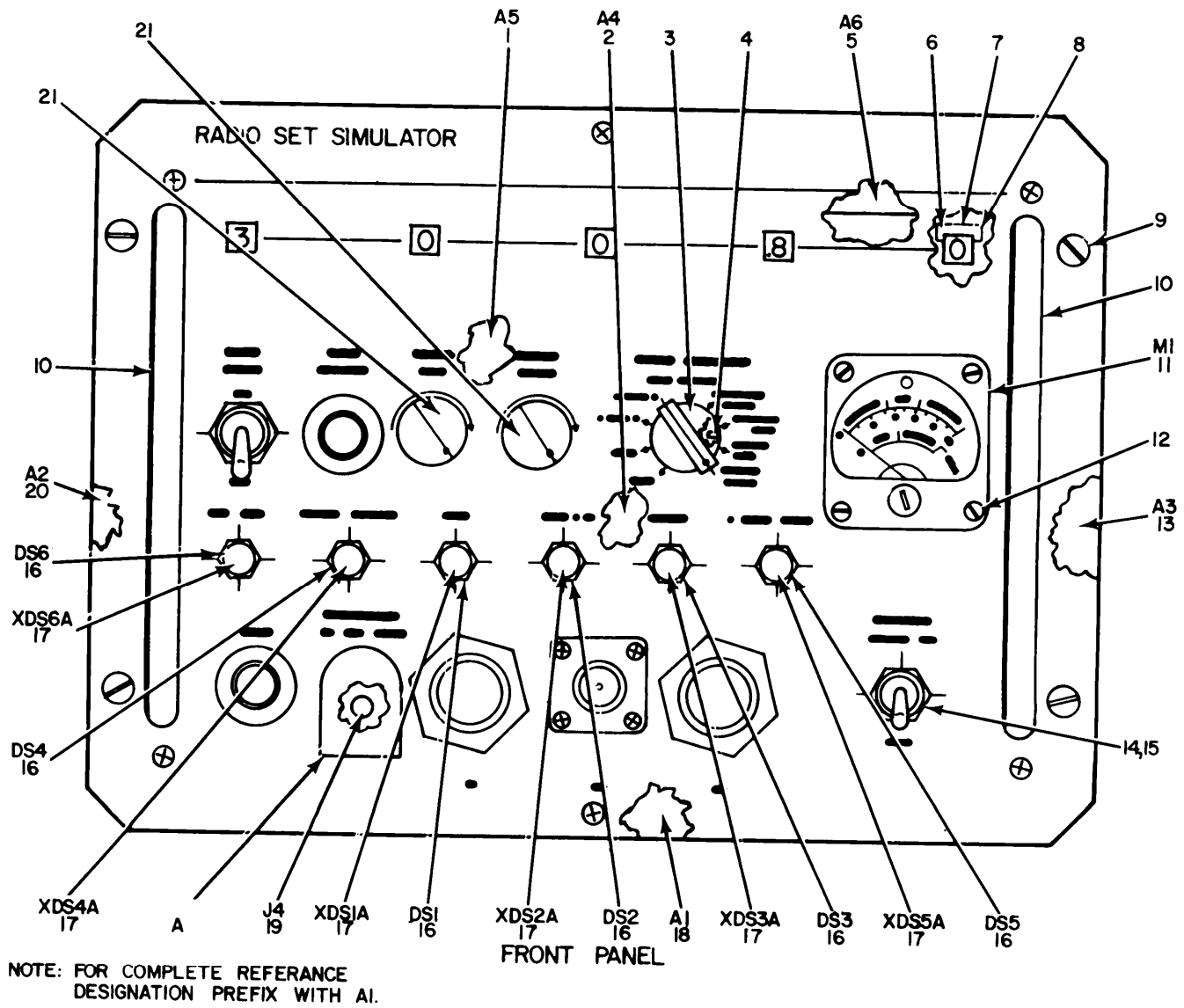

EL4HK007

Figure 5. Simulators, Test Set, Radio SM-348/ARC-51X and SM-348A/ARC-51X (Sheet 1 of 3).

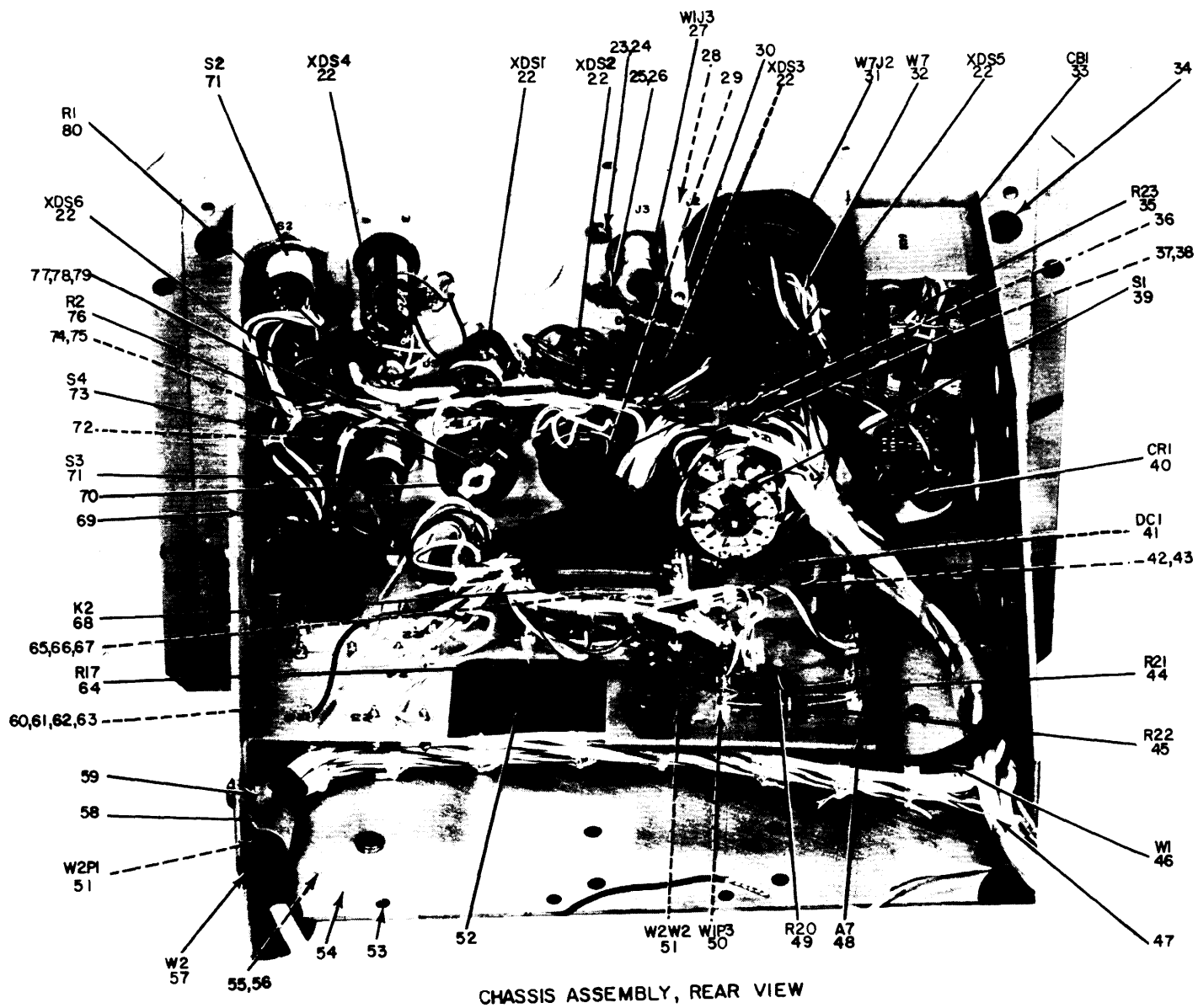

EL4HK008

Figure 5. Simulators, Test Set, Radio SM-348/ARC-51X and SM-348A/ARC-51X (Sheet 2 of 3).

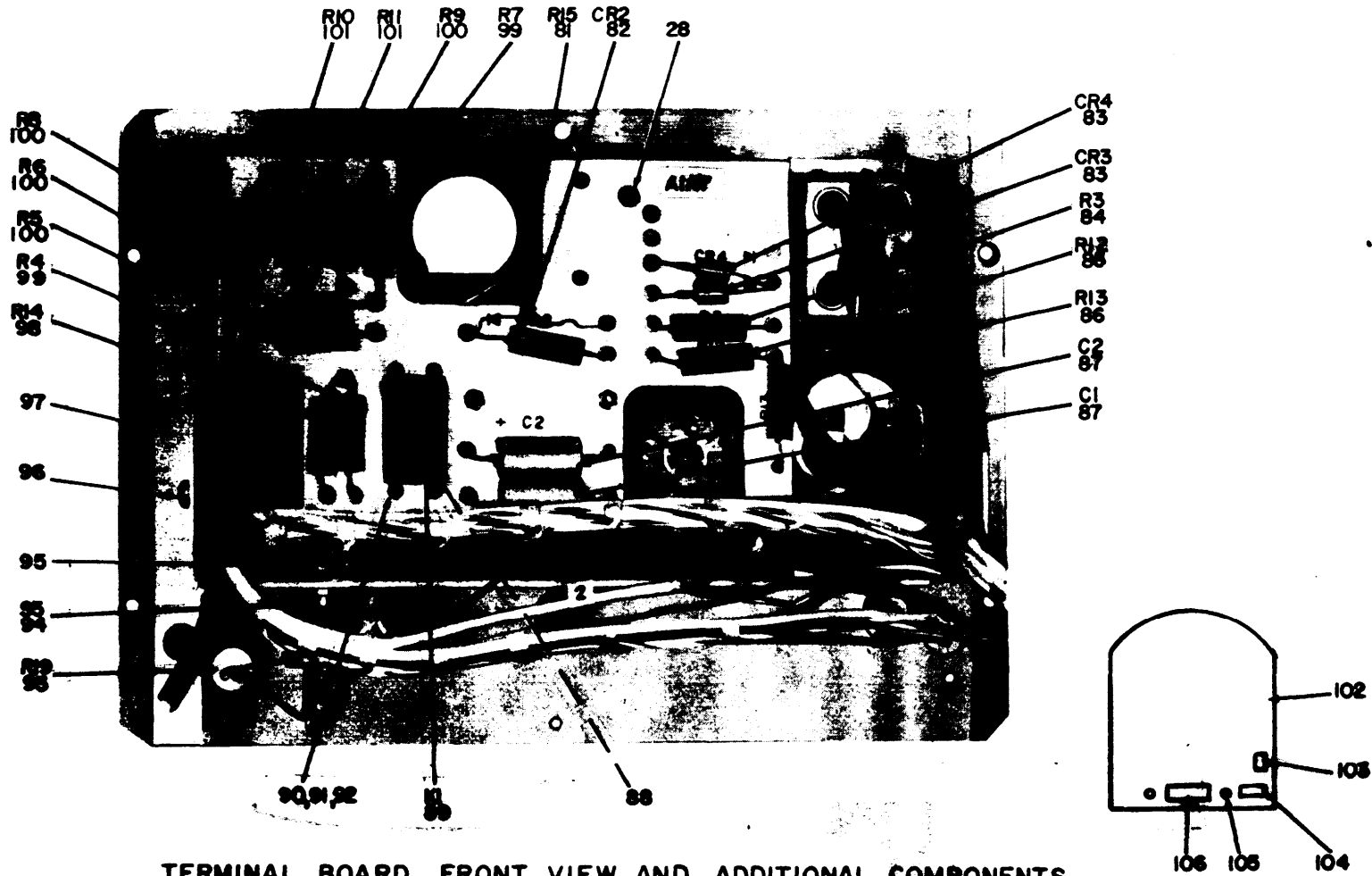

TERMINAL BOARD, FRONT VIEW AND ADDITIONAL COMPONENTS

NOTE: FOR COMPLETE REFERENCE DESIGNATION PREFIX WITH AIA7

Figure 5. Simulators, Test Set, Radio SM-348/ARC-51X and SM-348A/ARC-51X (Sheet 3 of 3).

SECTION II

(1) ILLUSTRATION (A) FIG NO	(2) (B) ITEM NO	(3) SMR CODE	(4) NATIONAL STOCK NUMBER	(5) PART NUMBER	(6) FSCM	(7) DESCRIPTION USABLE ON CODE	(8) QTY INC IN UNIT U/M
GROUP 01 SIMULATOR, TEST SET, RADIO							
SM-348/ARC-51X, SM-348A/ARC-51X							
5	1	PAOHH	6625-00-906-6366	761-7044-001	13499	TEST GENERATOR, ULTRA 2BH	EA 1
5	1	PAOHH	6625-00-143-6716	775-2711-001	13499	GENERATOR, SIGNAL 2CG	EA 1
5	2	PAOHH	6625-00-908-7393	761-7043-001	13499	TRANSIENTBLANKER	EA 1
5	3	PAOZZ	5355-00-908-4763	757-0230-001	13499	KNOB	EA 1
5	4	PAOZZ	5305-00-719-5342	MS51981-26	96906	SETSCREW	EA 6
5	5	PAOHH	6625-00-906-6367	761-7062-001	13499	READOUT	EA 1
5	6	XDHZZ		756-9208-001	13499	WINDOW, DIAL	EA 5
5	7	PAHZZ	6625-00-823-5348	756-9207-001	13499	GASKET	EA 5
5	8	PAHZZ	5365-00-857-1960	5005-62	79136	RING, RETAINING	EA 5
5	9	XDHZZ		761-7024-001	13499	SCREW, SPECIAL	EA 4
5	10	XDHZZ		2102	86577	HANDLE, BOW	EA 2
5	11	PAHZZ	6625-00-908-7392	476-0386-000	13499	METER, ARBITRARY SCA	EA 1
5	12	PAHZZ	5305-00-207-7468	MS35214-16	96906	SCREW, MACHINE	EA 4
5	13	PAOHH	6625-00-908-7386	761-7042-001	13499	CONVERTER, POWER	EA 1
5	14	XDHZZ		505-1504-001	13499	WASHER, FLAT	EA 3
5	15	PAHZZ	5310-00-883-5931	410894-38	96214	WASHER, LOCK	EA 9
5	16	PAOZZ	6240-00-155-7836	MS25237-327	96906	LAMP, INCANDESCENT	EA 6
5	17	PAOZZ	6210-00-767-6246	855020R	08717	LENS, IND, LIGHT	EA 6
5	18	PAOHH	6625-00-906-6365	761-7040-001	13499	AMPLIFIER, AUDIO FRE	EA 1
5	19	PAHHH	5935-00-906-6334	756-8876-001	13499	JACK, TIP	EA 1
5	20	PAOHH	6625-00-908-7385	761-7041-001	13499	AMPLIFIER, AUDIO FRE	EA 1
5	21	PAOZZ	5355-00-909-0465	757-0228-001	13499	KNOB	EA 2
5	22	PAHZZ	6210-00-881-1507	855029-9	08717	LIGHT, INDICATOR	EA 6
5	23	PAHZZ	5310-00-493-1738	P313-0051-00	77250	NUT, PLAIN, HEXAGON	EA 3
5	24	PAHZZ	5305-00-207-7465	P343-0287-00	77250	SCREW, MACHINE	EA 2
5	25	PAHZZ	5305-00-207-7463	P343-0288-00	77250	SCREW, MACHINE	EA 2
5	26	PAHZZ	5310-00-184-8996	310009500	70117	WASHER, LOCK	EA 5
5	27	PAHZZ	5935-00-969-6996	101N3100A25	94375	CONNECTOR, RECEPTACL	EA 1
5	28	PAHZZ	5305-00-054-5648	MS51957-14	96906	SCREW, MACHINE	EA 5
5	29	PAHZZ	5310-00-275-5147	P334-4120-00	77250	NUT, PLAIN, HEXAGON	EA 2
5	30	XDHZZ		540-9059-003	13499	POST, ELECTRICAL-MEC	EA 1
5	31	PAHZZ	5935-00-836-1804	MS3114E16-26P	96906	CONNECTOR, RECEPTACL	EA 1
5	32	XDHHH		761-7030-001	13499	WIRING HARNESS	EA 1
5	33	PAHZZ	5925-00-918-3023	1163S50-125VDC3	74193	CIRCUIT, BREAKER	EA 1
5	34	PAHZZ	5305-00-071-1320	MS35201-53	96906	SCREW, MACHINE	EA 4
5	35	XDHZZ		NX24428	71450	RESISTOR, VARIABLE, W	EA 1
5	36	PAHZZ	5821-00-785-6853	541-5187-002	13499	BUTTON CABLE	EA 1

SECTION II

(1) ILLUSTRATION (A) FIG NO	(2) ITEM NO	(3) SMR CODE	(4) NATIONAL STOCK NUMBER	(5) PART NUMBER	(6) FSCM	(7) DESCRIPTION USABLE ON CODE	(8) QTY INC IN UNIT
5	37	PAHZZ	5305-00-054-5651	MS51957-17	96906	SCREW,MACHINE	EA 1
5	38	PAHZZ	5310-00-782-1349	310-0045-00	79807	WASHER,FLAT	EA 1
5	39	XDHZZ		237617BA3	76854	SWITCH,ROTARY	EA 1
5	40	PAHZZ	5961-00-985-4900	JAN1N647	81349	SEMICONDUCTOR,D	EA 1
5	41	PAHZZ	5985-00-824-3677	4161F	70998	COUPLER,DIRECTIONAL	EA 1
5	42	PAHZZ	5305-00-054-6650	MS51957-26	96906	SCREW,MACHINE	EA 4
5	43	PAHZZ	5310-00-929-6395	MS35338-136	96906	WASHER,LOCK	EA 4
5	44	PAHZZ	5905-00-299-1971	RC20GF822J	81349	RESISTOR,FIXED,COMP	EA 1
5	45	PAHZZ	5905-00-195-6761	RC20GF104J	81349	RESISTOR,FIXED,COMP	EA 1
5	46	XDHHH		761-7036-001	13499	CABLE,SP	EA 1
5	47	PAHZZ	5340-00-003-6667	HP8N	09922	CLAMP,LOOP	EA 1
5	48	PAHHH	6625-00-908-7401	761-7034-001	13499	ELECTRONIC COMPONEN	EA 1
5	49	PAHZZ	5905-00-195-6806	RC20GF102J	81349	RESISTOR,FIXED,COMP	EA 1
5	50	PAHZZ	5935-00-823-0487	MS35168-88E	96906	CONNECTOR,PLUG,ELEC	EA 1
5	51	PAHZZ	5935-00-823-0487	MS35168-88E	96906	CONNECTOR,PLUG,ELEC	EA 2
5	52	XDHZZ		756-9211-001	13499	GUARD,GENERATOR	EA 1
5	53	PAHZZ	5310-00-208-3786	P313-0132-00	77250	NUT,PLAIN,HEXAGON	EA 11
5	54	XDHZZ		761-7032-001	13499	PLATE,MTG,UHF G	EA 1
5	55	PAHZZ	5310-00-857-5548	MS21044D04	96906	NUT,SELF-LOCKING,HE	EA 2
5	56	PAHZZ	5305-00-763-7822	MS51959-14	96906	SCREW,MACHINE	EA 2
5	57	XDHHH		761-7037-001	13499	CABLE,SP,ELEC	EA 1
5	58	PAHZZ	5340-00-975-1440	HP6N	09922	CLAMP,LOOP	EA 2
5	59	PAHZZ	5310-00-857-5547	MS21044D06	96906	NUT,SELF-LOCKING,HE	EA 3
5	60	PAHZZ	5310-00-938-2013	MS35649-24	96906	NUT,PLAIN,HEXAGON	EA 8
5	61	XDHZZ		F22NA1K82	72962	NUT,SLFLKG,PL	EA 4
5	62	PAHZZ	5305-00-764-2964	MS51959-4	96906	SCREW,MACHINE	EA 8
5	63	PAHZZ	5310-00-928-2690	MS35338-134	96906	WASHER,LOCK	EA 10
5	64	PAHZZ	5905-00-820-4357	224P1-503	80294	RESISTOR,VARIABLE,W	EA 1
5	65	PAHZZ	5310-00-208-3786	P313-0132-00	77250	NUT,PLAIN,HEXAGON	EA 2
5	66	PAHZZ	5305-00-054-5647	MS51957-13	96906	SCREW,MACHINE	EA 2
5	67	PAHZZ	5310-00-933-8118	MS35338-135	96906	WASHER,LOCK	EA 2
5	68	PAHZZ	5945-00-086-8876	BR7X300D2S3-26V	802050	RELAY,ARMATURE	EA 1
5	69	PAHZZ	5940-00-738-1265	547-5305-002	13499	TERMINAL,LUG	EA 1
5	70	XDHZZ		756-9206-001	13499	BUSHING,SLEEVE	EA 1
5	71	PAHZZ	5930-00-504-6223	MS25089-4C	96906	SWITCH,PUSH	EA 2
5	72	PAHZZ	5940-00-878-3768	4007-6	77147	TERMINAL,LUG	EA 4
5	73	PAHZZ	5930-00-685-9521	MS35059-30	96906	SWITCH,TOGGLE	EA 1
5	74	XDHZZ		761-0012-003	13499	WASHER,FLAT	EA 1
5	75	XDHZZ		1A1S4H2	79807	WASHER,LOCK	EA 4
5	76	XDHZZ		E4190R1	44655	RESISTOR,VARIABLE,W	EA 1

SECTION II

(1) ILLUSTRATION (A) FIG NO	(2) ITEM (B) NO	(3) SMR CODE	(4) NATIONAL STOCK NUMBER	(5) PART NUMBER	(6) FSCM	DESCRIPTION	USABLE ON CODE	(7) U/M	(8) QTY INC IN UNIT
5	77	PAHZZ	5310-00-924-8526	P334-0287-00	77250	NUT, PLAIN, HEXAGON		EA	1
5	78	XDHZZ		542-1560-003	13499	WASHER, FLAT		EA	1
5	79	PAHZZ	5310-00-811-0494	1714-05	78189	WASHER, LOCK		EA	1
5	80	XDHZZ		RW67VL51	81349	RESISTOR, FXD, WW		EA	1
5	81	PAHZZ	5905-00-845-9472	RN70C4223F	81349	RESISTOR, FIXED, FILM		EA	1
5	82	PAHZZ	5961-00-985-4900	JAN1N647	81349	SEMICONDUCTOR, D		EA	1
5	83	PAHZZ	5961-00-837-9288	1N3029B	80131	SEMICONDUCTOR DEVIC		EA	2
5	84	PAHZZ	5905-00-801-1217	RN70C2373F	81349	RESISTOR, FIXED, FILM		EA	1
5	85	PAHZZ	5905-00-802-0898	RN70C1102F	81349	RESISTOR, FIXED, FILM		EA	1
5	86	PAHZZ	5905-00-726-7545	RN70C3833F	81349	RESISTOR, FIXED, FILM		EA	1
5	87	XDHZZ		SDA3K01104M	53021	CAPACITOR, FXD, P		EA	2
5	88	XDHZZ		541-5950-002	13499	SPACER, SLEEVE		EA	4
5	89	PAHZZ	5945-00-880-8747	RY4N4B3L	81349	RELAY, ARMATURE		EA	1
5	90	PAHZZ	5310-00-938-2013	MS35649-24	96906	NUT, PLAIN, HEXAGON		EA	6
5	91	PAHZZ	5305-00-054-5640	MS51957-6	96906	SCREW, MACHINE		EA	6
5	92	PAHZZ	5310-00-928-2690	MS35338-134	96906	WASHER, LOCK		EA	4
5	93	XDHZZ		RH50-2R000G	91637	RESISTOR, FXD, WW		EA	1
5	94	PAHZZ	5925-00-556-7530	PSA2	82647	CIRCUIT BREAKER		EA	1
5	95	PAHZZ	5305-00-054-6652	MS51957-28	96906	SCREW, MACHINE		EA	15
5	96	PAHZZ	5305-00-770-2533	MS51959-13	96906	SCREW, MACHINE		EA	6
5	97	PAHZZ	5330-00-823-5366	761-5949-001	13499	GASKET		EA	1
5	98	PAHZZ	5905-00-681-5977	RN70C1212F	81349	RESISTOR, FIXED, FILM		EA	1
5	99	PAHZZ	5905-00-823-3479	RN70C2372F	81348	RESISTOR, FIXED, FILM		EA	2
5	100	PAHZZ	5905-00-811-4758	RN70C2872F	81349	RESISTOR, FIXED, FILM		EA	4
5	101	PAHZZ	5905-00-755-2346	RN70C8251F	81349	RESISTOR, FIXED, FILM		EA	2
5	102	XDHZZ		756-8885-001	13499	INSERT, JACK COV		EA	1
5	103	XDHZZ		756-8886-001	13499	SPRING, HELICAL, TORS		EA	1
5	104	PAHZZ	5315-00-297-0875	MS171444	96906	PIN, SPRING		EA	1
5	105	PAHZZ	5305-00-054-5638	MS51957-4	96906	SCREW, MACHINE		EA	2
5	106	XDHZZ		756-8889-001	13499	SPACER, PLATE		EA	1

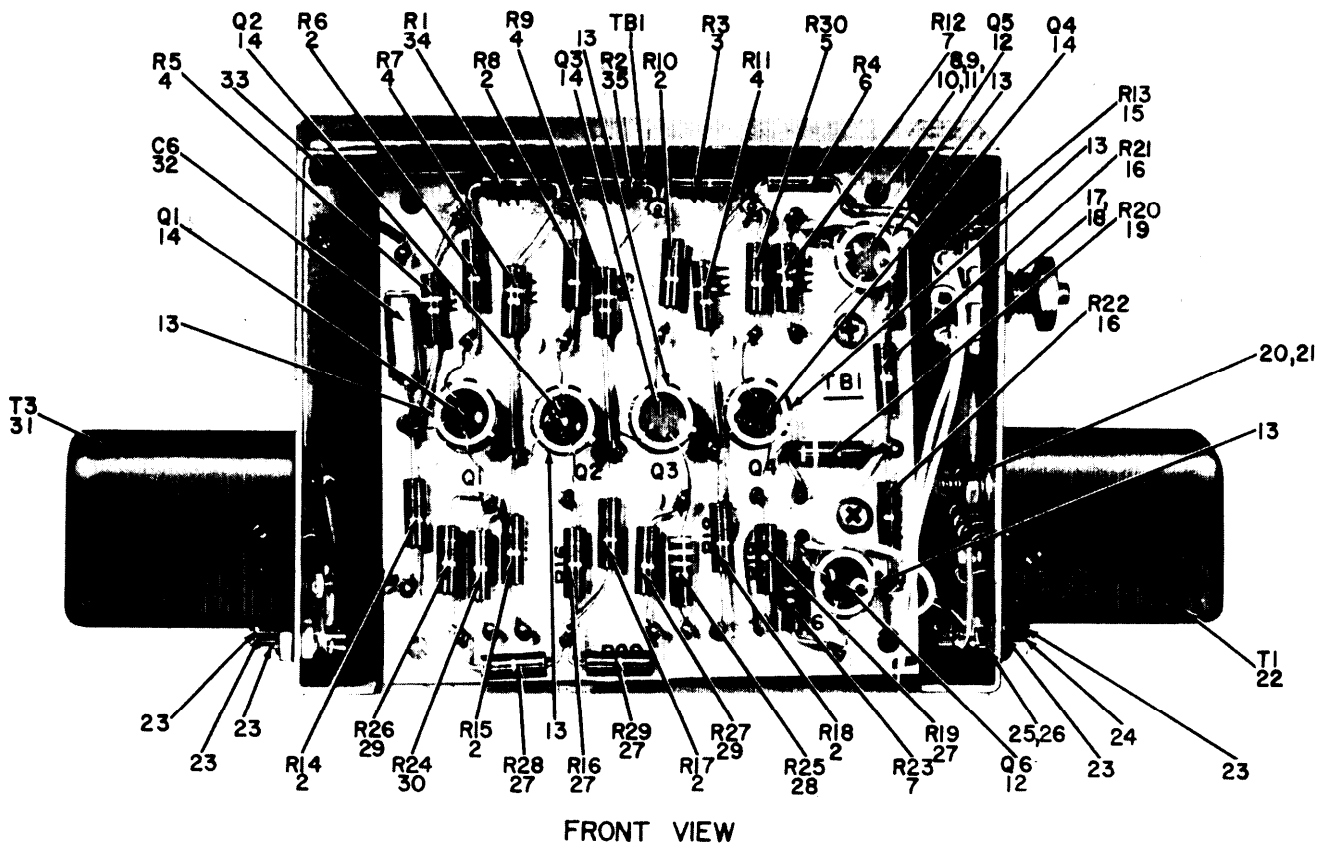

NOTE: FOR COMPLETE REFERENCE DESIGNATION PREFIX WITH AIAI OR AIAITBI.

EL4HK010

Figure 6. Amplifier Assembly, AF (761-7040-001) (Sheet 1 of 2).

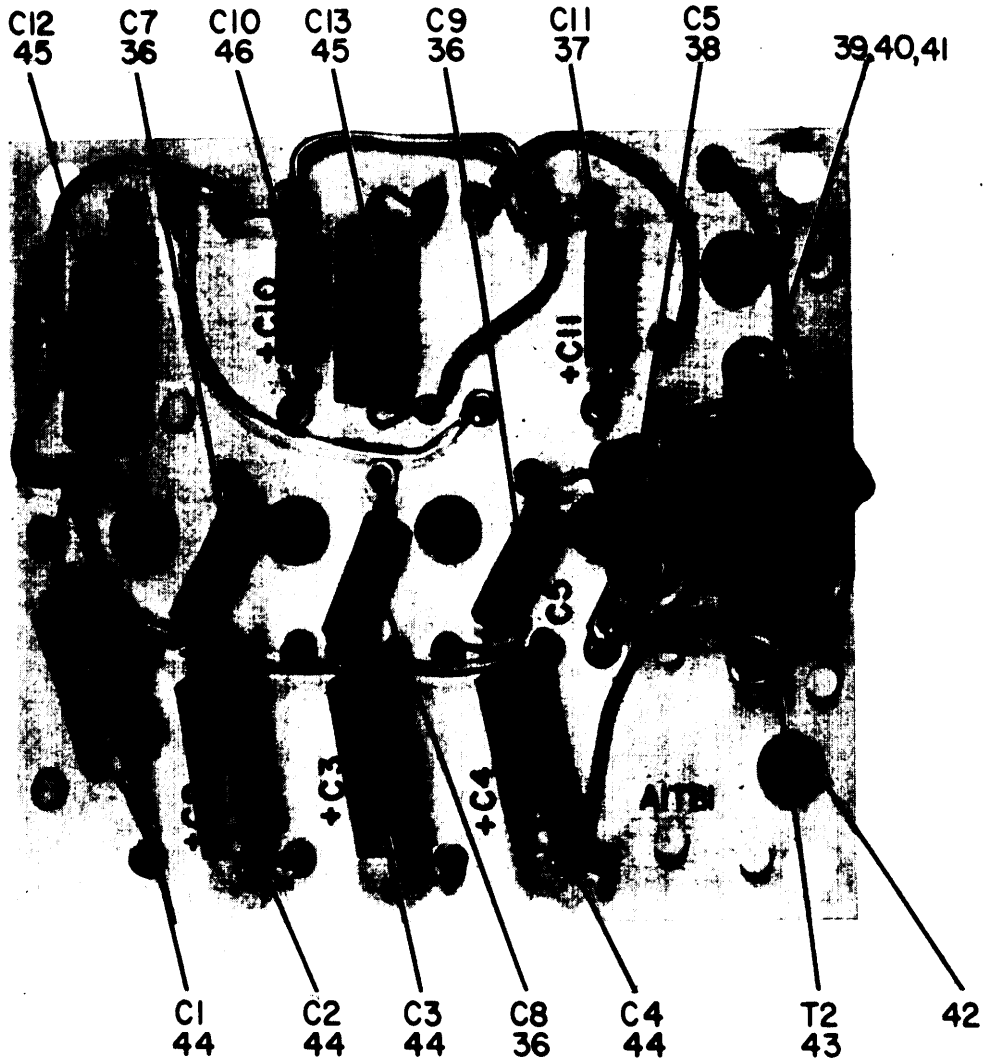

TBI REAR VIEW

**NOTE: FOR COMPLETE REFERENCE DESIGNATION
PREFIX WITH A1AITBI**

EL4HK011

Figure 6. Amplifier Assembly, AF (761-7040-001) (Sheet 2 of 2).

SECTION II

(1) ILLUSTRATION (A) FIG NO	(2) (B) ITEM NO	(3) SMR CODE	(4) NATIONAL STOCK NUMBER	(5) PART NUMBER	(6) DESCRIPTION FSCM	(7) USABLE ON CODE	(8) QTY INC IN UNIT
GROUP 0101 AMPLIFIER ASSEMBLY,AF (761-7040-001)							
6	1	XDHZZ		761-7039-001	13499 ELECTRONIC COMPONEN	EA	1
6	2	PAHZZ	5905-00-195-6453	RC20GF562J	81349 RESISTOR, FIXED, COMP	EA	6
6	3	PAHZZ	5905-00-195-6800	RC20GF561J	81349 RESISTOR, FIXED, COMP	EA	1
6	4	PAHZZ	5905-00-279-2616	RC20GF153J	81349 RESISTOR, FIXED, COMP	EA	4
6	5	PAHZZ	5905-00-195-6741	RC20GF272K	81349 RESISTOR, FIXED, COMP	EA	1
6	6	PAHZZ	5905-00-171-2006	RC20GF271J	81349 RESISTOR, FIXED, COMP	EA	1
6	7	PAHZZ	5905-00-279-3502	RC20GF123J	81349 RESISTOR, FIXED, COMP	EA	2
6	8	XDHZZ		756-9112-001	13499 NUT, SLEEVE	EA	4
6	9	PAHZZ	5305-00-054-5654	MS51957-20	96906 SCREW, MACHINE	EA	4
6	10	PAHZZ	5365-00-064-1922	541-5991-002	13499 SPACER, SLEEVE	EA	4
6	11	PAHZZ	5310-00-933-8118	MS35338-135	96906 WASHER, LOCK	EA	8
6	12	PAHZZ	5961-00-752-6081	JAN2N657	81349 TRANSISTOR	EA	2
6	13	PAHZZ	5999-00-904-3486	TXB2P032-037-3	98978 HEAT SINK, ELECTRICAL	EA	6
6	14	PAHZZ	5961-00-837-7262	MIL-S-19500/99	81349 TRANSISTOR	EA	4
6	15	PAHZZ	5905-00-644-9545	RV5LAYS253B	81349 RESISTOR, VARIABLE, N	EA	1
6	16	PAHZZ	5905-00-190-8883	RC20GF100J	81349 RESISTOR, FIXED, COMP	EA	2
6	17	XDHZZ		P334-0266-00	77250 NUT, PLAIN, HEXAGON	EA	1
6	18	XDHZZ		1714-05CADPL	78189 WASHER, LOCK	EA	1
6	19	PAHZZ	5905-00-111-4742	RC20GF391J	81349 RESISTOR, FIXED, COMP	EA	1
6	20	PAHZZ	5310-00-271-4642	MS35649-44	96906 WASHER	EA	4
6	21	PAHZZ	5310-00-782-1349	310-0045-00	79807 WASHER, FLAT	EA	4
6	22	PAHZZ	5950-00-906-6392	36677	73386 TRANSFORMER, AUDIO F	EA	1
6	23	XDHZZ		SL174-198	12615 TERMINAL, FEEDTHRU, T	EA	5
6	24	PAHZZ	5940-00-700-2971	AB406D	12615 TERMINAL, STUD	EA	1
6	25	PAHZZ	5310-00-934-9740	MS35649-225	96906 NUT, PLAIN, HEXAGON	EA	1
6	26	XDHZZ		310-0075-00	79807 WASHER, LOCK	EA	1
6	27	PAHZZ	5905-00-279-1880	RC20GF272J	81349 RESISTOR, FIXED, COMP	EA	4
6	28	PAHZZ	5905-00-279-3497	RC20GF393J	81349 RESISTOR, FIXED, COMP	EA	1
6	29	PAHZZ	5905-00-279-1897	RC20GF560J	81349 RESISTOR, FIXED, COMP	EA	2
6	30	PAHZZ	5905-00-141-0592	RC20GF122J	81349 RESISTOR, FIXED, COMP	EA	1
6	31	XDHZZ		A14667	70674 TRANSFORMER, AUDIO F	EA	1
6	32	PAHZZ	5910-00-904-3985	CS13BF685M	81349 CAPACITOR FIXED ELE	EA	1
6	33	XDHZZ		761-7029-004	13499 SCREW, MACHINE-M	EA	4
6	34	PAHZZ	5905-00-279-1876	RC20GF222J	81349 RESISTOR, FIXED, COMP	EA	1
6	35	PAHZZ	5905-00-195-6806	RC20GF102J	81349 RESISTOR, FIXED, COMP	EA	1
6	36	XDHZZ		CS13BD106M	81349 CAPACITOR, ELCTL	EA	3
6	37	PAHZZ	5910-00-904-5644	CS13BE156M	81349 CAPACITOR, FIXED, ELE	EA	1
6	38	PAHZZ	5910-00-043-1994	CM06F471J03	81349 CAPACITOR, FIXED, MTC	EA	1

SECTION II

(1)	(2)	(3)	(4)	(5)	(6)	(7)	(8)
ILLUSTRATION							
(A)	(B)	NATIONAL		DESCRIPTION		QTY	
FIG	ITEM	SMR	STOCK	PART			INC
NO	NO	CODE	NUMBER	NUMBER	FSCM	USABLE ON CODE	U/M
							UNIT
6	39	PAHZZ	5310-00-208-3786	P313-0132-00	77250	NUT, PLAIN, HEXAGON	EA 2
6	40	PAHZZ	5305-00-054-5646	MS51957-12	96906	SCREW, MACHINE	EA 2
6	41	PAHZZ	5310-00-933-8118	MS35338-135	96906	WASHER, LOCK	EA 2
6	42	XDHZZ		IMC302	10583	WASHER, FLAT	EA 6
6	43	XDHZZ		CR068	80223	TRANSFORMER, AUDIO F	EA 1
6	44	PAHZZ	5910-00-993-2201	CSR13E476KL	81349	CAPACITOR, ELCTL	EA 4
6	45	XDHZZ		CB13BC107M	81349	CAPACITOR, ELECTL	EA 2
6	46	XDHZZ		CS13BB476M	81349	CAPACITOR, ELCTL	EA 1

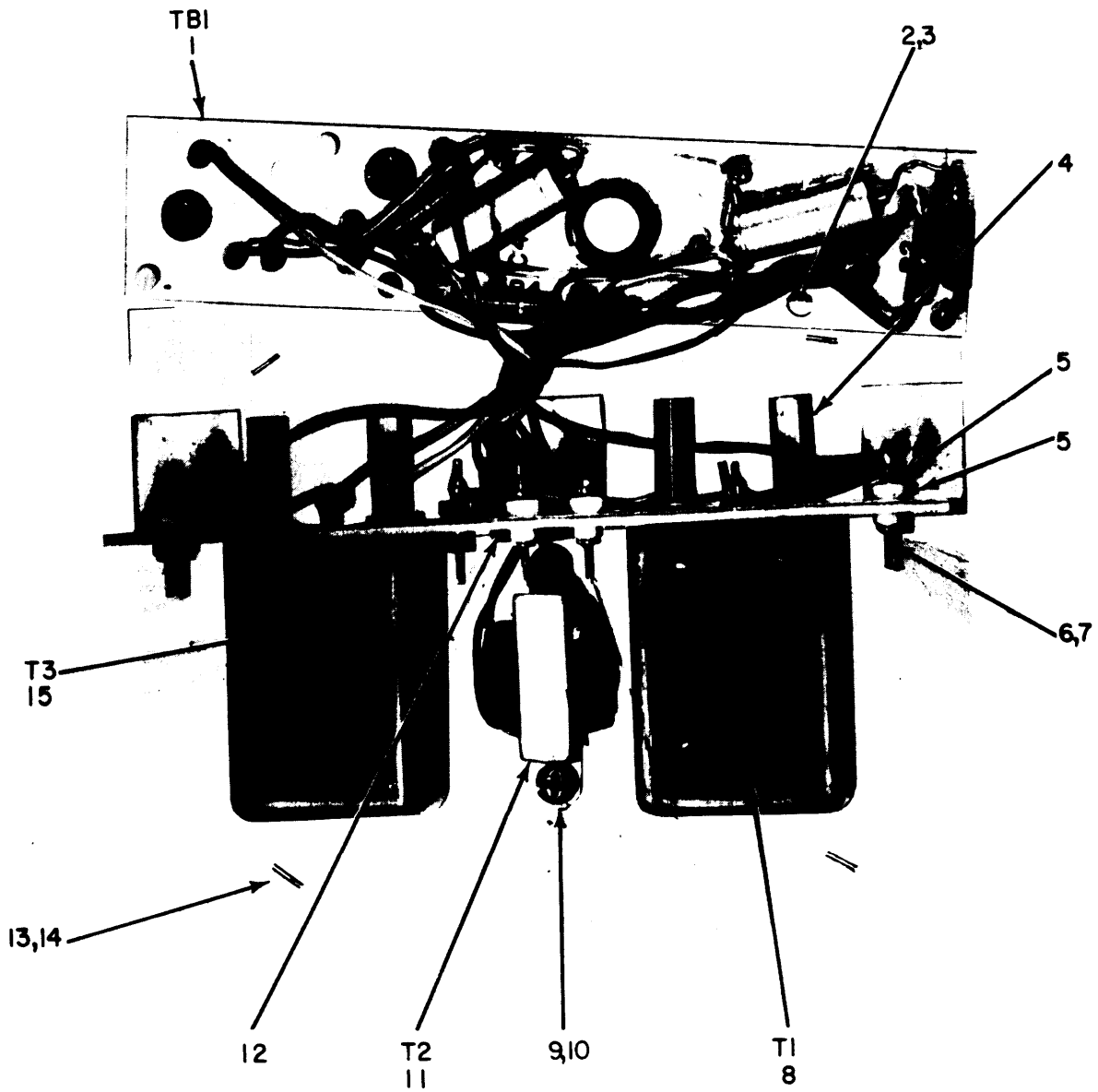

NOTE: FOR COMPLETE REFERENCE DESIGNATION PREFIX WITH AIA2

EL4HK012

Figure 7. Amplifier Assembly, AF (761-7041-001).

SECTION II

(1) ILLUSTRATION (A) FIG NO	(2) (B) ITEM NO	(3) SMR CODE	(4) NATIONAL STOCK NUMBER	(5) PART NUMBER	(6) FSCM	(7) DESCRIPTION USABLE ON CODE	(8) QTY INC IN UNIT
GROUP 0102 AMPLIFIER ASSEMBLY,AF							
(761-7041-001)							
7	1	XDHHH		761-7047-001	13499	AMPLIFIER SUBASSEMBLY	EA 1
7	2	PAHZZ	5305-00-054-5648	MS51957-14	96906	SCREW,MACHINE	EA 4
7	3	PAHZZ	5310-00-933-8118	MS35338-135	96906	WASHER,LOCK	EA 8
7	4	PAHZZ	5310-00-053-1551	540-9041-003	13499	NUT,PLAIN,HEXAGON	EA 4
7	5	PAHZZ	5940-00-700-2971	AB406D	12615	TERMINAL,STUD	EA 2
7	6	PAHZZ	5310-00-934-9740	MS35649-225	96906	NUT,PLAIN,HEXAGON	EA 2
7	7	PAHZZ	5310-00-981-2255	310-0074-00	79807	WASHER,LOCK	EA 2
7	8	XDHZZ		37346	73386	TRANSFORMER,AUDIO F	EA 1
7	9	PAHZZ	5310-00-208-3786	P313-0132-00	77250	NUT,PLAIN,HEXAGON	EA 2
7	10	PAHZZ	5305-00-054-5647	MS51957-13	96906	SCREW,MACHINE	EA 2
7	11	XDHZZ		CR068	80223	TRANSFORMER,AUDIO F	EA 1
7	12	PAHZZ	5325-00-174-5317	MS35489-4	96906	GROMMET,RUBBER	EA 1
7	13	PAHZZ	5305-00-054-5647	MS51957-13	96906	SCREW,MACHINE	EA 10
7	14	PAHZZ	5310-00-933-8118	MS35338-135	96906	WASHER,LOCK	EA 15
7	15	PAHZZ	5950-00-999-7267	A14666	70674	TRANSFORMER,AUDIO F	EA 1

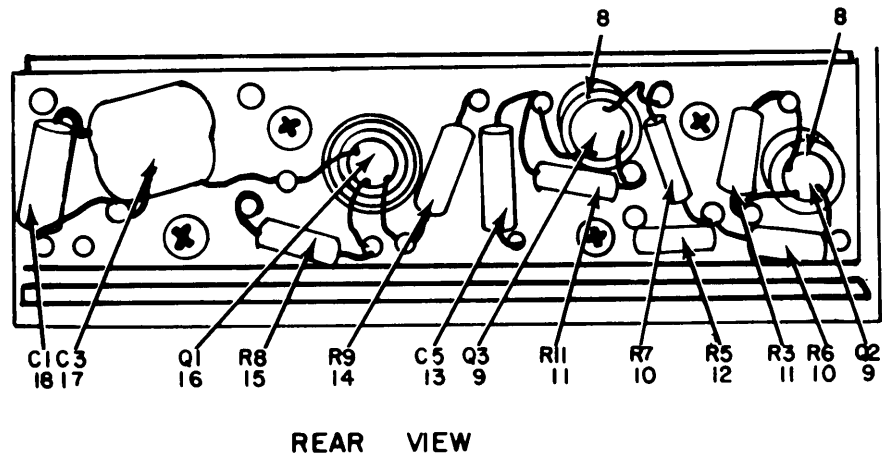
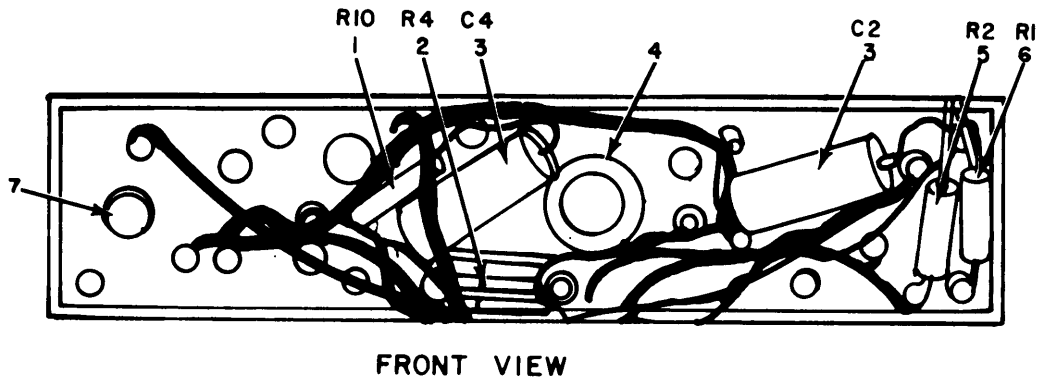

NOTE FOR COMPLETE REFERENCE DESIGNATION PREFIX WITH A1A2TBI.

EL4HK013

Figure 8. Amplifier Subassembly (761-7047-001).

SECTION II

(1) ILLUSTRATION (A) FIG NO	(2) (B) ITEM NO	(3) SMR CODE	(4) NATIONAL STOCK NUMBER	(5) PART NUMBER	(6) DESCRIPTION FSCM	(7) USABLE ON CODE	(8) QTY INC IN UNIT
GROUP 010201 AMPLIFIER SUBASSEMBLY							
(761-7047-001)							
8	1	PAHZZ	5905-00-279-1880	RC20GF272J	81349 RESISTOR, FIXED, COMP	EA	1
8	2	PAHZZ	5905-00-279-1751	RC20GF302J	81349 RESISTOR, FIXED, COMP	EA	1
8	3	PAHZZ	5910-00-993-2201	CSR13E476KL	81349 CAPACITOR, ELCTL	EA	2
8	4	XDHZZ		T1571	98291 RETAINER, TRANSISTOR	EA	1
8	5	PAHZZ	5905-00-279-1876	RC20GF222J	81349 RESISTOR, FIXED, COMP	EA	1
8	6	PAHZZ	5905-00-279-2616	RC20GF153J	81349 RESISTOR, FIXED, COMP	EA	1
8	7	XDHZZ		IMC302	10583 WASHER, FLAT	EA	2
8	8	PAHZZ	5999-00-904-3486	TXB2P032-037-3	98978 HEAT SINK, ELECTRICAL	EA	2
8	9	PAHZZ	5961-00-080-8752	MIL-S-19500/74	81349 TRANSISTOR	EA	2
8	10	PAHZZ	5905-00-190-8883	RC20GF100J	81349 RESISTOR, FIXED, COMP	EA	2
8	11	PAHZZ	5905-00-279-3502	RC20GF123J	81349 RESISTOR, FIXED, COMP	EA	2
8	12	PAHZZ	5905-00-192-3973	RC20GF471J	81349 RESISTOR, FIXED, COMP	EA	1
8	13	XDHZZ		CS13BD106M	81349 CAPACITOR, ELCTL	EA	1
8	14	PAHZZ	5905-00-192-3971	RC20GF331J	81349 RESISTOR, FIXED, COMP	EA	1
8	15	PAHZZ	5905-00-195-6453	RC20GF562J	81349 RESISTOR, FIXED, COMP	EA	1
8	16	PAHZZ	5961-00-837-7262	MIL-S-19500/99	81349 TRANSISTOR	EA	1
8	17	PAHZZ	5910-00-060-1194	CM06F102J03	81349 CAPACITOR, FIXED, MIC	EA	1
8	18	PAHZZ	5910-00-904-3985	CS13BF685M	81349 CAPACITOR FIXED ELE	EA	1

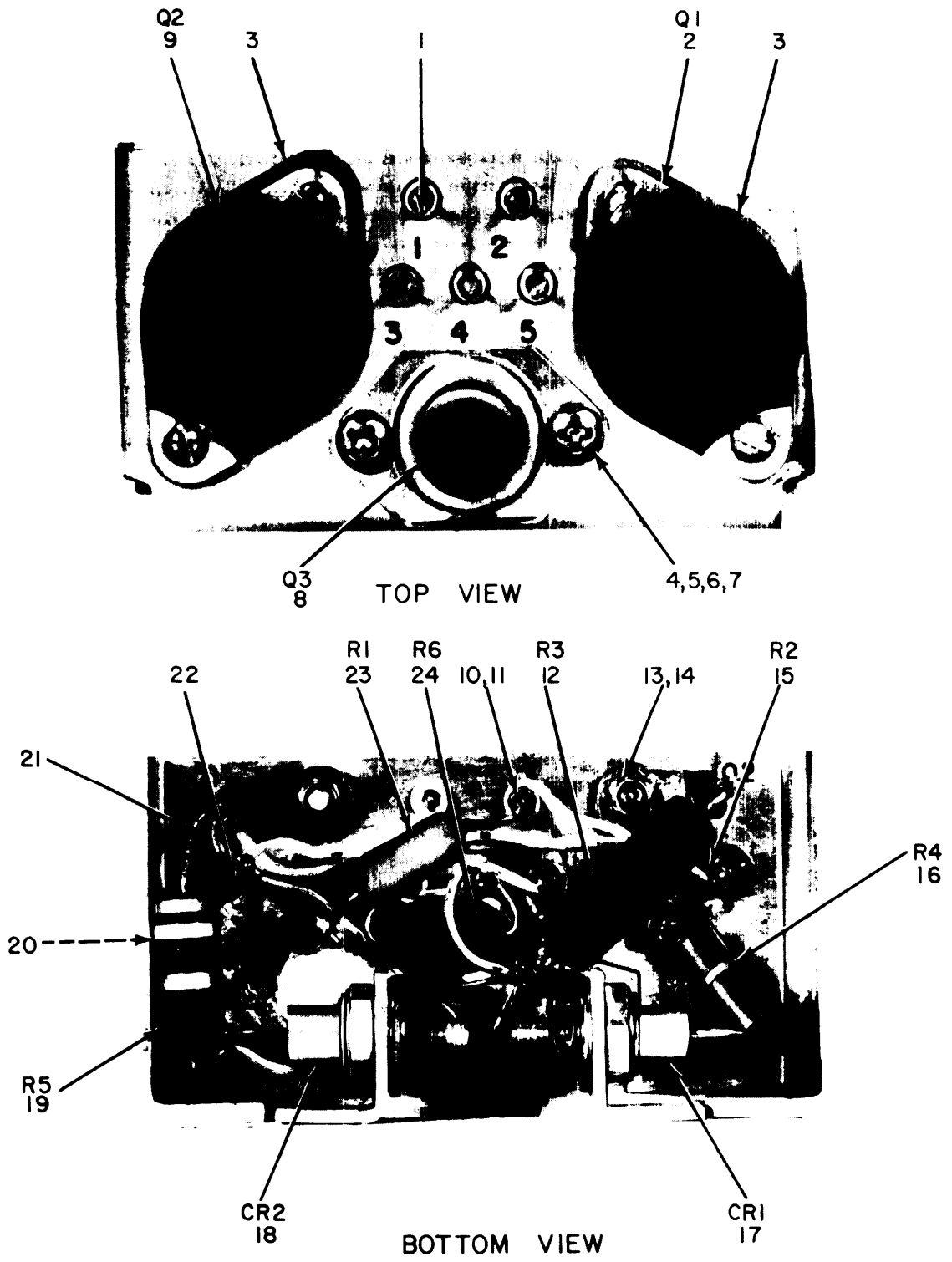

NOTE: FOR COMPLETE REFERENCE DESIGNATION PREFIX WITH AIA4

EL4HK014

Figure 9. Transient Blanking Assembly.

SECTION II

(1) ILLUSTRATION (A) FIG NO	(2) (B) ITEM NO	(3) SMR CODE	(4) NATIONAL STOCK NUMBER	(5) PART NUMBER	(6) FSCM	(7) DESCRIPTION	(8) QTY INC IN UNIT
USABLE ON CODE U/M							
GROUP 0103 TRANSIENT BLANKING ASSEMBLY							
9	1	PAHZZ	5940-00-700-2971	AB406D	12615	TERMINAL, STUD	EA 1
9	2	PAHZZ	5961-00-954-2159	2N1165	81349	TRANSISTOR	EA 1
9	3	PAHZZ	5999-00-441-1688	7274775	16758	MOUNTING PAD, ELECTR	EA 2
9	4	PAHZZ	5310-00-934-9761	MS35649-264	96906	NUT, PLAIN, HEXAG	EA 2
9	5	PAHZZ	5305-00-054-6652	MS51957-28	96906	SCREW, MACHINE	EA 2
9	6	PAHZZ	5310-00-515-8243	310-0046-00	79807	WASHER, FLAT	EA 2
9	7	PAHZZ	5310-00-184-8996	310009500	70117	WASHER, LOCK	EA 4
9	8	PAHZZ	5961-00-836-0377	2N1485	80131	TRANSISTOR	EA 1
9	9	PAHZZ	5961-00-999-5134	2N3026	04713	TRANSISTOR	EA 1
9	10	PAHZZ	5310-00-934-9740	MS35649-225	96906	NUT, PLAIN, HEXAGON	EA 1
9	11	PAHZZ	5310-00-981-2255	310-0074-00	79807	WASHER, LOCK	EA 1
9	12	XDHZZ		RW67VL51	81349	RESISTOR, FXD, WW	EA 1
9	13	PAHZZ	5310-00-614-3500	68-1660-40	72962	NUT, SELF-LOCKING, HE	EA 2
9	14	PAHZZ	5310-00-591-3416	310-0054-00	79807	WASHER, FLAT	EA 4
9	15	PAHZZ	5905-00-279-2658	RC20GF820K	81349	RESISTOR, FIXED, COMP	EA 1
9	16	PAHZZ	5905-00-110-0991	RC32GF151K	81349	RESISTOR, FIXED, COMP	EA 1
9	17	PAHZZ	5961-00-850-9564	JAN1N2990B	81349	SEMICONDUCTOR, D	EA 1
9	18	PAHZZ	5961-00-850-9440	1N2984B	81349	SEMICONDUCTOR DEVIC	EA 1
9	19	PAHZZ	5905-00-156-0435	RC42GF390K	81349	RESISTOR, FIXED, COMP	EA 1
9	20	PAHZZ	5305-00-054-5648	MS51957-14	96906	SCREW, MACHINE	EA 3
9	21	XDHZZ		756-9136-001	13499	PLATE, SILKSCREE	EA 1
9	22	XDHZZ		SL174-198	12615	TERMINAL, FEEDTHRU, I	EA 4
9	23	PAHZZ	5905-00-045-5422	RW59VR10	81349	RESISTOR, FIXED, WIRE	EA 1
9	24	PAHZZ	5905-00-990-2912	RW69V2R7	81349	RESISTOR, FIXED, WIRE	EA 1

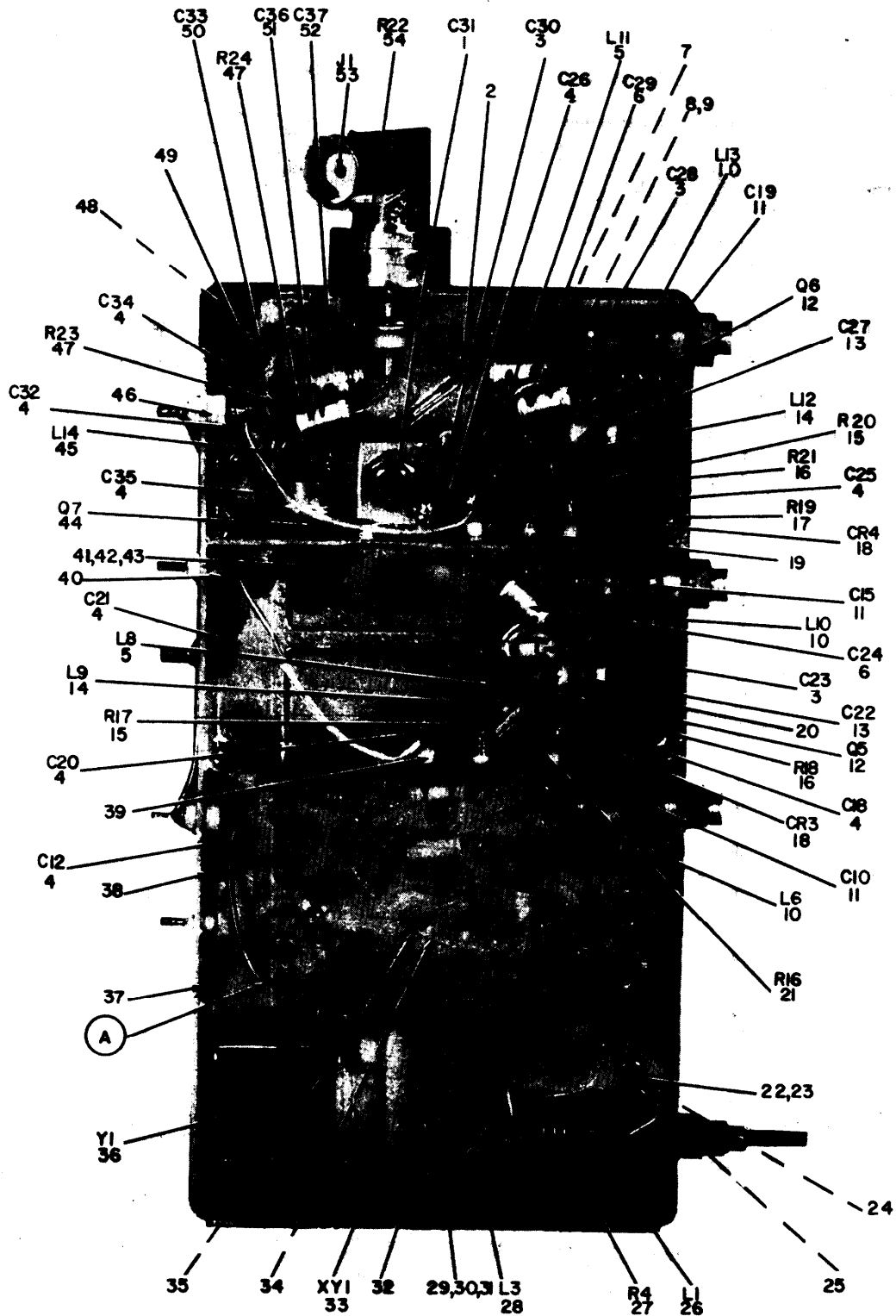

NOTE FOR COMPLETE REFERENCE DESIGNATION
 PREFIX WITH AIA5

EL4411015

Figure 10. Test Generator, UHF (MK-731A/ARC-51X) (Sheet 1 of 2).

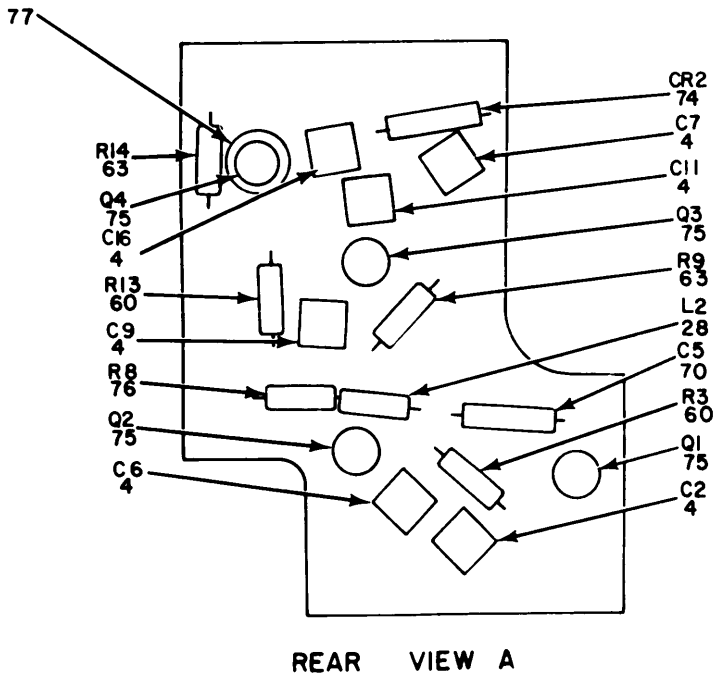
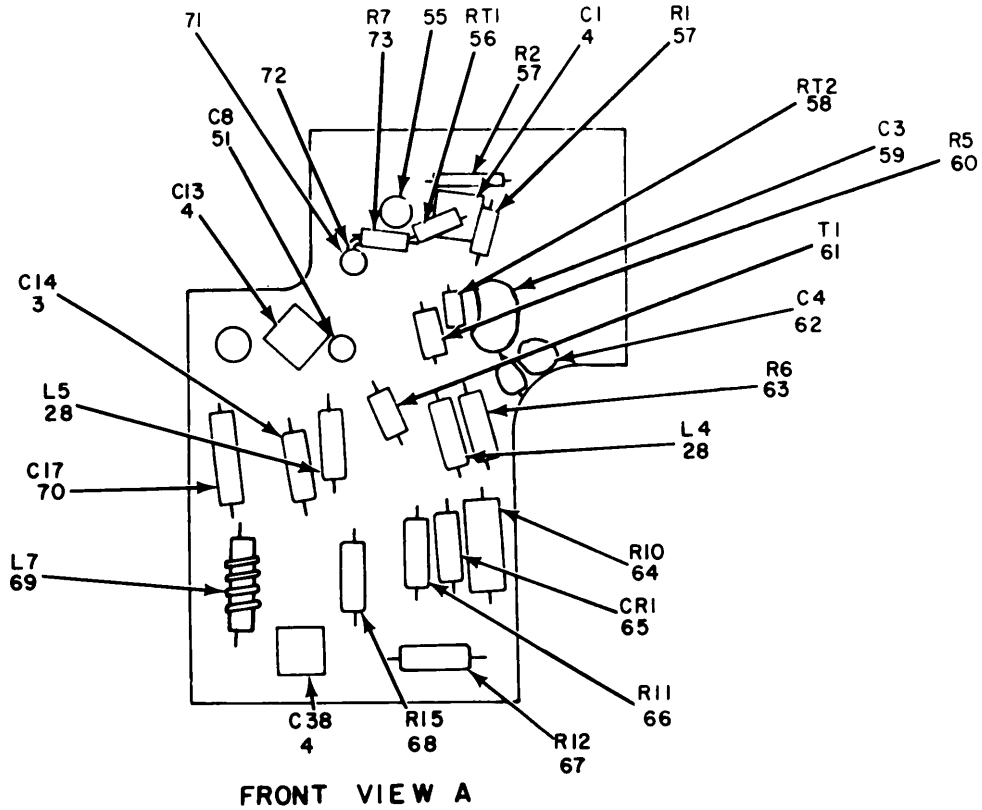

NOTE: FOR COMPLETE REFERENCE DESIGNATION
PREFIX WITH AIA5A2

EL4HK016

Figure 10. Test Generator, UHF (MK-731A/ARC-51X) (Sheet 2 of 2).

SECTION II

(1) ILLUSTRATION (A) FIG NO	(2) ITEM (B) NO	(3) SMR CODE	(4) NATIONAL STOCK NUMBER	(5) PART NUMBER	(6) DESCRIPTION FSCM	(7) USABLE ON CODE	(8) QTY INC IN UNIT
GROUP 0104 TEST GENERATOR, UHF							
10	1	PAHZZ	5910-00-869-4840	VC951	73899 CAPACITOR, VARIABLE	2CG	EA 1
10	2	XDHZZ		1P4-26A	86577 TERMINAL, STUD	2CG	EA 5
10	3	XDHZZ		374NP0125DEGC5PF PF	72982 CAPACITOR, FXD, C	2CG	EA 4
10	4	PAHZZ	5910-00-890-8988	CK05CW102M	81349 CAPACITOR, FIXED, CER	2CG	EA 18
10	5	PAHZZ	1270-00-612-4041	F1913-101	72656 PARASITIC SUPPR	2CG	EA 2
10	6	XDHZZ		374NP0125DEGC4PF FORM25PF	72982 CAPACITOR, FXD, C	2CG	EA 2
10	7	XDHZZ		767-7540-001	13499 HEAT SINK, ELEC	2CG	EA 2
10	8	PAHZZ	5310-00-938-2013	MS35649-24	96906 NUT, PLAIN, HEXAGON	2CG	EA 3
10	9	PAHZZ	5310-00-316-9040	310-0053-00	79807 WASHER, FLAT	2CG	EA 2
10	10	XDHZZ		775-2748-001	13499 COIL, RADIO FREQUENC	2CG	EA 3
10	11	PAHZZ	5910-00-781-3239	VC20GY	73899 CAPACITOR, VARIABLE	2CG	EA 3
10	12	PAHZZ	5961-00-954-4864	2N3866	07688 TRANSISTOR	2CG	EA 2
10	13	XDHZZ		2482-00W5R0501M	72982 CAPACITOR, FXD, C	2CG	EA 2
10	14	PAHZZ	5950-00-059-5921	1025-08	99800 COIL, RADIO FREQUENC	2CG	EA 2
10	15	PAHZZ	5905-00-686-4528	RC07GF332K	81349 RESISTOR, FIXED, COMP	2CG	EA 2
10	16	PAHZZ	5905-00-465-9557	RC07GF100K	81349 RESISTOR, FIXED, COMP	2CG	EA 2
10	17	PAHZZ	5905-00-104-8363	RC07GF820K	81349 RESISTOR, FIXED, COMP	2CG	EA 1
10	18	PAHZZ	5961-00-577-6084	1N645	81349 SEMICONDUCTOR DEVIC	2CG	EA 2
10	19	PAHZZ	5940-00-723-2876	SL180-231	12615 TERMINAL, FEEDTHRU, I	2CG	EA 2
10	20	PAHZZ	5310-00-050-6833	F22NCFMA1-40	72962 NUT, SLFLKG, CLIN	2CG	EA 10
10	21	PAHZZ	5905-00-755-0797	RC07GF560K	81349 RESISTOR, FIXED, COMP	2CG	EA 1
10	22	XDHZZ		310-0075-00	79807 WASHER, LOCK	2CG	EA 14
10	23	PAHZZ	5305-00-054-5636	MS51957-2	96906 SCREW, MACHINE	2CG	EA 4
10	24	PAHZZ	5305-00-685-7072	P330-2284-00	77250 SCREW, MACHINE	2CG	EA 7
10	25	XDHZZ		540-9003-003	13499 POST, ELECTRICAL-MEC	2CG	EA 4
10	26	XDHZZ		756-8791-001	13499 COIL, RADIO FREQUENC	2CG	EA 1
10	27	PAHZZ	5905-00-752-3335	RC07GF122K	81349 RESISTOR, FIXED, COMP	2CG	EA 1
10	28	PAHZZ	5950-00-892-8301	1025-12	99800 COIL, RADIO FREQUENC	2CG	EA 4
10	29	XDHZZ		302-0622-000	05284 WASHER, INSULATOR	2CG	EA 1
10	30	PAHZZ	5310-00-622-1724	68-1660-26	72962 NUT, SELF-LOCKING, HE	2CG	EA 1
10	31	PAHZZ	5305-00-054-5639	MS51957-5	96906 SCREW, MACHINE	2CG	EA 1
10	32	XDHZZ		775-2754-001	13499 SPACER, MAINTENANCE	2CG	EA 1
10	33	PAHZZ	5935-00-581-6941	TS0205C01	81349 SOCKET, PLUG-IN ELEC	2CG	EA 1
10	34	PAHZZ	5940-00-007-5277	4040-2HDSPL	77147 TERMINAL, LUG	2CG	EA 1
10	35	XDHZZ		AB397-1A	12615 TERMINAL, STUD	2CG	EA 1
10	36	PAHZZ	5955-00-738-6145	M9-6884-00	13855 CRYSTAL UNIT, QU	2CG	EA 1
10	37	PAHZZ	5305-00-054-6651	MS51957-27	96906 SCREW, MACHINE	2CG	EA 3
10	38	PAHZZ	5940-00-904-9633	SL179-230	12615 TERMINAL, STUD	2CG	EA 1

SECTION II

(1) ILLUSTRATION (A) FIG NO	(2) ITEM NO	(3) SMR CODE	(4) NATIONAL STOCK NUMBER	(5) PART NUMBER	(6) DESCRIPTION FSCM	(7) USABLE ON	(8) QTY INC IN UNIT
10	39	PAHZZ	5940-00-950-5760	SL441-434DWHT	12615 TERMINAL,STUD	2CG	EA 15
10	40	PAHZZ	5940-00-877-8430	TF300	98291 TERMIANL,FEEDTHRU,I	2CG	EA 1
10	41	PAHZZ	5310-00-270-8810	MS35650-104	96906 WASHER	2CG	EA 1
10	42	PAHZZ	5310-00-685-1450	310-0049-000	79807 WASHER,FLAT	2CG	EA 1
10	43	PAHZZ	5310-00-543-5933	MS35333-73	96906 WASHER,LOCK	2CG	EA 1
10	44	PAHZZ	5961-00-586-5131	2N3375	80131 TRANSISTOR	2CG	EA 1
10	45	XDHZZ		775-2747-001	13499 COIL,RADIO FREQUENC	2CG	EA 1
10	46	XDHZZ		SL158-198	12615 TERMINAL,FEEDTHRU,I	2CG	EA 3
10	47	PAHZZ	5905-00-889-0201	RC07GF2R7J	81349 RESISTOR,FIXED,COMP	2CG	EA 2
10	48	PAHZZ	5305-00-054-5646	MS51957-12	96906 SCREW,MACHINE	2CG	EA 6
10	49	PAHZZ	5940-00-702-3517	AB396-1	12615 TERMINAL,STUD	2CG	EA 2
10	50	PAHZZ	5910-00-022-2760	CK06BX104K	81349 CAPACITOR,FXD,C	2CG	EA 1
10	51	PAHZZ	5910-00-489-7610	374NP0125-DEGC10P FFORM1-OPF	72982 CAPACITOR,FXD,C	2CG	EA 2
10	52	PAHZZ	5910-00-702-3768	CC20CH070D	81349 CAPACITOR,FIXED,CER	2CG	EA 1
10	53	PAHZZ	5935-00-199-1790	UG109BU	80058 ADAPTER,CONNECTOR	2CG	EA 1
10	54	PAHZZ	5905-00-050-7383	BWHIROJ	75042 RESISTOR,FIXED,WIRE	2CG	EA 1
10	55	PAHZZ	5940-00-950-5761	SL354-351DWHT	12615 TERMINAL,FEEDTH	2CG	EA 14
10	56	PAHZZ	5905-00-880-0437	997F41	10646 RESISTOR,THERMAL	2CG	EA 1
10	57	PAHZZ	5905-00-816-8554	RC07GF103K	81349 RESISTOR,FIXED,COMP	2CG	EA 2
10	58	PAHZZ	5905-00-755-2571	997F18	10646 RESISTOR,THRMAL	2CG	EA 1
10	59	PAHZZ	5910-00-063-8428	DM10-200J	72136 CAPACITOR,FXD,M	2CG	EA 1
10	60	PAHZZ	5905-00-726-6433	RC07GF222K	81349 RESISTOR,FIXED,COMP	2CG	EA 3
10	61	PAHZZ	5950-00-043-4837	767-7558-001	13499 TRANSFORMER,RADIO F	2CG	EA 1
10	62	PAHZZ	5910-00-089-7504	DM10F100J05004CR	72136 CAPACITOR,FXD,M	2CG	EA 1
10	63	PAHZZ	5905-00-687-0000	RC07GF183J	81349 RESISTOR,FIXED,COMP	2CG	EA 3
10	64	PAHZZ	5905-00-111-8357	RC20GF681K	81349 RESISTOR,FIXED,COMP	2CG	EA 1
10	65	PAHZZ	5961-00-892-1009	1N963B	81349 SEMICONDUCTOR DEVIC	2CG	EA 1
10	66	PAHZZ	5905-00-120-9154	RC07GF471J	81349 RESISTOR,FIXED,COMP	2CG	EA 1
10	67	PAHZZ	5905-00-726-5346	RC07GF182K	81349 RESISTOR,FIXED,COMP	2CG	EA 1
10	68	PAHZZ	5950-00-683-7721	RC07GF101J	81349 RESISTOR,FIXED,COMP	2CG	EA 1
10	69	XDHZZ		775-2750-001	13499 SUPPRESSOR,PARASITI	2CG	EA 1
10	70	XDHZZ		374NP1025DEGC4PF FORM25PF	72982 CAPACITOR,FXD,C	2CG	EA 2
10	71	XDHZZ		306-0983-000	86577 TERMINAL,STUD	2CG	EA 2
10	72	PAHZZ	5940-00-914-9911	SS5170	86577 TERMIANL,STUD	2CG	EA 2
10	73	PAHZZ	5905-00-825-2360	RC07GF221K	81349 RESISTOR,FIXED,COMP	2CG	EA 1
10	74	PAHZZ	5961-00-847-5244	1N973B	81349 SEMICONDUCTOR DEVIC	2CG	EA 1
10	75	PAHZZ	5961-00-905-4815	2N918	81349 TRANSISTOR	2CG	EA 4
10	76	PAHZZ	5905-00-752-3338	RC07GF102K	81349 RESISTOR,FIXED,COMP	2CG	EA 1
10	77	PAHZZ	5961-00-732-5028	T1533	98291 RETAINER,TRANSISTOR	2CG	EA 4

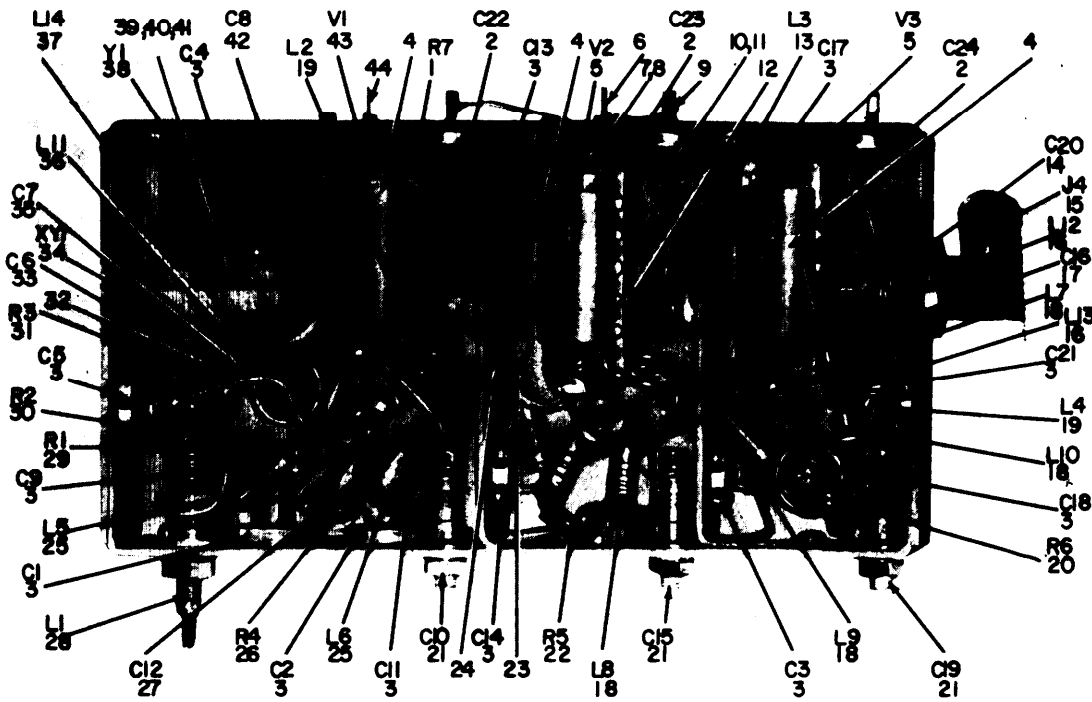

NOTE: FOR COMPLETE REFERENCE DESIGNATION PREFIX WITH AIA5.

EL4HK017

Figure 11. Test Generator, UHF (MK-731/ARC-51X).

SECTION II

(1) ILLUSTRATION (A) FIG NO	(2) (B) ITEM NO	(3) SMR CODE	(4) NATIONAL STOCK NUMBER	(5) PART NUMBER	(6) FSCM	(7) DESCRIPTION	(8) USABLE ON CODE	(9) U/M	(10) QTY INC IN UNIT
11	1	PAHZZ	5905-00-279-3506	RC20GF332J	81349	RESISTOR, FIXED, COMP	2BH	EA	1
11	2	XDHZZ		M23-1000M	83021	CAPACITOR, FXD, M	2BH	EA	3
11	3	PAHZZ	5910-00-276-6901	652025-0644102M		CAPACITOR, FXD, M	2BH	EA	12
					72982				
11	4	PAHZZ	5960-00-636-0183	T3-491	98978	RETAINER, ELECTRON T	2BH	EA	3
11	5	XDHZZ		8185	94991	ELECTRON TUBE	2BH	EA	2
11	6	XDHZZ		AB396-2A	12615	TERMINAL, STUD	2BH	EA	3
11	7	PAHZZ	5305-00-764-2966	MS51959-2	96906	SCREW, MACHINE	2BH	EA	3
11	8	PAHZZ	5310-00-981-2255	310-0074-00	79807	WASHER, LOCK	2BH	EA	4
11	9	PAHZZ	5940-00-916-2776	SL314-231	12615	TERMINAL FEEDTHRU	2BH	EA	3
11	10	PAHZZ	5305-00-054-5646	MS51957-12	96906	SCREW, MACHINE	2BH	EA	6
11	11	PAHZZ	5310-00-050-6833	F22NCFMA1-40	72962	NUT, SLFLKG, CLAM	2BH	EA	10
11	12	PAHZZ	5960-00-819-3926	T3-361	98978	SHIELD, ELECTRON TUB	2BH	EA	3
11	13	XDHZZ		756-8792-002	13499	COIL, RF	2BH	EA	1
11	14	PAHZZ	5910-00-043-1994	CM06F471J03	81349	CAPACITOR, FIXED, MIC	2BH	EA	1
11	15	PAHZZ	5935-00-199-1790	UG109BU	80058	ADAPTER, CONNECTOR	2BH	EA	1
11	16	PAHZZ	5950-00-764-4034	MS18130-3	96906	COIL, RADIO FREQUENC	2BH	EA	2
11	17	PAHZZ	5910-00-726-2448	CC20CH050D	81349	CAPACITOR, FIXED, CER	2BH	EA	1
11	18	PAHZZ	5950-00-764-9764	MS18130-6	96906	COIL, RADIO FREQUENC	2BH	EA	4
11	19	PAHZZ	5950-00-906-6390	756-8792-001	13499	COIL, RADIO FREQUENC	2BH	EA	2
11	20	PAHZZ	5905-00-141-1149	RC32GF391K	81349	RESISTOR, FIXED, COMP	2BH	EA	1
11	21	PAHZZ	5910-00-781-3239	VC20GY	73899	CAPACITOR, VARIABLE	2BH	EA	3
11	22	PAHZZ	5905-00-825-2360	RC07GF221K	81349	RESISTOR, FIXED, COMP	2BH	EA	1
11	23	XDHZZ		AB397-1A	12615	TERMINAL, STUD	2BH	EA	1
11	24	PAHZZ	5310-00-934-9740	MS35649-225	96906	NUT, PLAIN, HEXAGON	2BH	EA	1
11	25	PAHZZ	5950-00-764-3186	MS18130-2	96906	COIL, R	2BH	EA	2
11	26	PAHZZ	5905-00-752-3338	RC07GF102K	81349	RESISTOR, FIXED, COMP	2BH	EA	1
11	27	PAHZZ	5910-00-617-4948	CC20CK010D	81349	CAPACITOR, FIXED, CER	2BH	EA	1
11	28	XDHZZ		756-8791-001	13499	COIL, RADIO FREQUENC	2BH	EA	1
11	29	PAHZZ	5905-00-688-4447	RC07GF473K	81349	RESISTOR, FIXED, COMP	2BH	EA	1
11	30	PAHZZ	5905-00-683-7721	RC07GF101J	81349	RESISTOR, FIXED, COMP	2BH	EA	1
11	31	PAHZZ	5905-00-682-4105	RC07GF224J	81349	RESISTOR, FIXED, COMP	2BH	EA	1
11	32	PAHZZ	5940-00-552-4531	47254-68	80020	TERMINAL, LUG	2BH	EA	1
11	33	PAHZZ	5910-00-067-7293	CM05C050K03	81349	CAPACITOR, FIXED, MIC	2BH	EA	1
11	34	PAHZZ	5935-00-581-6941	TS0205C01	81349	SOCKET, PLUG-IN ELEC	2BH	EA	1
11	35	PAHZZ	5910-00-763-4038	CM05ED360G03	81349	CAPACITOR, FXD, M	2BH	EA	1
11	36	PAHZZ	5950-00-734-3940	MS18130-8	96906	COIL, RADIO FREQUENC	2BH	EA	1
11	37	PAHZZ	5950-00-764-3188	MS18130-4	96906	COIL, RADIO FREQUENC	2BH	EA	1
11	38	PAHZZ	5955-00-738-6145	M9-6884-00	13855	CRYSTAL UNIT QU	2BH	EA	1
11	39	XDHZZ		302-0622-000	05284	WASHER, INSULATO	2BH	EA	1

SECTION II

(1)	(2)	(3)	(4)	(5)	(6)	(7)	(8)	
ILLUSTRATION							QTY	
(A)	(B)	NATIONAL			DESCRIPTION		INC	
FIG	ITEM	SMR	STOCK	PART			IN	
NO	NO	CODE	NUMBER	NUMBER	FSCM	USABLE ON CODE	U/M	
							UNIT	
11	40	PAHZZ	5310-00-268-6116	P313-0156-00	77250	NUT, PLAIN, HEXAGON	28H	EA 1
11	41	PAHZZ	5305-00-207-7465	P343-0287-00	77250	SCREW, MACHINE	28H	EA 1
11	42	XDHZZ		CC20RJ030D	81349	CAPACITOR, FXD, C	28H	EA 1
11	43	PAHZZ	5960-00-855-2102	6111WA	81349	ELECTRON TUBE	28H	EA 1
11	44	PAHZZ	5940-00-904-6646	SL283-230	12615	TERMIANL, STUD	28H	EA 14

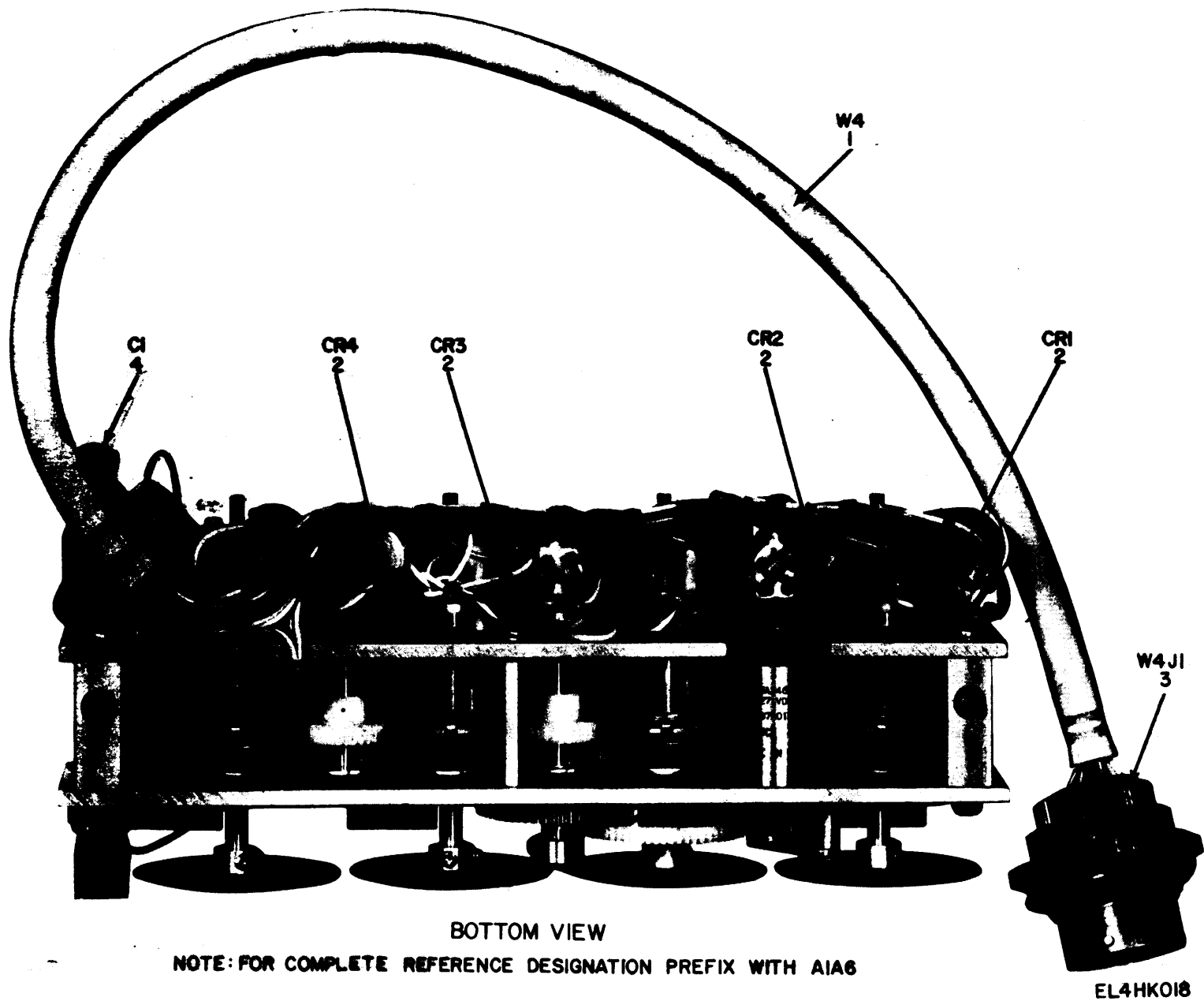

BOTTOM VIEW

NOTE: FOR COMPLETE REFERENCE DESIGNATION PREFIX WITH AIA6

Figure 12. Readout Assembly (Sheet 1 of 2).

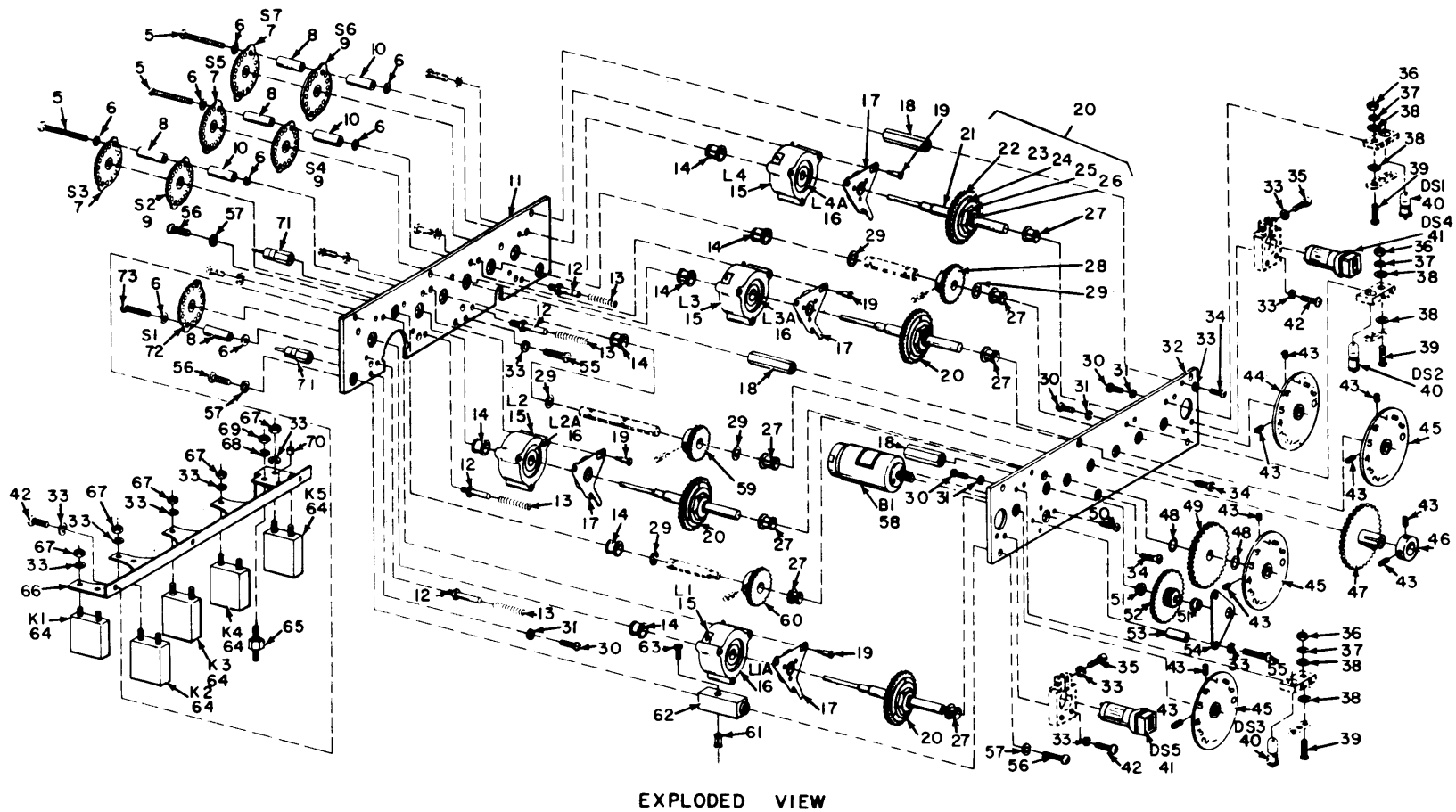

NOTE: FOR COMPLETE REFERENCE DESIGNATION
PREFIX WITH A1A6.

EL 4HK019

Figure 12. Readout Assembly (Sheet 2 of 2).

SECTION II

(1) ILLUSTRATION (A) FIG NO	(2) ITEM NO	(3) SMR CODE	(4) NATIONAL STOCK NUMBER	(5) PART NUMBER	(6) DESCRIPTION FSCM	(7) USABLE ON CODE U/M	(8) QTY INC IN UNIT
12	1	XDHHH		761-7060-001	13499 WIRING HARNESS	EA	1
12	2	PAHZZ	5961-00-577-6214	JAN1N538	81350 SEMICONDUCTOR DEVIC	EA	4
12	3	PAHZZ	5935-00-951-9331	MS3114E16-26PW	96906 CONNECTOR, RECEPTACL	EA	1
12	4	XDHZZ		CS13BF476M	81349 CAPACITOR, ELCTL	EA	1
12	5	PAHZZ	5305-00-054-5645	MS51957-10	96906 SCREW, MACHINE	EA	6
12	6	PAHZZ	5330-00-802-4290	15517	76854 WASHER, FLAT	EA	16
12	7	PAHZZ	5930-00-947-1925	245476A	76854 SWITCH SECTION, ROT A	EA	3
12	8	XDHZZ		15523-3-8	76854 SPACER, SLEEVE	EA	8
12	9	XDHZZ		244494A	76854 SWITCH SECTION, ROT A	EA	3
12	10	XDHZZ		15523-1-4	76854 SPACER, SLEEVE	EA	6
12	11	XDHZZ		756-9197-001	13499 PLATE, GEAR	EA	1
12	12	XDHZZ		756-9195-001	13499 GUIDE, PAWL SPRI	EA	4
12	13	PAHZZ	5360-00-931-9409	756-9185-001	13499 SPRING, HELICAL, COMP	EA	4
12	14	PAHZZ	3120-00-839-3921	2L2FF	96881 BEARING, SLEEVE	EA	7
12	15	PAHZZ	5950-00-906-6388	542-4723-003	13499 COIL, SOLENOID	EA	4
12	16	PAHZZ	5950-00-899-9275	546-8921-003	13499 COIL, SOLENOID	EA	4
12	17	XDHZZ		761-7058-001	13499 PAWL ASSEMBLY	EA	4
12	18	XDHZZ		756-9176-001	13499 NUT, SLEEVE	EA	4
12	19	XDHZZ		542-4510-002	13499 SCREW, SHOULDER	EA	8
12	20	PAHHH	3020-00-752-7989	542-4560-002	13499 GEAR, SPUR	EA	1
12	21	PAHZZ	6625-00-908-7397	761-7059-001	13499 SHAFT	EA	1
12	22	PAHZZ	6625-00-908-7399	548-4713-003	13499 STOP WHEEL	EA	1
12	23	PAHZZ	5821-00-766-1968	542-4525-002	13499 DISK, CLUTCH	EA	1
12	24	XDHZZ		546-5174-002	13499 WASHER, SPRING TENSI	EA	1
12	25	XDHZZ		542-4524-002	13499 NUT, PLAIN, HEXAGON	EA	1
12	26	PAHZZ	5365-00-200-3475	5133-18C	79136 RING, RETAINING	EA	1
12	27	PAHZZ	3120-00-757-2279	3L2FF	96881 BEARING, SLEEVE	EA	7
12	28	XDHZZ		761-7318-001	13499 GEARSHAFT, SPUR	EA	1
12	29	PAHZZ	5365-00-200-3475	5133-18C	79136 RING, RETAINING	EA	5
12	30	PAHZZ	5305-00-054-5637	MS51957-3	96906 SCREW, MACHINE	EA	8
12	31	PAHZZ	5310-00-928-2690	MS35338-134	96906 WASHER, LOCK	EA	8
12	32	XDHZZ		756-9196-001	13499 PLATE, GEAR	EA	1
12	33	PAHZZ	5310-00-933-8118	MS35338-135	96906 WASHER, LOCK	EA	55
12	34	PAHZZ	5305-00-763-7822	MS51959-14	96906 SCREW, MACHINE	EA	8
12	35	PAHZZ	5305-00-978-9343	MS16997-10	96906 SCREW, CAP, SOCKET HE	EA	1
12	36	PAHZZ	5310-00-938-2013	MS35649-24	96906 NUT, PLAIN, HEXAGON	EA	3
12	37	PAHZZ	5310-00-907-0959	310-6320-000	79807 WASHER, FLAT	EA	3
12	38	PAHZZ	5970-00-779-4913	549-3484-002	13499 INSULATOR, ELECTRICA	EA	6
12	39	PAHZZ	5305-00-054-5639	MS51957-5	96906 SCREW, MACHINE	EA	3

SECTION II

(1) ILLUSTRATION (A) FIG NO	(2) ITEM (B) NO	(3) SMR CODE	(4) NATIONAL STOCK NUMBER	(5) PART NUMBER	(6) FSCM	DESCRIPTION	USABLE ON CODE	(7) U/M	(8) QTY INC IN UNIT
12	40	PAOZZ	6240-00-155-7836	MS25237-327	96906	LAMP, INCANDESCENT		EA	3
12	41	PAHZZ	6625-00-908-7394	108-56	02374	INDICATOR, SYMBOL IN		EA	2
12	42	PAHZZ	5305-00-054-5649	MS51957-15	96906	SCREW, MACHINE		EA	8
12	43	PAHZZ	5305-00-716-7733	MS51981-16	96906	SETSCREW		EA	10
12	44	PAHZZ	5355-00-908-7395	761-7057-002	13499	DIAL, SCALE		EA	1
12	45	PAHZZ	5355-00-908-7400	761-7057-001	13499	DIAL, SCALE		EA	3
12	46	PAHZZ	3040-00-950-9578	549-6021-002	13499	COLLAR, SHAFT		EA	1
12	47	XDHZZ		756-9173-001	13499	GEAR, SPUR		EA	1
12	48	XDHZZ		541-1233-003	13499	WASHER, FLA		EA	8
12	49	PAHZZ	3040-00-823-5347	756-9198-001	13499	GEARSHAFT, SPUR		EA	1
12	50	XDHZZ		323-0264-000	74545	SCREW, MACHINE		EA	3
12	51	PAHZZ	3110-00-726-0619	NM0612ZM3J	43334	BEARING, BALL, ANNULA		EA	2
12	52	PAHZZ	6625-00-908-7396	756-9189-001	13499	GEARCLUSTER		EA	1
12	53	XDHZZ		756-9184-001	13499	SPACER, SLEEVE		EA	2
12	54	XDHZZ		756-9193-001	13499	PLATE, GEAR		EA	1
12	55	PAHZZ	5305-00-054-5651	MS51957-17	96906	SCREW, MACHINE		EA	2
12	56	XDHZZ		761-7029-001	13499	SCREW, MACHINE		EA	2
12	57	PAHZZ	5310-00-929-6395	MS35338-136	96906	WASHER, LOCK		EA	4
12	58	XDHZZ		136A146	25140	MOTOR, DIRECT CURREN		EA	1
12	59	XDHZZ		761-7317-001	13499	GEARSHAFT, SPUR		EA	1
12	60	XDHZZ		761-7319-001	13499	GEARSHAFT, SPUR		EA	1
12	61	PAHZZ	5365-00-695-2558	340-0642-00	91314	RING, RETAINING		EA	2
12	62	XDHZZ		756-9177-001	13499	POST, ELENCH		EA	2
12	63	PAHZZ	5305-00-054-6650	MS51957-26	96906	SCREW, MACHINE		EA	4
12	64	PAHZZ	5945-00-854-8546	3SAF1241	01526	RELAY, ARMATURE		EA	5
12	65	PAHZZ	5940-00-700-2971	AB406D	12615	TERMINAL, STUD		EA	1
12	66	XDHZZ		761-7061-001	13499	BRACKET, RELAY		EA	1
12	67	PAHZZ	5310-00-208-3786	P313-0132-00	77250	NUT, PLAIN, HEXAGON		EA	10
12	68	XDHZZ		310-0075-00	79807	WASHER, LOCK		EA	1
12	69	PAHZZ	5310-00-934-9740	MS35649-225	96906	NUT, PLAIN, HEXAGON		EA	1
12	70	XDHZZ		SL174-198	12615	TERMINAL, FEEDTHRU, I		EA	1
12	71	PAHZZ	5940-00-877-8430	TF300	98291	TERMINAL, FEEDTHRU, I		EA	2
12	72	XDHZZ		243888A	76854	SWITCH SECTION, ROTA		EA	1
12	73	PAHZZ	5305-00-054-5642	MS51957-8	96906	SCREW, MACHINE		EA	2

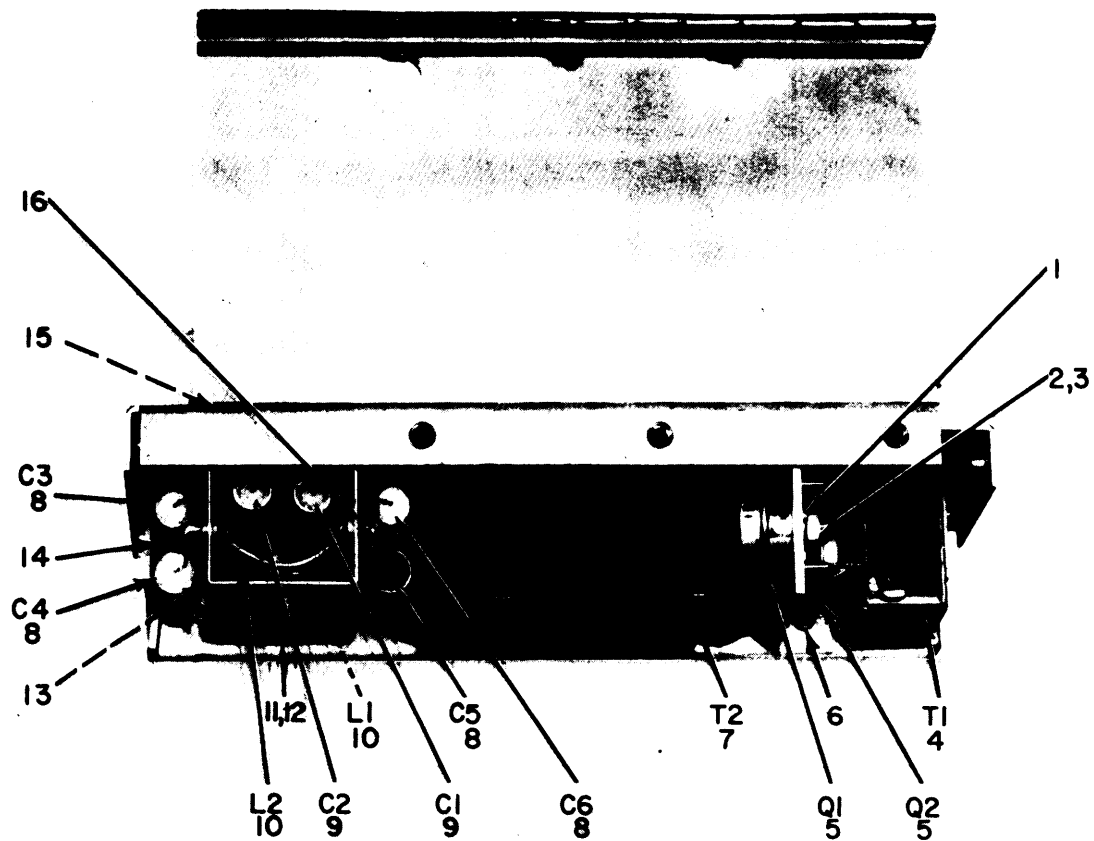

FRONT VIEW

NOTE: FOR COMPLETE REFERENCE DESIGNATION PREFIX WITH AIA3

EL4HK020

Figure 13. Power Converter Assembly (Sheet 1 of 2).

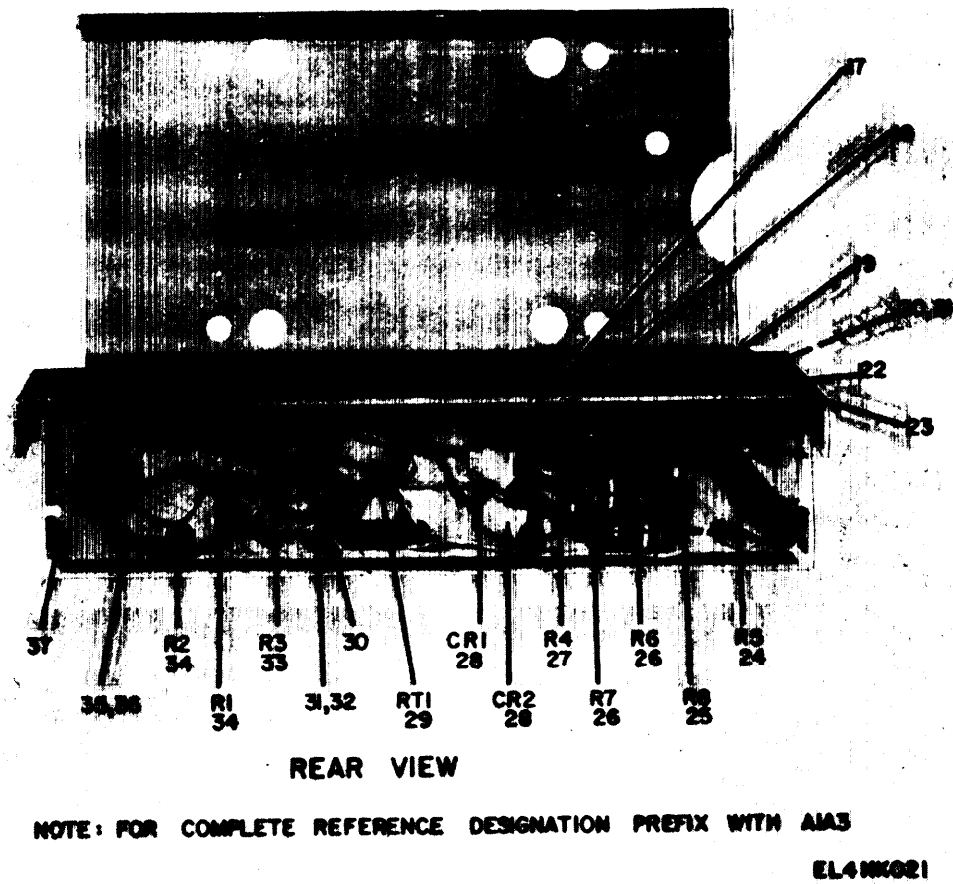
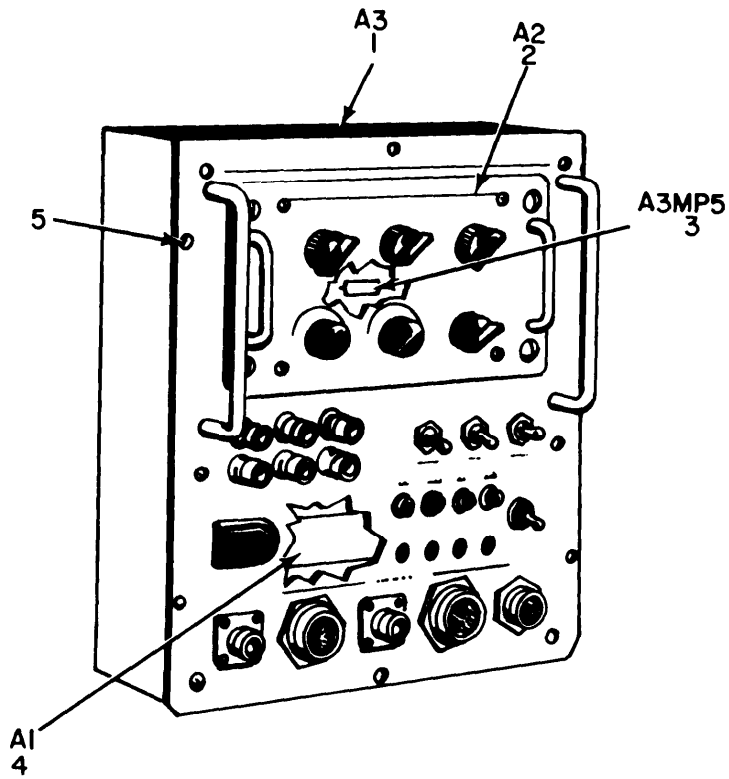

Figure 13. Power Converter Assembly (Sheet 2 of 2).

SECTION II

(1) ILLUSTRATION (A) FIG NO	(2) ITEM NO	(3) SMR CODE	(4) NATIONAL STOCK NUMBER	(5) PART NUMBER	(6) DESCRIPTION FSCM	(7) USABLE ON CODE	(8) QTY INC IN UNIT
13	1	PAHZZ	5940-00-501-8634	4021	77147 TERMINAL,LUG	EA	2
13	2	PAHZZ	5310-00-934-9766	MS35650-305	96906 NUT,SPECAIL	EA	2
13	3	XDHZZ		310-0080-00	79807 WASHER, LOCK	EA	2
13	4	PAHZZ	5950-00-015-6791	36681	73386 TRANSFORMER, POWER, F	EA	1
13	5	PAHZZ	5961-00-649-9371	2N1100	07688 TRANSISTOR	EA	2
13	6	PAHZZ	5305-00-054-5648	MS51957-14	96906 SCREW, MACHINE	EA	3
13	7	XDHZZ		37053	73386 TRANSFORMER, POWER, S	EA	1
13	8	PAHZZ	5910-00-823-1687	CL25BH11UP3	81349 CAPACITOR, FIXED, ELE	EA	4
13	9	PAHZZ	5910-00-134-0623	CL31BX3R3LPE	81349 CAPACITOR, ELCTL	EA	2
13	10	XDHZZ		MP206-2B	95105 COIL, RF	EA	2
13	11	PAHZZ	5305-00-054-6650	MS51957-26	96906 SCREW, MACHINE	EA	2
13	12	PAHZZ	5310-00-929-6395	MS35338-136	96906 WASHER, LOCK	EA	2
13	13	XDHZZ		R3484X3-32	12014 RIVET, TUBULAR	EA	8
13	14	XDHZZ		100-200-16-23	99378 CLIP, SPRING TENSION	EA	4
13	15	PAHZZ	5305-00-770-2533	MS51959-13	96906 SCREW, MACHINE	EA	2
13	16	PAHZZ	5940-00-916-2776	SL314-231	12615 TERMINAL FEEDTHRU	EA	4
13	17	XDHZZ		756-9151-001	13499 POST, ELMCH	EA	2
13	18	PAHZZ	5305-00-054-5637	MS51957-3	96906 SCREW, MACHINE	EA	2
13	19	PAHZZ	5940-00-700-2971	AB406D	12615 TERMINAL, STUD	EA	2
13	20	PAHZZ	5310-00-934-9740	MS35649-225	96906 NUT, PLAIN, HEXAGON	EA	2
13	21	XDHZZ		310-0075-00	79807 WASHER, LOCK	EA	2
13	22	PAHZZ	5940-00-225-6449	SL173-197	12615 TERMINAL, STUD	EA	5
13	23	XDHZZ		SL124-198	12615 TERMINAL, FEEDTH	EA	9
13	24	PAHZZ	5905-00-879-3636	RW67V331	81349 RESISTOR, FIXED, WIRE	EA	1
13	25	XDHZZ		RC42GF683K	81349 RESISTOR, FXD, CM	EA	1
13	26	PAHZZ	5905-00-005-2868	RC42GF393K	81349 RESISTOR, FIXED, COMP	EA	2
13	27	PAHZZ	5905-00-990-0018	RW67V221	81349 RESISTOR, FIXED, WIRE	EA	1
13	28	PAHZZ	5961-00-688-6316	JAN1N547	81350 SEMICONDUCTOR DEVIC	EA	2
13	29	XDHZZ		432H4	10646 RESISTOR, THERMAL	EA	1
13	30	PAHZZ	5940-00-615-8958	2104-06-02-2520N	78189 TERMINAL, LUG	EA	2
13	31	XDHZZ		P343-0330-00	77250 SCREW, MACHINE	EA	2
13	32	PAHZZ	5310-00-184-8977	1108	86376 WASHER, LOCK	EA	2
13	33	PAHZZ	5905-00-975-1128	RW69V391	81349 RESISTOR, FIXED, WIRE	EA	1
13	34	PAHZZ	5905-00-114-5381	RC20GF180K	81349 RESISTOR, FIXED, COMP	EA	2
13	35	PAHZZ	5305-00-054-5647	MS51957-13	96906 SCREW, MACHINE	EA	6
13	36	PAHZZ	5310-00-933-8118	MS35338-135	96906 WASHER, LOCK	EA	4
13	37	XDHZZ		761-7029-002	13499 SCREW, MACHINE	EA	8



NOTE:
FOR COMPLETE REFERENCE DESIGNATION
PREFIX WITH A15

EL4HK022

Figure 14. Test Set, Radio TS-1962/ARC-51X.

SECTION II

(1)	(2)	(3)	(4)	(5)	(6)	(7)	(8)	
ILLUSTRATION							QTY	
(A)	(B)	NATIONAL			DESCRIPTION		INC	
FIG	ITEM	SMR	STOCK	PART			IN	
NO	NO	CODE	NUMBER	NUMBER	FSCM	USABLE ON CODE	U/M	UNIT
GROUP 02 TEST SER,RADIO TS-1962/ARC-51X								
14	1	XDHHH		761-7064-001	13499	TEST UNIT	EA	1
14	2	PAOOO	6625-00-908-7390	761-7066-001	13499	CONTROL,TESTSET	EA	1
14	3	PADHH	5821-00-908-4758	761-7069-001	13499	DETECTOR,AUDIO FREQ	EA	1
14	4	PAOHH	6625-00-908-7384	761-7065-001	13499	AMPLIFIER,AUDIO FRE	EA	1
14	5	XDHZZ		761-7029-003	13499	SCREW,MACHINE	EA	4

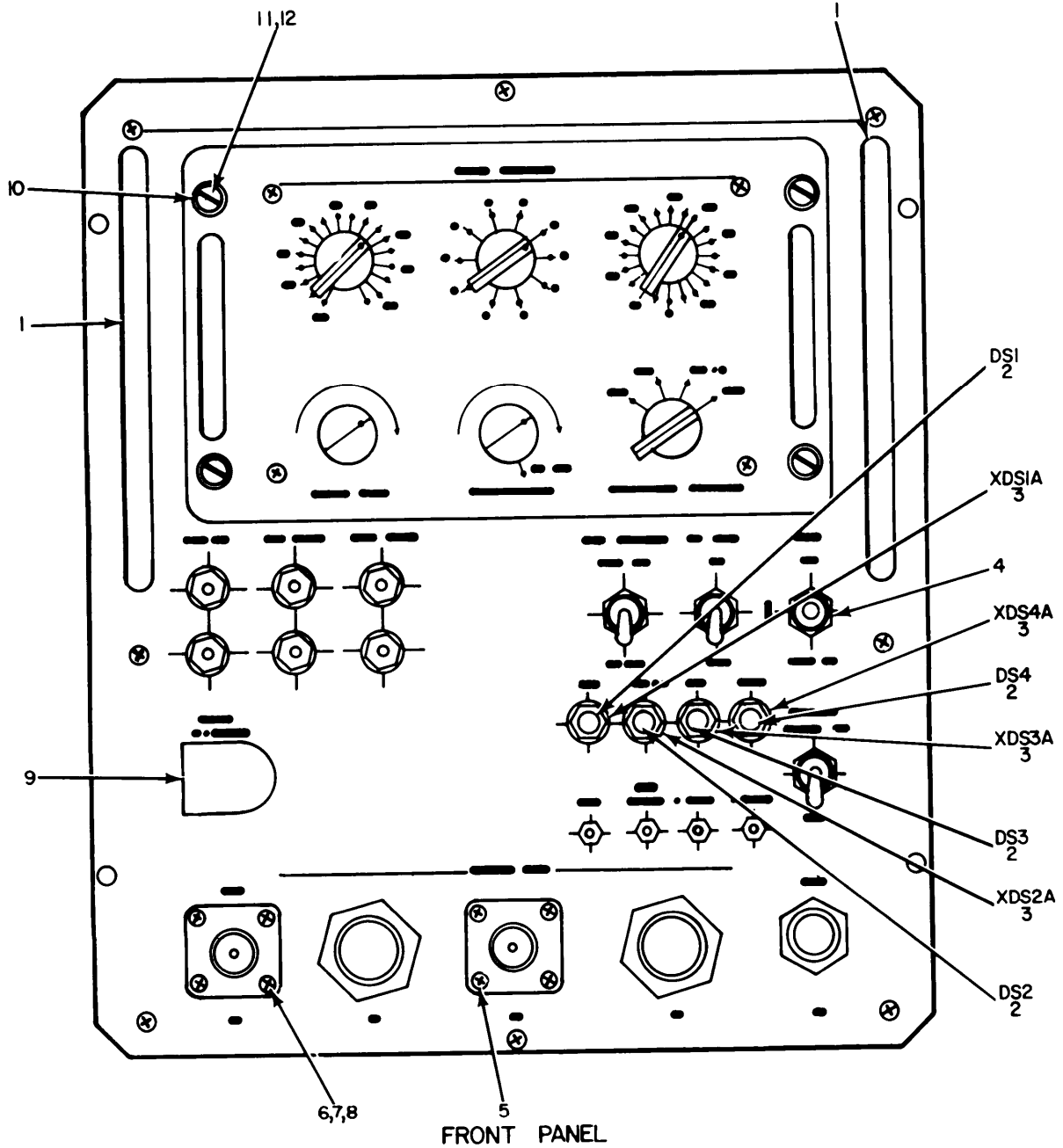

NOTE: FOR COMPLETE REFERENCE
DESIGNATION PREFIX WITH A15A3.

EL4HK023

Figure 15. Test Unit (Sheet 1 of 3).

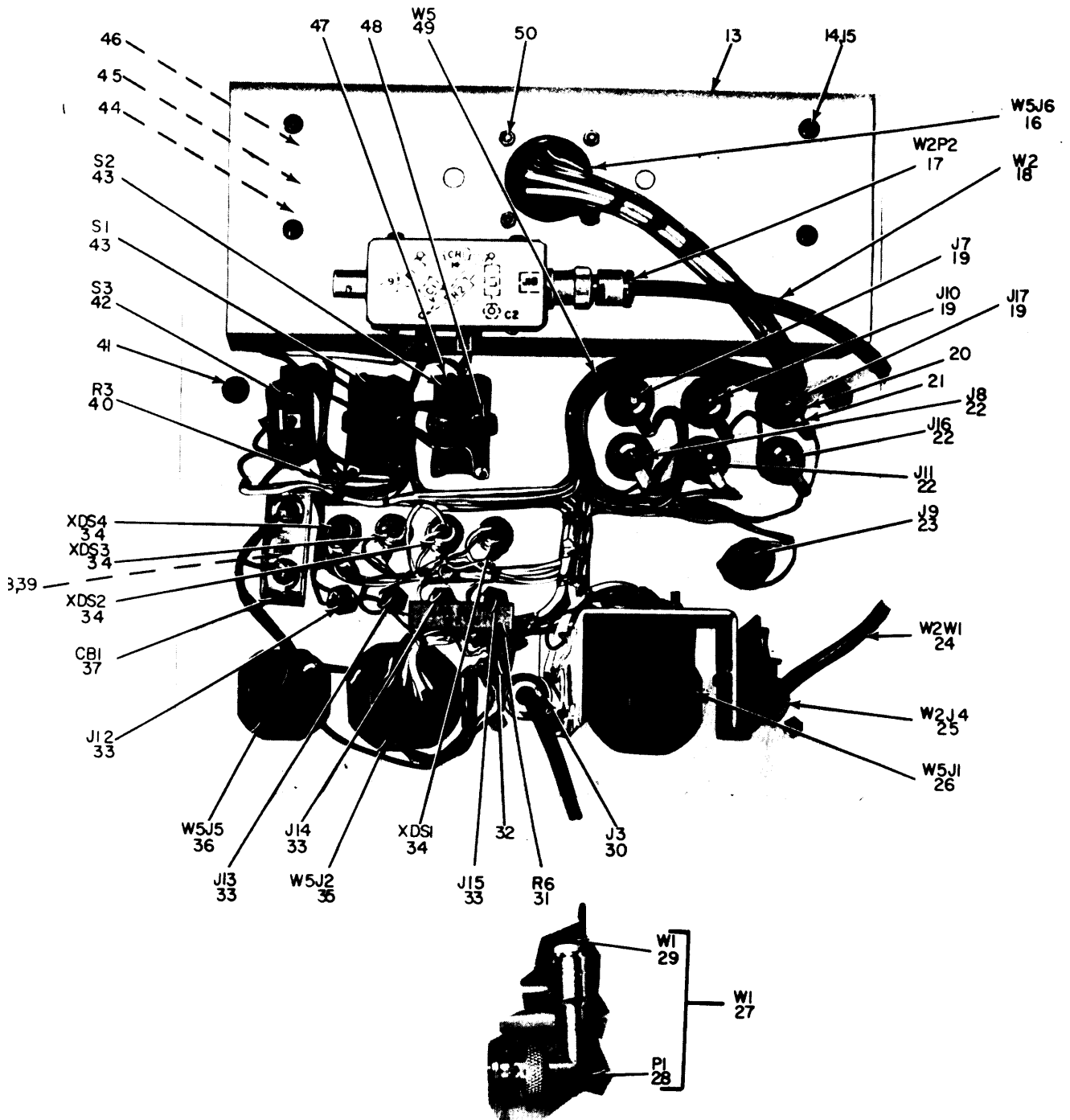

FRONT PANEL REAR VIEW

NOTE: FOR COMPLETE REFERENCE DESIGNATION
 PREFIX WITH A15A3

Figure 15. Test Unit (Sheet 2 of 3).

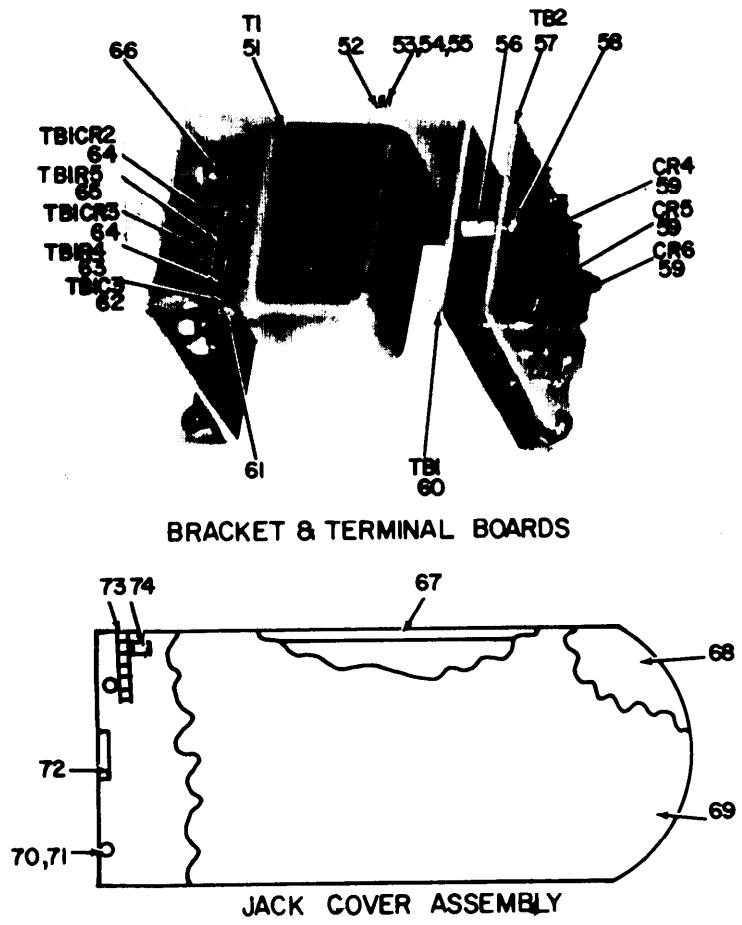

NOTE: FOR COMPLETE REFERENCE DESIGNATION PREFIX WITH A15A3.
EL4HK025

Figure 15. Test Unit (Sheet 3 of 3).

SECTION II

(1) ILLUSTRATION (A) FIG NO	(2) (B) ITEM NO	(3) SMR CODE	(4) NATIONAL STOCK NUMBER	(5) PART NUMBER	(6) DESCRIPTION FSCM	(7) USABLE ON CODE U/M	(8) QTY INC IN UNIT
GROUP 0201 TEST UNIT							
15	1	XDHZZ		2102	36577 HANDLE, BOW	EA	2
15	2	PAOZZ	6240-00-155-7836	MS25237-327	96906 LAMP, INCANDESCENT	EA	4
15	3	PAOZZ	6210-00-767-6246	855020R	08717 LENS, IND, LIGHT	EA	4
15	4	XDHZZ		761-0012-003	13499 WASHER, FLAT	EA	3
15	5	PAHZZ	5305-00-207-7465	P343-0287-00	77250 SCREW, MACHINE	EA	3
15	6	PAHZZ	5310-00-493-1738	P313-0051-00	77250 NUT, PLAIN, HEXAGON	EA	8
15	7	PAHZZ	5305-00-207-7463	P343-0288-00	77250 SCREW, MACHINE	EA	8
15	8	PAHZZ	5310-00-184-8996	310009500	70117 WASHER, LOCK	EA	8
15	9	PAHHH	6625-00-702-0287	761-7035-001	13499 COVER ASSY, JACK	EA	1
15	10	PAHZZ	5325-00-505-4798	212-12	71286 RECEPTACLE, TURNLOCK	EA	4
15	11	PAHZZ	5310-00-938-2013	MS35649-24	96906 NUT, PLAIN, HEXAGON	EA	2
15	12	PAHZZ	5305-00-764-2964	MS51959-4	96906 SCREW, MACHINE	EA	2
15	13	XDHZZ		756-8871-001	13499 BRACKET, ELEC, CO	EA	1
15	14	PAHZZ	5305-00-054-6652	MS51957-28	96906 SCREW, MACHINE	EA	12
15	15	PAHZZ	5310-00-929-6395	MS35338-136	96906 WASHER, LOCK	EA	4
15	16	PAHZZ	5935-00-809-8808	MS3112E18-32P	96906 CONNECTOR, RECEPTACL	EA	1
15	17	PAHZZ	5935-00-823-0487	MS35168-88E	96906 CONNECTOR, PLUG, ELEC	EA	1
15	18	XDHHH		761-7074-001	13499 CABLE ASSEMBLY	EA	1
15	19	PAHZZ	5940-00-356-2493	DF30RC	58474 POST, BINDING, ELECTR	EA	3
15	20	PAHZZ	5310-00-261-8278	310-0100-000	13499 WASHER, LOCK	EA	6
15	21	PAHZZ	5940-00-501-8634	4021	77147 TERMINAL, LUG	EA	6
15	22	PAHZZ	5940-00-269-2219	DF308C	58474 POST, BINDING	EA	3
15	23	PAHZZ	5935-00-906-6334	756-8876-001	13499 JACK, TIP	EA	1
15	24	PAHZZ	6145-00-542-6092	RG58CU	80058 CABLE, RADIO FREQUEN	FT	1
15	25	PAHZZ	5935-00-969-6996	101N3100A25	94375 CONNECTOR, RECEPTACL	EA	1
15	26	PAHZZ	5935-00-951-9331	MS3114E16-26PW	96906 CONNECTOR, RECEPTACL	EA	1
15	27	XDHHH		761-7073-001	13499 CABLE ASSEMBLY	EA	1
15	28	PAHZZ	5935-00-682-0501	MS35367-913A	96906 CONNECTOR, PLUG, ELEC	EA	1
15	29	PAHZZ	6145-00-542-6092	RG58CU	80058 CABLE, RADIO FREQUEN	FT	1
15	30	PAHZZ	5935-00-969-6996	101N3100A25	94375 CONNECTOR, RECEPTACL	EA	1
15	31	PAHZZ	5905-00-910-9485	PW7-15000P0RM10PCT	07716 RESISTOR, FXD, WW	EA	1
15	32	PAHZZ	5940-00-738-1265	547-5305-002	13499 TERMINAL, LUG	EA	1
15	33	PAHZZ	5935-00-578-3489	MS16108-2A	96906 JACK, TIP	EA	4
15	34	PAHZZ	6210-00-881-1507	855029-9	08717 LIGHT, INDICATOR	EA	4
15	35	PAHZZ	5935-00-836-1804	MS3114E16-26P	96906 CONNECTOR, RECEPTACL	EA	1
15	36	PAHZZ	5935-00-845-2537	MS3114E12-3P	96906 CONNECTOR, RCPT	EA	1
15	37	XDHZZ		SM3-15-2-50VDC	74193 CIRCUIT BREAKER	EA	1
15	38	XDHZZ		505-1504-001	13499 WASHER, FLAT	EA	1
15	39	PAHZZ	5310-00-883-5931	410894-38	96214 WASHER, LOCK	EA	5

SECTION II

(1) ILLUSTRATION (A) FIG NO	(2) (B) ITEM NO	(3) SMR CODE	(4) NATIONAL STOCK NUMBER	(5) PART NUMBER	(6) FSCM	DESCRIPTION	(7) USABLE ON CODE	(8) QTY INC IN UNIT
15	40	PAHZZ	5905-00-279-1756	RC20GF151K	81349	RESISTOR, FIXED, COMP	EA	1
15	41	PAHZZ	5305-00-071-1320	MS35201-53	96906	SCREW, MACHINE	EA	2
15	42	PAHZZ	5930-00-655-1523	MS35058-31	96906	SWITCH, TOGGLE	EA	1
15	43	PAHZZ	5930-00-655-1582	MS35059-23	96906	SWITCH, TOGGLE	EA	2
15	44	XDHZZ		756-8835-001	13499	POST, ELMCH	EA	2
15	45	PAHZZ	5305-00-054-6651	MS51957-27	96906	SCREW, MACHINE	EA	4
15	46	XDHZZ		756-8834-001	13499	POST, ELMCH	EA	2
15	47	PAHZZ	5940-00-878-3768	4007-6	77147	TERMINAL, LUG	EA	15
15	48	XDHZZ		1A1S4H2	79807	WASHER, LOCK	EA	15
15	49	XDHHH		761-7075-001	13499	WIRING HARNESS	EA	1
15	50	PAHZZ	5305-00-054-5648	MS51957-14	96906	SCREW, MACHINE	EA	4
15	51	PAHZZ	5950-00-944-9906	32867	80089	TRANSFORMER, AUDIO F	EA	1
15	52	PAHZZ	5940-00-682-2477	2104-04-01-2520N	78189	TERMINAL, LUG	EA	1
15	53	PAHZZ	5310-00-208-3786	P313-0132-00	77250	NUT, PLAIN, HEXAGON	EA	6
15	54	PAHZZ	5310-00-782-1349	310-0045-00	79807	WASHER, FLAT	EA	2
15	55	PAHZZ	5305-00-054-5648	MS51957-14	96906	SCREW, MACHINE	EA	6
15	56	PAHZZ	5820-00-086-8724	540-9002-003	13499	POST	EA	2
15	57	XDHHH		761-7071-001	13499	RECTIFIER ASSEM	EA	1
15	58	PAHZZ	5305-00-054-5636	MS51957-2	96906	SCREW, MACHINE	EA	4
15	59	PAHZZ	5961-00-577-6214	JAN1N538	81350	SEMICONDUCTOR DEVIC	EA	3
15	60	XDHHH		761-7072-001	13499	TERMINAL BOARD	EA	1
15	61	XDHZZ		SL158-198	12615	TERMINAL, FEEDTHRU, I	EA	2
15	62	PAHZZ	5910-00-420-8555	CS13BF225M	81349	CAPACITOR, FIXED, ELE	EA	1
15	63	PAHZZ	5905-00-279-2616	RC20GF153J	81349	RESISTOR, FIXED, COMP	EA	1
15	64	PAHZZ	5961-00-985-4900	JAN1N647	81349	SEMICONDUCTOR, D	EA	2
15	65	PAHZZ	5905-00-279-1877	RC20GF242J	81349	RESISTOR, FIXED, COMP	EA	1
15	66	PAHZZ	5940-00-225-6449	SL173-197	12615	TERMINAL, STUD	EA	3
15	67	XDHZZ		756-8890-001	13499	BRACKET, JACK	EA	1
15	68	XDHZZ		756-8885-001	13499	INSERT, JACK COV	EA	1
15	69	XDHZZ		756-8887-001	13499	COVER, JACK	EA	1
15	70	PAHZZ	5305-00-054-5638	MS51957-4	96906	SCREW, MACHINE	EA	2
15	71	PAHZZ	5310-00-928-2690	MS35338-134	96906	WASHER, LOCK	EA	12
15	72	XDHZZ		756-8889-001	13499	SPACER, PLATE	EA	1
15	73	PAHZZ	5315-00-297-0875	MS171444	96906	PIN, SPRING	EA	1
15	74	XDHZZ		756-8886-001	13499	SPRING, HELICAL, TORS	EA	1

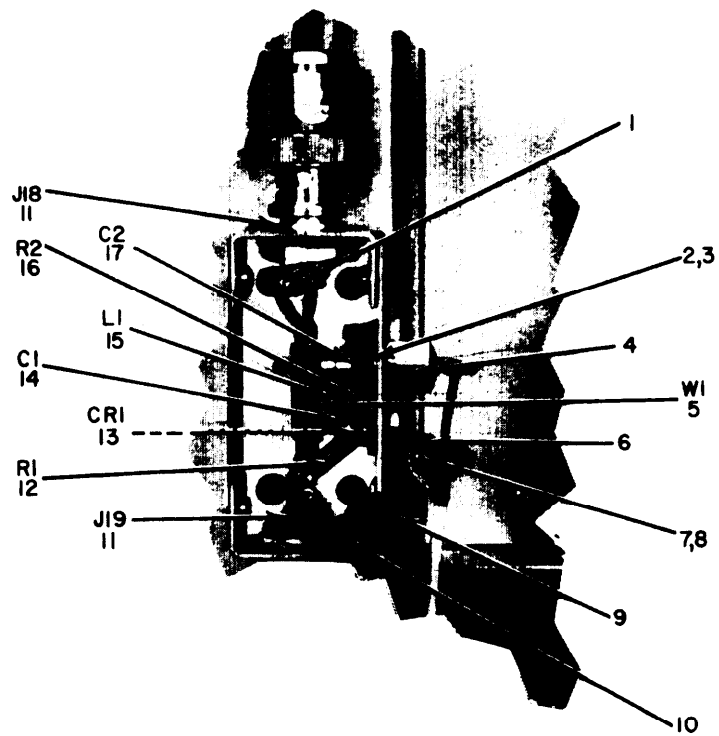

NOTE FOR COMPLETE REFERENCE DESIGNATION
PREFIX WITH A15A3MP5

EL4HK026

Figure 16. Detector Assembly.

SECTION II

(1) ILLUSTRATION (A) FIG NO	(2) (B) ITEM NO	(3) SMR CODE	(4) NATIONAL STOCK NUMBER	(5) PART NUMBER	(6) DESCRIPTION FSCM	(7) USABLE ON CODE U/M	(8) QTY INC IN UNIT
GROUP 0202 DETECTOR ASSEMBLY							
16	1	XDHZZ		4090	77147 TERMINAL,LUG	EA	2
16	2	PAHZZ	5310-00-685-7739	334-0043-000	13499 NUT,PLAIN,HEXAGON	EA	1
16	3	XDHZZ		310-0400-00	79807 WASHER,LOCK	EA	1
16	4	PAHZZ	5940-00-225-6449	SL173-197	12615 TERMINAL,STUD	EA	2
16	5	PAHZZ	6145-00-080-6517	RG303U	81349 CABLE,RF	FT	1
16	6	PAHZZ	5940-00-700-2971	AB406D	12615 TERMINAL,STUD	EA	1
16	7	XDHZZ		310-0075-00	79807 WASHER,KEY	EA	1
16	8	PAHZZ	5310-00-934-9740	MS35649-225	96906 NUT,PLAIN,HEXAGON	EA	1
16	9	PAHZZ	5305-00-637-5884	P343-0285-00	77250 SCREW,MACHINE	EA	4
16	10	XDHZZ		756-8875-001	13499 COVER,DETECTOR	EA	1
16	11	PAHZZ	5935-00-552-7660	UG625BU	80058 CONNECTOR,RECEPTACL	EA	2
16	12	PAHZZ	5905-00-195-6817	RC20GF102K	81349 RESISTOR,FIXED,COMP	EA	1
16	13	PAHZZ	5961-00-556-2091	JAN1N270	81349 SEMICONDUCTOR,D	EA	1
16	14	PAHZZ	5910-00-060-1189	CM05F271J03	81349 CAPACITOR,FXD,M	EA	1
16	15	PAHZZ	5950-00-764-3186	MS18130-2	96906 COIL,RADIO FREQUENC	EA	1
16	16	PAHZZ	5905-00-190-8879	RC20GF183K	81349 RESISTOR,FIXED,COMP	EA	1
16	17	PAHZZ	5910-00-804-7566	327-029X5T0102Z	72982 CAPACITOR,FIXED,CE	EA	1

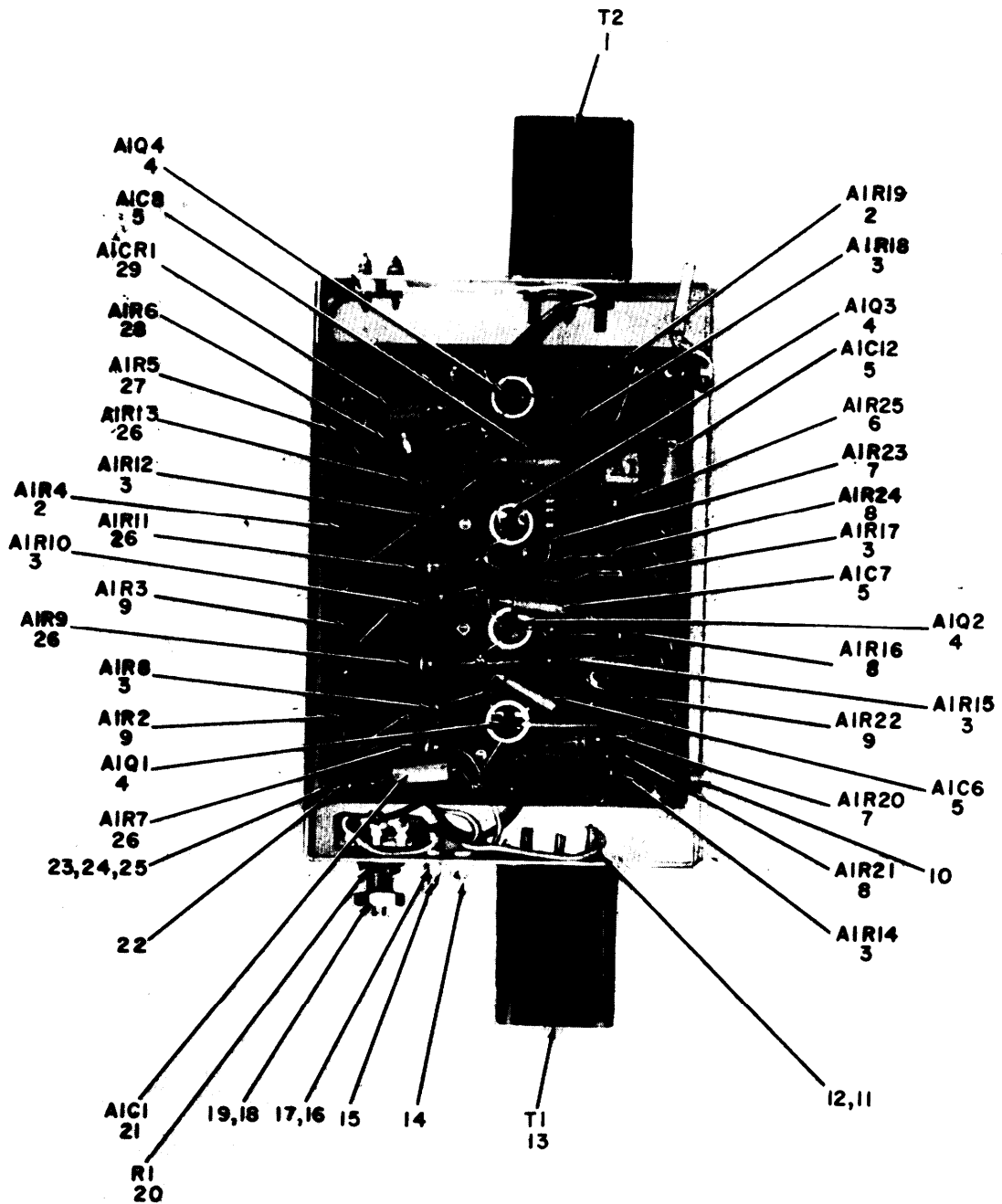

FRONT VIEW TERMINAL BOARD

**NOTE: FOR COMPLETE REFERENCE DESIGNATION
PREFIX WITH A15A1.**

EL4HK027

Figure 17. Amplifier Assembly, AF (761-7065-001) (Sheet 1 of 2).

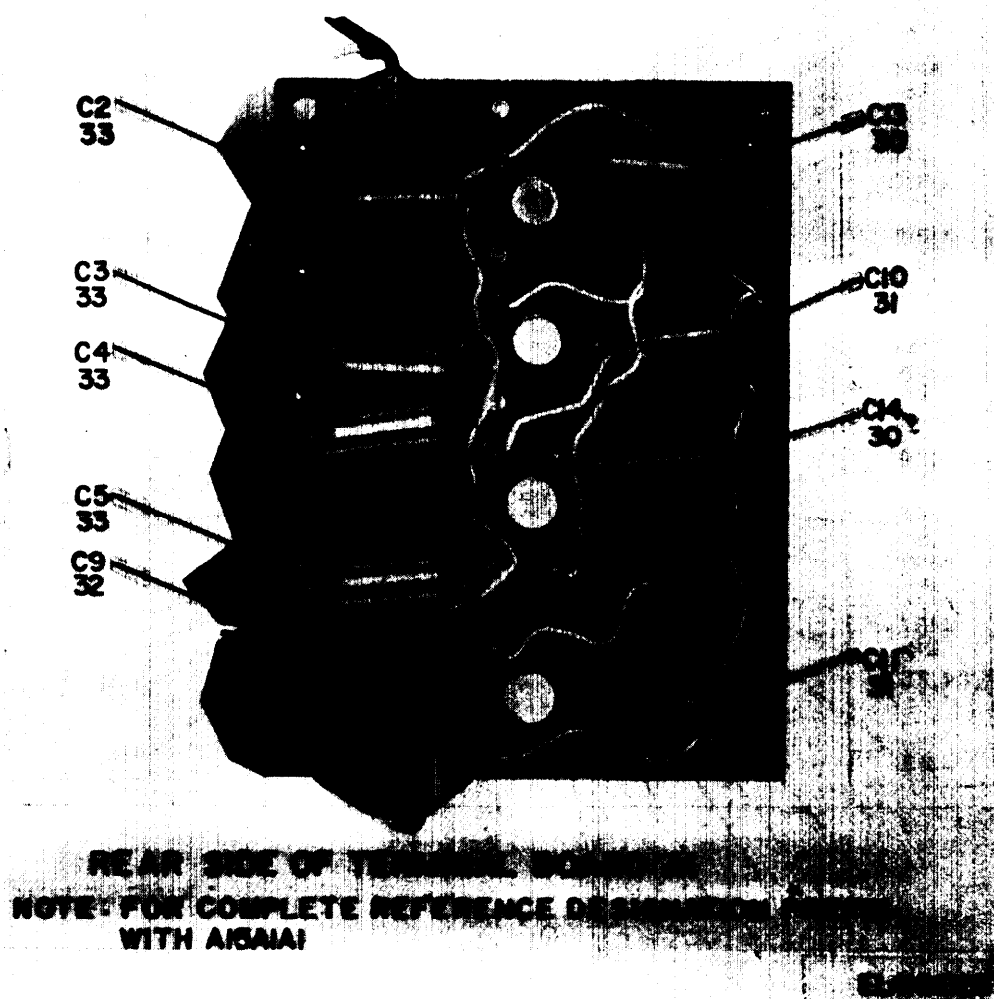
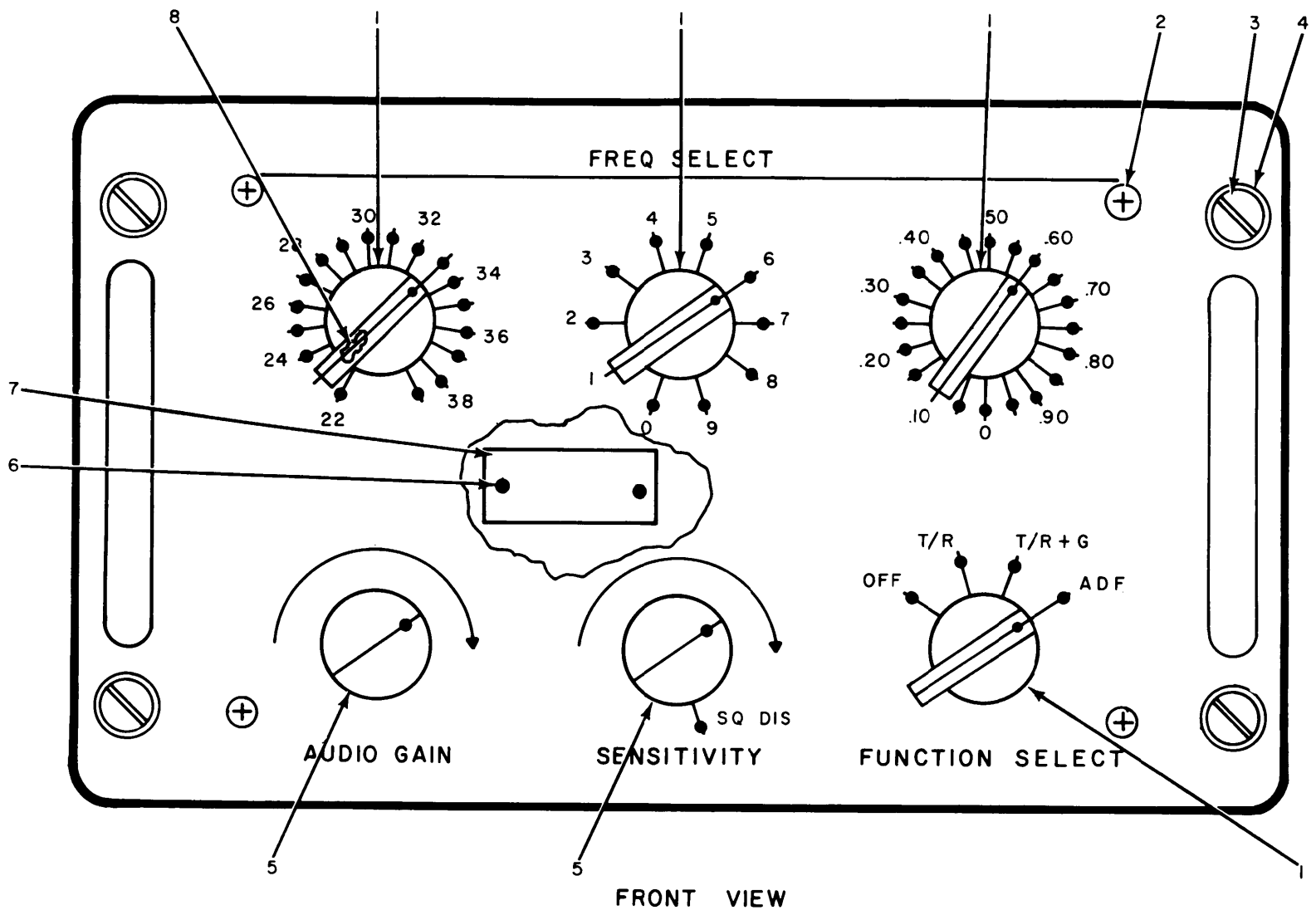

Figure 17. Amplifier Assembly, AF (761-7065-001) (Sheet 2 of 2).

SECTION II

(1) ILLUSTRATION (A) FIG NO	(2) (B) ITEM NO	(3) SMR CODE	(4) NATIONAL STOCK NUMBER	(5) PART NUMBER	(6) DESCRIPTION FSCM	(7) USABLE ON CODE U/M	(8) QTY INC IN UNIT
GROUP 0203 AMPLIFIER ASSEMBLY, AF							
(761-7065-001)							
17	1	XDHZZ		37346	73386 TRANSFORMER, AUDIO F	EA	1
17	2	PAHZZ	5905-00-195-6800	RC20GF561J	81349 RESISTOR, FIXED, COMP	EA	2
17	3	PAHZZ	5905-00-195-6453	RC20GF562J	81349 RESISTOR, FIXED, COMP	EA	7
17	4	PAHZZ	5961-00-837-7262	MIL-S-19500/99	81349 TRANSISTOR	EA	4
17	5	XDHZZ		CS13BD106M	81349 CAPACITOR, ELCTL	EA	4
17	6	PAHZZ	5905-00-279-1876	RC20GF222J	81349 RESISTOR, FIXED, COMP	EA	1
17	7	PAHZZ	5905-00-192-4490	RC20GF330J	81349 RESISTOR, FIXED, COMP	EA	2
17	8	PAHZZ	5905-00-279-1880	RC20GF272J	81349 RESISTOR, FIXED, COMP	EA	3
17	9	PAHZZ	5905-00-195-6806	RC20GF102J	81349 RESISTOR, FIXED, COMP	EA	3
17	10	XDHZZ		761-7029-004	13499 SCREW, MACHINE	EA	4
17	11	PAHZZ	5310-00-208-3786	P313-0132-00	77250 NUT, PLAIN, HEXAGON	EA	4
17	12	PAHZZ	5310-00-782-1349	310-0045-00	79807 WASHER, FLAT	EA	4
17	13	PAHZZ	5950-00-906-6392	36677	73386 TRANSFORMER, AUDIO F	EA	1
17	14	XDHZZ		SL158-198	12615 TERMINAL, FEEDTHRU, I	EA	5
17	15	PAHZZ	5940-00-700-2971	AB406D	12615 TERMINAL, STUD	EA	1
17	16	PAHZZ	5310-00-934-9740	MS35649-225	96906 NUT, PLAIN, HEXAGON	EA	1
17	17	XDHZZ		310-0075-00	79807 WASHER, LOCK	EA	2
17	18	XDHZZ		P334-0266-00	77250 NUT, PLAIN, HEXAGON	EA	1
17	19	XDHZZ		1714-05CADPL	78189 WASHER, LOCK	EA	1
17	20	PAHZZ	5905-00-644-9545	RV5LAYS2538	81349 RESISTOR, VARIABLE, N	EA	1
17	21	PAHZZ	5910-00-904-3985	CS13BF685M	81349 CAPACITOR FIXED ELE	EA	1
17	22	PAHZZ	5310-00-053-1551	540-9041-003	13499 NUT, PLAIN, HEXAGON	EA	4
17	23	PAHZZ	5305-00-054-5647	MS51957-13	96906 SCREW, MACHINE	EA	8
17	24	PAHZZ	5310-00-903-1509	502-1515-002	13499 WASHER, FLAT	EA	4
17	25	PAHZZ	5310-00-933-8118	MS35338-135	96906 WASHER, LOCK	EA	8
17	26	PAHZZ	5905-00-279-2616	RC20GF153J	81349 RESISTOR, FIXED, COMP	EA	4
17	27	PAHZZ	5905-00-299-1541	RC20GF151J	81349 RESISTOR FIXED C	EA	1
17	28	PAHZZ	5905-00-247-8722	RC32GF271J	81349 RESISTOR, FIXED, COMP	EA	1
17	29	PAHZZ	5961-00-837-9287	1N3025	81349 SEMICONDUCTOR DEVIC	EA	1
17	30	PAHZZ	5910-00-010-8158	CS1388157M	81349 CAPACITOR, FIXED, ELE	EA	2
17	31	XDHZZ		CS1388476M	81349 CAPACITOR, ELCTL	EA	2
17	32	PAHZZ	5910-00-043-1994	CM06F471J03	81349 CAPACITOR, FIXED, MIC	EA	1
17	33	PAHZZ	5910-00-993-2201	CSR13E476KL	81349 CAPACITOR, ELCTL	EA	4



NOTE: FOR COMPLETE REFERENCE DESIGNATION PREFIX WITH A15A2.

EL4HK029

Figure 18. Control, Test Set (Sheet 1 of 2).

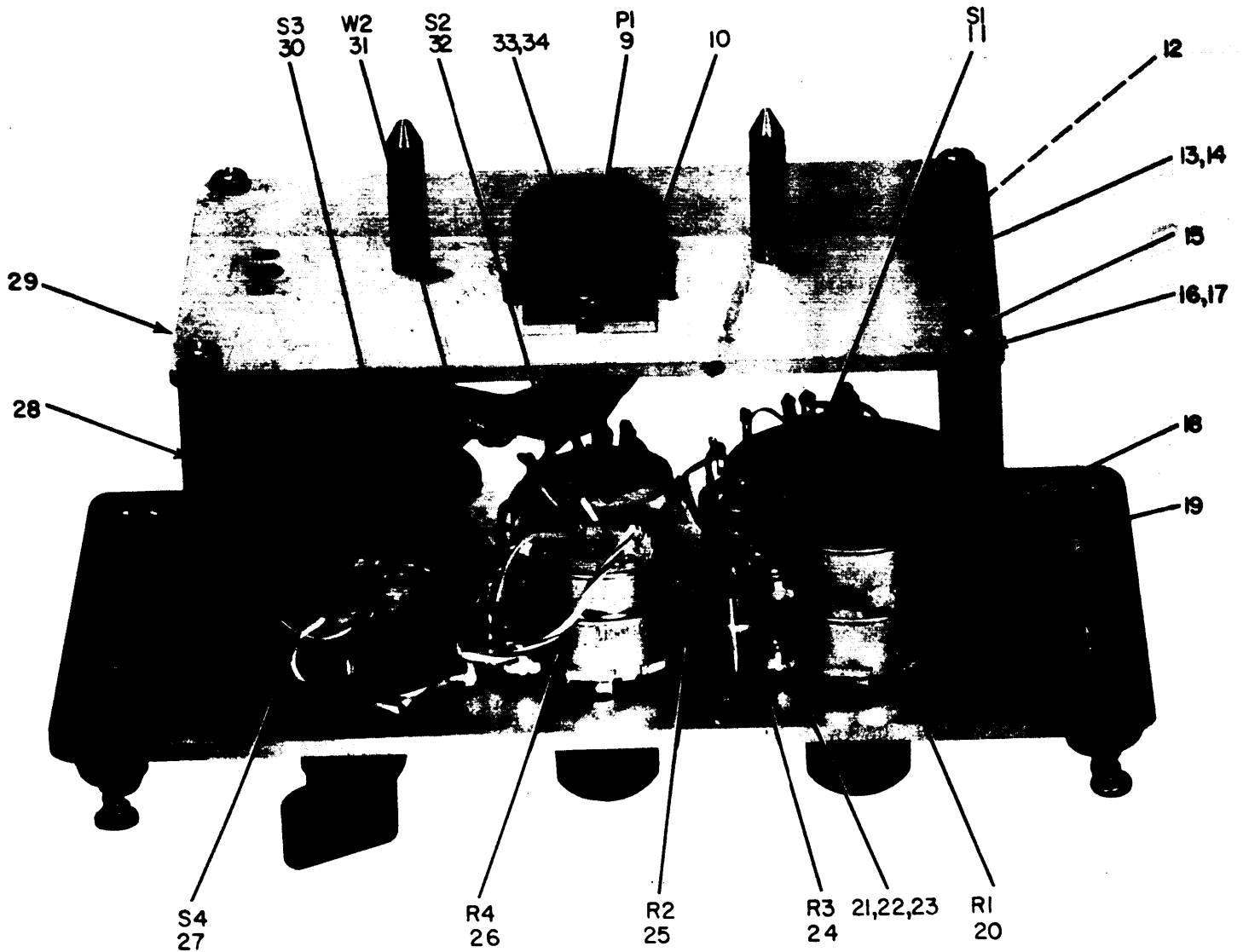

NOTE FOR COMPLETE REFERENCE DESIGNATION PREFIX WITH A15A2

INTERNAL VIEW

EL4HK030

Figure 18. Control, Test Set (Sheet 2 of 2).

SECTION II

(1) ILLUSTRATION (A) FIG NO	(2) (B) ITEM NO	(3) SMR CODE	(4) NATIONAL STOCK NUMBER	(5) PART NUMBER	(6) FSCM	DESCRIPTION	USABLE ON CODE	(7) U/M	(8) QTY INC IN UNIT
GROUP 0204 CONTROL, TEST SET									
18	1	PAOZZ	5355-00-702-2704	757-0231-001	13499	KNOB		EA	4
18	2	PAOZZ	5305-00-054-6652	MS51957-28	96906	SCREW, MACHINE		EA	4
18	3	PAOZZ	5325-00-290-3969	2600-8	71286	STUD ASSEMBLY, TURN		EA	4
18	4	PAOZZ	5310-00-639-7435	2600SW2	13499	WASHER, SPLIT		EA	4
18	5	PAOZZ	5355-00-909-0465	757-0228-001	13499	KNOB		EA	2
18	6	PAOZZ	5305-00-054-5635	MS51957-1	96906	SCREW, MACHINE		EA	2
18	7	XDOZZ		767-0745-000	13499	PLATE, IDENT		EA	1
18	8	PAOZZ	5305-00-719-5342	MS51981-26	96906	SETSCREW		EA	12
18	9	PAOZZ	5935-00-906-6335	756-8841-001	13499	CONNECTOR, RECEPTACL		EA	1
18	10	XDOZZ		756-8846-001	13499	PLATE, POSN, CONN		EA	1
18	11	PAOZZ	5930-00-944-9837	237164RK1	76854	SWITCH, ROTARY		EA	1
18	12	PAOZZ	5325-00-285-3373	012-1194-00	13499	LOCKSPRING TURN		EA	2
18	13	PAOZZ	5310-00-938-2013	MS35649-24	96906	NUT, PLAIN, HEXAGON		EA	4
18	14	PAOZZ	5305-00-764-2964	MS51959-4	96906	SCREW, MACHINE		EA	4
18	15	PAOZZ	5305-00-054-6651	MS51957-27	96906	SCREW, MACHINE		EA	5
18	16	PAOZZ	5310-00-907-0959	310-6320-000	79807	WASHER, FLAT		EA	4
18	17	PAOZZ	5310-00-928-2690	MS35338-134	96906	WASHER, LOCK		EA	16
18	18	XDOZZ		756-8834-002	13499	POST, ELMCH		EA	2
18	19	PAOZZ	5305-00-763-6962	MS51959-27	96906	SCREW, MACHINE		EA	4
18	20	PAOZZ	5905-00-954-6432	NX24429	71450	RESISTOR, VARIABLE, N		EA	1
18	21	PAOZZ	5310-00-275-5147	P334-4120-00	77250	NUT, PLAIN, HEXAGON		EA	6
18	22	XDOZZ		505-1504-001	13499	WASHER, FLAT		EA	6
18	23	PAOZZ	5310-00-883-5931	410894-38	96214	WASHER, LOKC		EA	6
18	24	PAOZZ	5905-00-171-1975	RC42GF151K	81349	RESISTOR, FIXED, COMP		EA	1
18	25	PAOZZ	5905-00-279-1756	RC20GF151K	81349	RESISTOR, FIXED, COMP		EA	1
18	26	PAOZZ	5905-00-954-6899	NX24427	71450	RESISTOR, VARIABLE, N		EA	1
18	27	PAOZZ	5930-00-944-9835	236923BA1	76854	SWITCH, ROTARY		EA	1
18	28	XDOZZ		756-8835-002	13499	POST, ELMCH		EA	2
18	29	XDOZZ		756-8837-002	13499	PLATE, RETAINING		EA	1
18	30	PAOZZ	5930-00-944-9836	238191RK2	76854	SWITCH, ROTARY		EA	1
18	31	XDOOO		761-7078-001	13499	WIRING HARNESS		EA	1
18	32	PAOZZ	5930-00-944-9838	236922BA1	76854	SWITCH, ROTARY		EA	1
18	35	PAOZZ	5310-00-515-8243	310-0046-00	79807	WASHER, FLAT		EA	1
18	34	PAOZZ	5310-00-929-6395	MS35338-136	96906	WASHER, LOCK		EA	5



NOTE: FOR COMPLETE REFERENCE DESIGNATION PREFIX WITH A8

EL4HK03I

Figure 19. Antenna AS-1484/ARC-51 X.

SECTION II

(1)	(2)	(3)	(4)	(5)	(6)	(7)	(8)	
ILLUSTRATION							QTY	
(A)	(B)	NATIONAL			DESCRIPTION		INC	
FIG	ITEM	SMR	STOCK	PART			IN	
NO	NO	CODE	NUMBER	NUMBER	FSCM	USABLE ON CODE	U/M	UNIT

GROUP 03 ANTENNA AS-1484/ARC-51X

19	1	PAOZZ	5935-00-928-3127	UG21E/U	80058	CONNECTOR, PLUG, ELEC	EA	1
----	---	-------	------------------	---------	-------	-----------------------	----	---

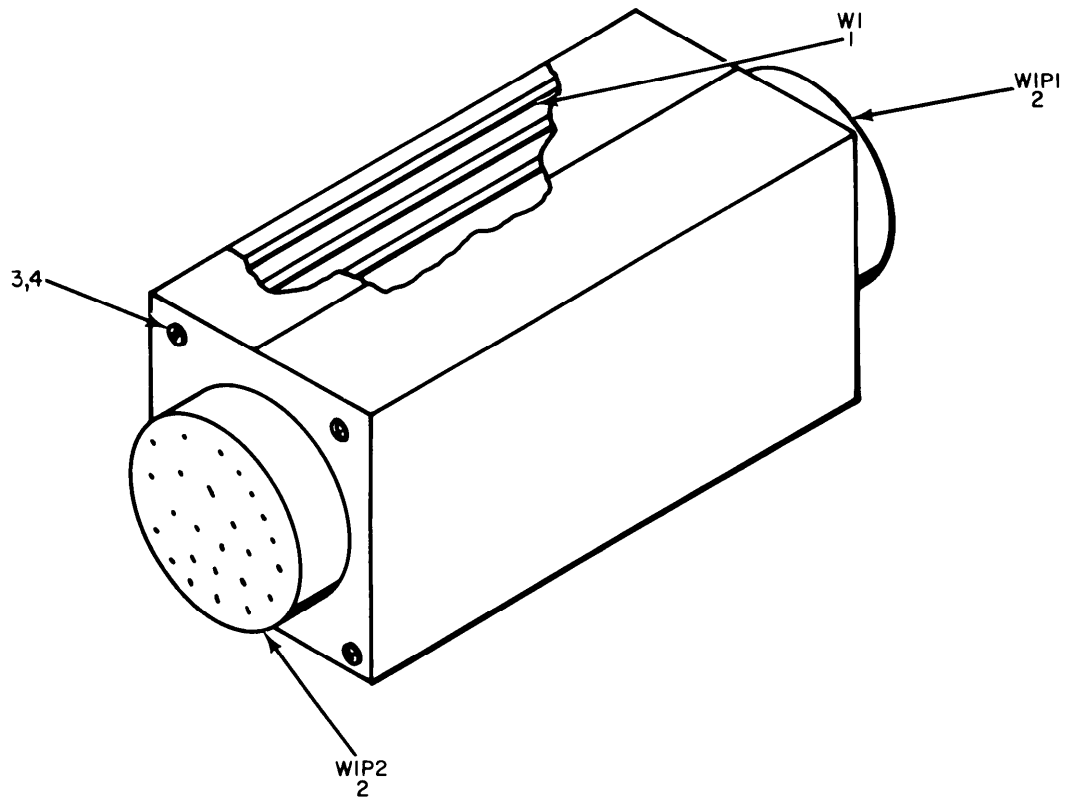

NOTE : FOR COMPLETE REFERENCE DESIGNATION PREFIX WITH A2.

EL4HK032

Figure 20. Adapter, Connector U-335/ARC-51X.

SECTION II

(1)	(2)	(3)	(4)	(5)	(6)	(7)	(8)	
ILLUSTRATION							QTY	
(A)	(B)	NATIONAL			DESCRIPTION		INC	
FIG	ITEM	SMR	STOCK	PART			IN	
NO	NO	CODE	NUMBER	NUMBER	FSCM	USABLE ON CODE	U/M	UNIT
GROUP 04 ADAPTER,CONNECTOR U-35/ARC-51X								
20	1	XD000		761-7020-001	13499	WIRING HARNESS	EA	1
20	2	PAOZZ	5935-00-823-0212	MS3112E16-26PW	96906	CONNECTOR,RECEPTACL	EA	2
20	3	PAOZZ	5305-00-054-5647	MS51957-13	96906	SCREW,MACHINE	EA	8
20	4	PAOZZ	5310-00-058-2949	310-0278-000	70318	WASHER,LOCK	EA	8

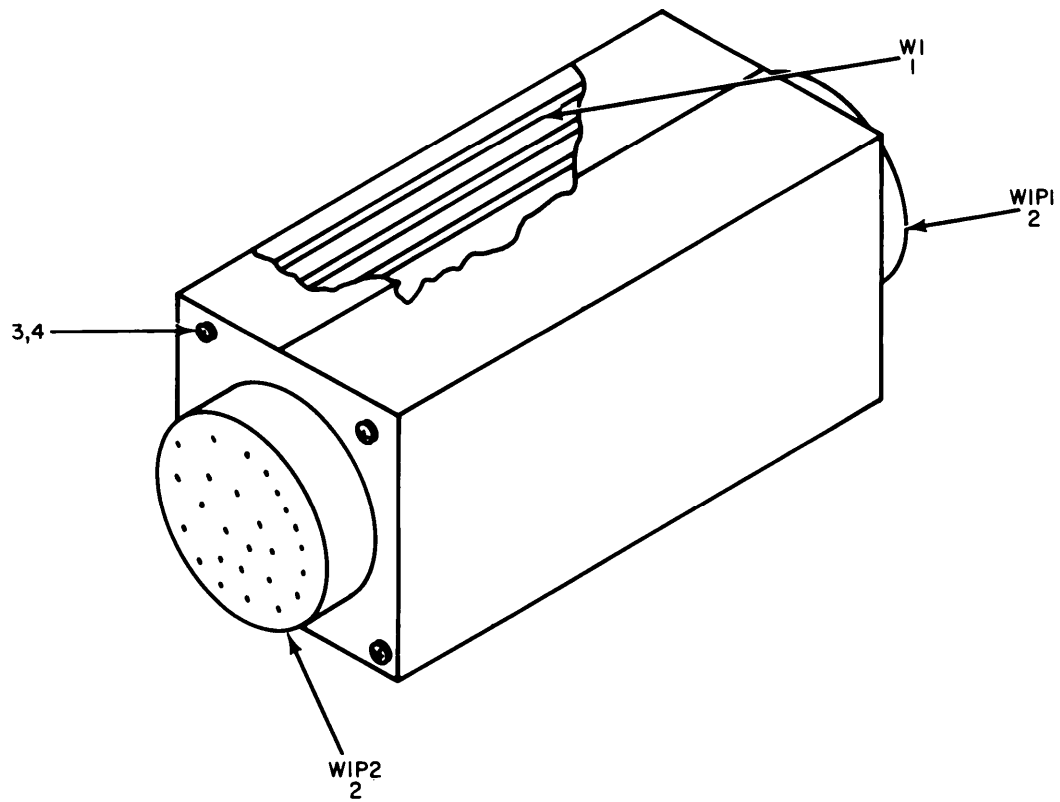

NOTE: FOR COMPLETE REFERENCE DESIGNATION PREFIX WITH A3.

Figure 21. Adapter, Connector U-334/ARC-51X.

SECTION II

(1)	(2)	(3)	(4)	(5)	(6)	(7)	(8)	
ILLUSTRATION								
(A)	(B)	NATIONAL		DESCRIPTION		QTY		
FIG	ITEM	SMR	STOCK	PART		USABLE	ON CODE	
NO	NO	CODE	NUMBER	NUMBER	FSCM		U/M	
							UNIT	
GROUP 05 ADAPTER,CONNECTOR U-334/ARC-51X								
21	1	XDOOO		761-7019-001	13499	WIRING HARNESS	EA	1
21	2	PAOZZ	5935-00-835-3031	MS3112E16-26P	96906	CONNECTOR,RECEPTACL	EA	2
21	3	PAOZZ	5305-00-054-5647	MS51957-13	96906	SCREW,MACHINE	EA	8
21	4	PAOZZ	5310-00-058-2949	310-0278-000	70318	WASHER,LOCK	EA	8

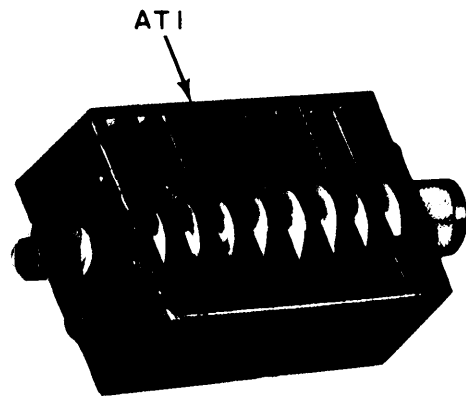

NOTE FOR COMPLETE REFERENCE
DESIGNATION PREFIX WITH AII

EL4HK034

Figure 22. Dummy Load, Electrical DA-397/ARC-51X.

SECTION II

(1)	(2)	(3)	(4)	(5)	(6)	(7)	(8)	
ILLUSTRATION							QTY	
(A)	(B)		NATIONAL		DESCRIPTION		INC	
FIG	ITEM	SMR	STOCK	PART			IN	
NO	NO	CODE	NUMBER	NUMBER	FSCM	USABLE ON CODE	U/M	UNIT

GROUP 06 DUMMY LOAD, ELECTRICAL

DA-397/ARC-51X

22	1	PAOZZ	6625-00-738-5991	713-0055-010	13499	DUMMY LOAD, ELEC	EA	1
----	---	-------	------------------	--------------	-------	------------------	----	---

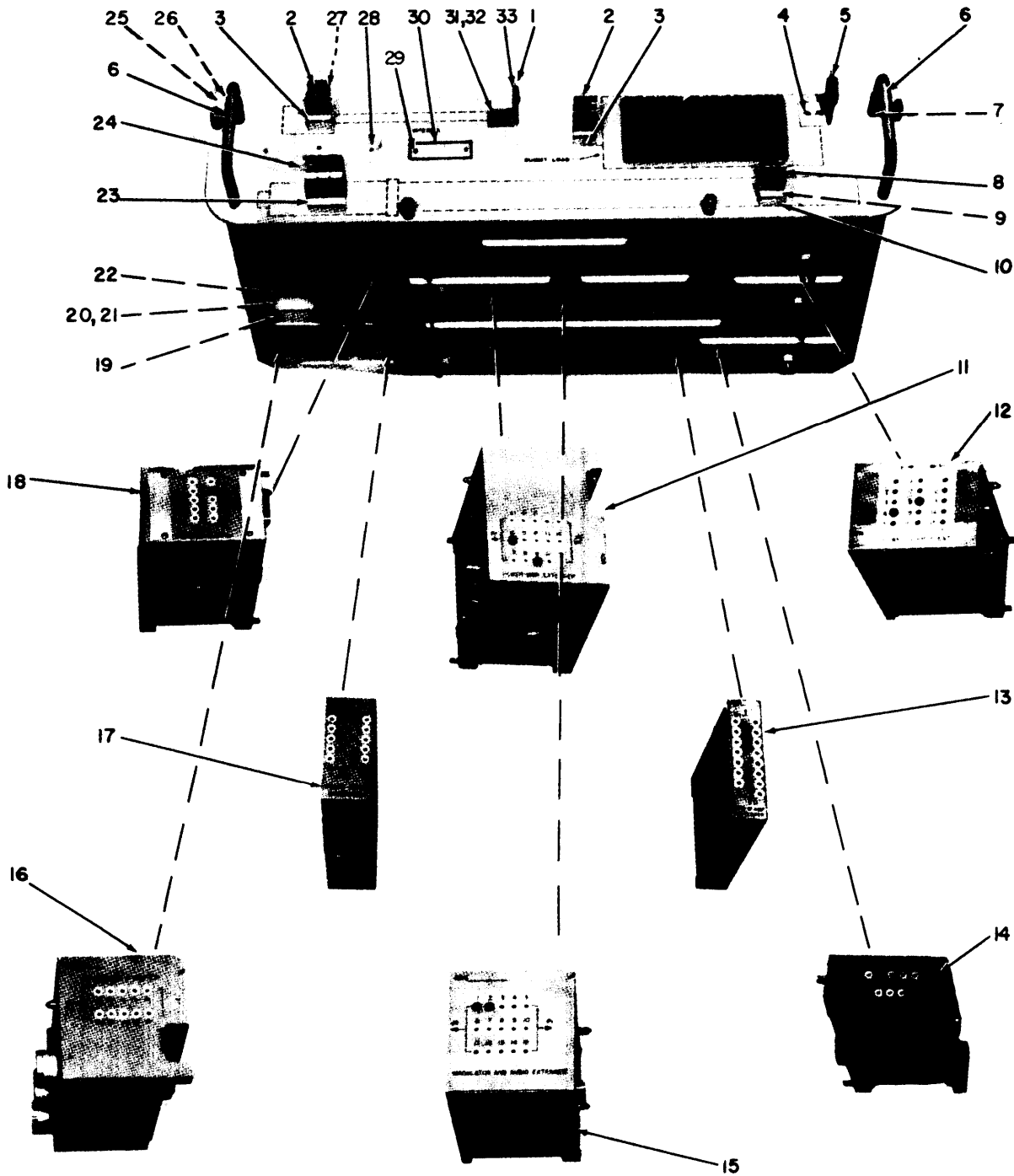

EL4HK035

Figure 23. Mounting Tray, Module Extender MT-3372/ARC-51X.

SECTION II

(1) ILLUSTRATION (A) FIG NO	(2) (B) ITEM NO	(3) SMR CODE	(4) NATIONAL STOCK NUMBER	(5) PART NUMBER	(6) FSCM DESCRIPTION	(7) USABLE ON CODE U/M	(8) QTY INC IN UNIT
GROUP 07 MOUNTING TRAY,MODULE EXTENDER							
MT-3372/ARC-51X							
23	1	XDOZZ		756-9024-001	13499 BRACKET,ANTENNA	EA	1
23	2	PAOZZ	5340-00-946-9442	6018-124CN	91506 CLIP,SPRING TENSION	EA	1
23	3	XDOZZ		761-7026-001	13499 SPACER,PLATE	EA	1
23	4	PAOZZ	5305-00-763-7822	MS51959-14	96906 SCREW,MACHINE	EA	13
23	5	XDOZZ		761-7025-001	13499 BRACKET,FXTR MT USED ONLY ONMK731ARC51X	EA	1
23	6	XDOZZ		NP9	08730 HANDLE,BOW	EA	2
23	7	PAOZZ	5305-00-071-1321	MS51960-64	96906 SCREW,MACHINE	EA	4
23	8	PAOZZ	5340-00-930-0107	6019-41CN	91506 CLIP,SPRING TENSION	EA	1
23	9	PAOZZ	5305-00-054-5648	MS51957-14	96906 SCREW,MACHINE	EA	1
23	10	XDOZZ		756-9021-001	13499 SPACER,PLATE	EA	1
23	11	PAOOO	6625-00-738-5982	MX4911ARC51X	80058 ADAPTER,TEST	EA	1
23	12	PAOOO	6625-00-738-5980	MX4909ARC51X	80058 ADAPTER,TEST	EA	1
23	13	PAOOO	6625-00-738-5979	MX4908ARC51X	80058 ADAPTER,TEST	EA	1
23	14	PAOOO	6625-00-738-5977	MX4906ARC51X	80058 ADAPTER,TEST	EA	1
23	15	PAOOO	6625-00-738-5975	MX4913ARC51X	80058 ADAPTER,TEST	EA	1
23	16	PAOOO	6625-00-738-5978	MX4907ARC51X	80058 EXTENDER,MODULE	EA	1
23	17	PAOOO	6625-00-738-5983	MX4912ARC51X	80058 ADAPTER,TEST	EA	1
23	18	PAOOO	6625-00-738-5981	MX4910ARC51X	80058 EXTENDER,MODULE	EA	1
23	19	XDOZZ		756-9032-001	13499 BRACKET,SPARE P	EA	1
23	20	PAOZZ	5310-00-208-3786	P313-0132-00	77250 NUT,PLAIN,HEXAGON	EA	12
23	21	PAOZZ	5305-00-054-5653	MS51957-19	96906 SCREW,MACHINE	EA	4
23	22	XDOZZ		541-5987-002	13499 SPACER,SLEEVE	EA	4
23	23	XDOZZ		756-9020-001	13499 SPACER,PLATE	EA	1
23	24	PAOZZ	5340-00-930-0835	6020-11CN	91506 CLIP,SPRING TENSION	EA	1
23	25	PAOZZ	5340-00-722-8713	540-9168-003	13499 POST,ELECTRICAL-MEC	EA	2
23	26	PAOZZ	5305-00-777-6039	MS51959-12	96906 SCREW,MACHINE	EA	4
23	27	PAOZZ	5305-00-054-5650	MS51957-16	96906 SCREW,MACHINE	EA	2
23	28	PAOZZ	5305-00-054-5649	MS51957-15	96906 SCREW,MACHINE	EA	3
23	29	PAOZZ	5305-00-054-5635	MS51957-1	96906 SCREW,MACHINE	EA	2
23	30	XDOZZ		767-0764-008	13499 PLATE,IDENT	EA	1
23	31	PAOZZ	5305-00-054-5646	MS51957-12	96906 SCREW,MACHINE	EA	2
23	32	PAOZZ	5310-00-933-8118	MS35338-135	96906 WASHER,LOCK	EA	14
23	33	PAOZZ	5325-00-174-5317	MS35489-4	96906 GROMMET,RUBBER	EA	1

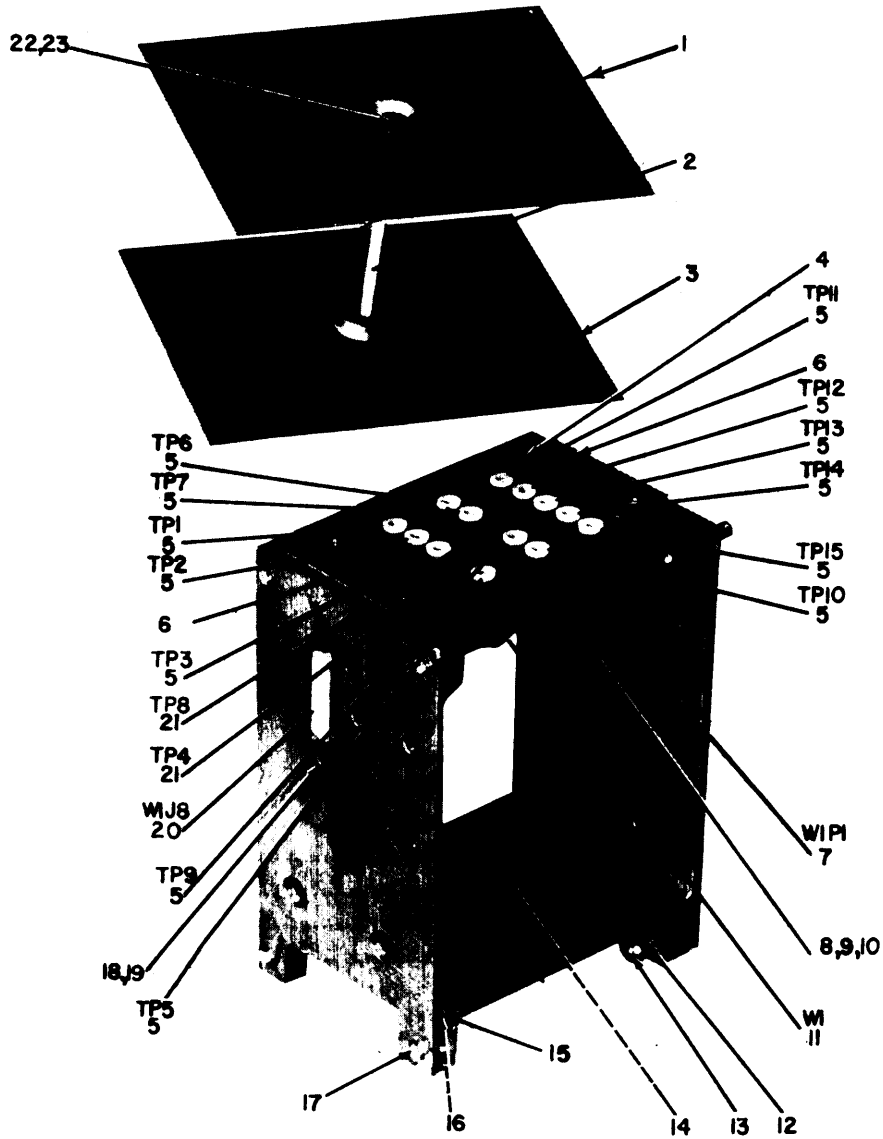

NOTE: FOR COMPLETE REFERENCE DESIGNATION
PREFIX WITH MP8

EL4HK036

Figure 24. Extender, Module MX-4913/ARC-51X.

SECTION II

(1) ILLUSTRATION (A) FIG NO	(2) (B) ITEM NO	(3) SMR CODE	(4) NATIONAL STOCK NUMBER	(5) PART NUMBER	(6) FSCM	(7) DESCRIPTION USABLE ON CODE	(8) QTY INC IN UNIT
GROUP 0701 EXTENDER,MODULE MX-4913/ARC-51X							
24	1	XDOZZ		756-8952-002	13499	COVER,MDL EXTEN	EA 1
24	2	XDOZZ		756-8969-001	13499	POST,ELMCH	EA 1
24	3	XDOZZ		756-8952-001	13499	COVER,MDL EXTEN	EA 1
24	4	PAOZZ	5305-00-054-5635	MS51957-1	96906	SCREW,MACHINE	EA 6
24	5	PAOZZ	5935-00-954-4470	SKT41WHITE	98291	JACK,TIP	EA 13
24	6	XDOZZ		756-8970-001	13499	PLATE,ACCESS CO	EA 2
24	7	PAOZZ	5935-00-057-2690	DA15P	71468	CONNECTOR,RECEPTACL	EA 1
24	8	PAOZZ	5305-00-763-3356	MS51959-5	96906	SCREW,MACHINE	EA 2
24	9	PAOZZ	5310-00-928-2690	310-0070-000	79807	WASHER,LOCK	EA 4
24	10	PAOZZ	5310-00-938-2013	MS35649-24	96906	NUT,PLAIN,HEXAGON	EA 4
24	11	XDOOO		761-7018-001	13499	WIRING HARNESS	EA 1
24	12	PAOZZ	5365-00-695-2558	340-0642-00	91314	RING,RETAINING	EA 4
24	13	PAOZZ	5305-00-909-1949	756-8924-001	13499	SCREW,CAP, SOCKET HE	EA 4
24	14	XDOZZ		767-0747-010	13499	PLATE,IDENT	EA 1
24	15	XDOZZ		756-8927-002	13499	PIN,LOCATING	EA 2
24	16	PAOZZ	5315-00-291-5471	MS16562-189	96906	PIN,SPRING	EA 4
24	17	PAOZZ	5340-00-479-9197	MS122119	96906	INSERT,SCREW THREAD	EA 4
24	18	PAOZZ	5310-00-907-0959	310-6320-000	79807	WASHER,FLAT	EA 2
24	19	PAOZZ	5305-00-727-8833	MS51959-3	96906	SCREW,MACHINE	EA 2
24	20	PAOZZ	5935-00-993-2181	DAF15S	71468	CONNECTOR,RECEPTACL	EA 1
24	21	PAOZZ	5935-00-061-1363	SKT41RED	98291	JACK,TIP	EA 2
24	22	PAOZZ	5305-00-054-6651	MS51957-27	96906	SCREW,MACHINE	EA 2
24	23	PAOZZ	5310-00-929-6395	310-0071-000	79807	WASHER,LOCK	EA 2

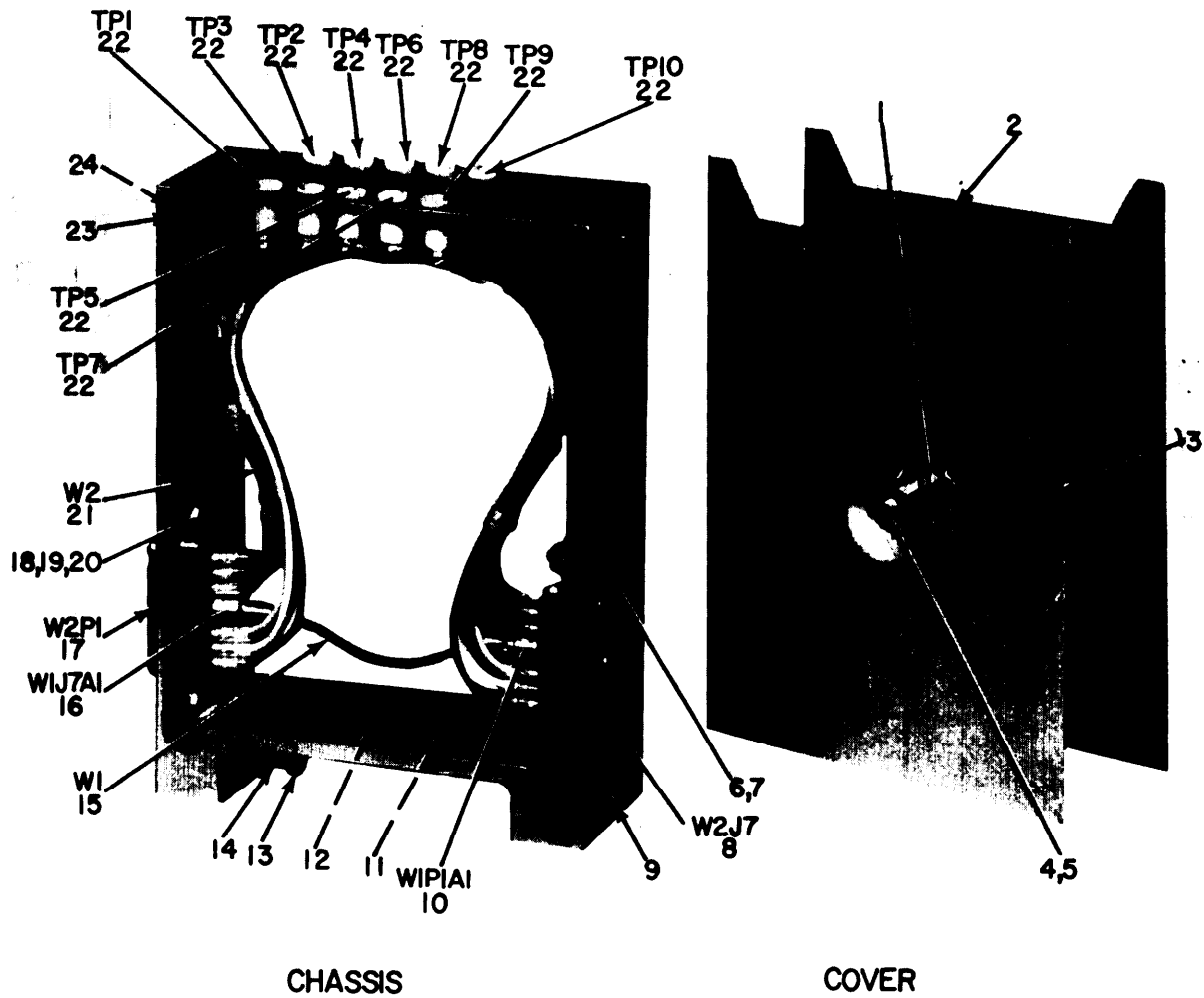

EL4HK037

Figure 25. Extender, Module MX-4912/ARC-51X.

SECTION II

(1) ILLUSTRATION (A) FIG NO	(2) (B) ITEM NO	(3) SMR CODE	(4) NATIONAL STOCK NUMBER	(5) PART NUMBER	(6) DESCRIPTION FSCM	(7) USABLE ON CODE	(8) QTY INC IN UNIT
GROUP 0702 EXTENDER,MODULE MX-4912/ARC-51X							
25	1	XDOZZ		756-8978-001	13499 POST,ELMCH	EA	1
25	2	XDOZZ		756-8985-001	13499 COVER,MDL EXTEN	EA	1
25	3	XDOZZ		756-8982-002	13499 COVER,MDL EXTEN	EA	1
25	4	PAOZZ	5305-00-054-6651	MS51957-27	96906 SCREW,MACHINE	EA	2
25	5	PAOZZ	5310-00-929-6395	310-0071-000	79807 WASHER,LOCK	EA	2
25	6	PAOZZ	5305-00-763-3356	MS51959-5	96906 SCREW,MACHINE	EA	2
25	7	PAOZZ	5310-00-928-2690	310-0070-000	79807 WASHER,LOCK	EA	4
25	8	PAOZZ	5935-00-059-2640	DAMF11W1S	71468 CONNECTOR,RECEPTACL	EA	1
25	9	PAOZZ	5340-00-479-9197	MS122119	96906 INSERT,SCREW THREAD	EA	2
25	10	PAOZZ	5935-00-885-6505	DM53740-5000	71468 CONNECTOR,PLUG,ELEC	EA	1
25	11	PAOZZ	5305-00-054-5635	MS51957-1	96906 SCREW,MACHINE	EA	2
25	12	XDOZZ		767-0748-010	13499 PLATE,IDENT	EA	1
25	13	PAOZZ	5305-00-909-1949	756-8924-001	13499 SCREW,CAP,SOCKET HE	EA	2
25	14	PAOZZ	5365-00-695-2558	340-0642-00	91314 RING,RETAINING	EA	2
25	15	XDOOO		761-7003-002	13499 CABLE ASSEMBLY	EA	1
25	16	PAOZZ	5935-00-080-0268	DM53742-5000	71468 CONNECTOR,PLUG,ELEC	EA	1
25	17	PAOZZ	5935-00-901-5850	DAM11W1P	71468 CONNECTOR,RECEPTACL	EA	1
25	18	PAOZZ	5310-00-938-2013	MS35649-24	96906 NUT,PLAIN,HEXAGON	EA	4
25	19	PAOZZ	5305-00-727-8833	MS51959-3	96906 SCREW,MACHINE	EA	2
25	20	PAOZZ	5310-00-907-0959	310-6320-000	79807 WASHER,FLAT	EA	2
25	21	XDOOO		761-7016-001	13499 WIRING HARNESS	EA	1
25	22	PAOZZ	5935-00-954-4470	SKT41WHITE	98291 JACK,TIP9	EA	10
25	23	XDOZZ		756-8927-002	13499 PIN,LOCATING	EA	2
25	24	PAOZZ	5315-00-291-5471	MS16562-189	96906 PION,SPRING	EA	4

SECTION II

(1) ILLUSTRATION (A) FIG NO	(2) (B) ITEM NO	(3) SMR CODE	(4) NATIONAL STOCK NUMBER	(5) PART NUMBER	(6) DESCRIPTION FSCM	(7) USABLE ON CODE	(8) QTY INC IN UNIT
GROUP 0703 EXTENDER,MODULE MX-4911/ARC-51X							
26	1	PAOZZ	5935-00-954-4470	SKT41WHITE	98291 JACK, TIP	EA	13
26	2	PAOZZ	5935-00-061-1363	SKT41RED	98291 JACK, TIP	EA	2
26	3	XDOZZ		756-8922-001	13499 PLATE, RING, SFT	EA	1
26	4	PAOZZ	5305-00-054-5646	MS51957-12	96906 SCREW, MACHINE	EA	4
26	5	PAOZZ	5310-00-058-2949	310-0278-000	70318 WASHER, LOCK	EA	4
26	6	XDOZZ		756-8942-001	13499 COVER, MDL EXTEN	EA	1
26	7	PAOZZ	5935-00-881-9480	51-258	98278 CONNECTOR, RECEPTACL	EA	1
26	8	XDOZZ		756-8936-001	13499 BUSHING, MACHINE	EA	1
26	9	XDOZZ		53-315	98278 CONNECTOR, GRD, S	EA	2
26	10	XDOZZ		756-8937-001	13499 WASHER, FLAT	EA	1
26	11	PAOZZ	5305-00-054-6651	MS51957-27	96906 SCREW, MACHINE	EA	2
26	12	PAOZZ	5310-00-929-6395	310-0071-000	79807 WASHER, LOCK	EA	2
26	13	XDOZZ		756-8942-002	13499 COVER, MDL EXTEN	EA	1
26	14	XDOZZ		756-8928-001	13499 POST, ELMCH	EA	1
26	15	PAOZZ	5935-00-993-2181	DAF15S	71468 CONNECTOR, RECEPTACL	EA	1
26	16	PAOZZ	5310-00-938-2013	MS35649-24	96906 NUT, PLAIN, HEXAGON	EA	8
26	17	PAOZZ	5305-00-763-3356	MS51959-5	96906 SCREW, MACHINE	EA	4
26	18	XDOZZ		310000070000	79807 WASHER, LOCK	EA	8
26	19	PAOZZ	5935-00-089-6921	DAMF3W3S	71468 CONNECTOR, RECEPTACL	EA	1
26	20	PAOZZ	5935-00-080-0268	DM53742-5000	71468 CONNECTOR, PLUG, ELEC	EA	3
26	21	XDOOO		761-7003-002	13499 CABLE ASSEMBLY	EA	3
26	22	XDOZZ		756-8927-001	13499 PIN, LOCATING	EA	2
26	23	PAOZZ	5315-00-291-5471	MS16562-189	96906 PIN, SPRING	EA	4
26	24	XDOZZ		767-0758-010	13499 PLATE, IDENT	EA	1
26	25	PAOZZ	5305-00-054-5635	MS51957-1	96906 SCREW, MACHINE	EA	2
26	26	PAOZZ	5935-00-885-6505	DM53740-5000	71468 CONNECTOR, PLUG, ELEC	EA	3
26	27	PAOZZ	5305-00-909-1949	756-8924-001	13499 SCREW, CAP, SOCKET HE	EA	4
26	28	PAOZZ	5340-00-479-9197	MS122119	96906 INSERT, SCREW THREAD	EA	4
26	29	PAOZZ	5365-00-695-2558	340-0642-00	91314 RING, RETAINING	EA	4
26	30	PAOZZ	5305-00-727-8833	MS51959-3	96906 SCREW, MACHINE	EA	4
26	31	PAOZZ	5310-00-907-0959	310-6320-000	79807 WASHER, FLAT	EA	4
26	2	PAOZZ	5935-00-089-6505	DAM3W3P	71468 CONNECTOR BODY, RECE	EA	1
26	33	PAOZZ	5935-00-057-2690	DA15P	71468 CONNECTOR, RECEPTACL	EA	1
26	34	XDOOO		761-7014-001	13499 WIRING HARNESS	EA	1
26	35	PAOZZ	5935-00-088-9619	052-0512	98278 CONNECTOR, RECEPTACL	EA	1
26	36	PAOZZ	6145-00-080-6517	RG303U	81349 CABLE, RF	FT	1
26	37	PAOZZ	6625-00-058-3841	761-7006-002	13499 SHAFT AND PIN ASSEM	EA	1
26	38	PAOZZ	5821-00-021-4832	549-3856-002	13499 INSERT, FLEXIBLE COU	EA	1
26	39	PAOZZ	6625-00-058-3811	756-8926-001	13499 RETAINER, COUPLING	EA	1

SECTION II

(1)	(2)	(3)	(4)	(5)	(6)	(7)	(8)	
ILLUSTRATION							QTY	
(A)	(B)	NATIONAL			DESCRIPTION		INC	
FIG	ITEM	SMR	STOCK	PART			IN	
NO	NO	CODE	NUMBER	NUMBER	FSCM	USABLE ON CODE	U/M	UNIT
26	40	PAOZZ	5330-00-824-9130	213-141216-00-2303	78189	PACKING PREFORMED	EA	1

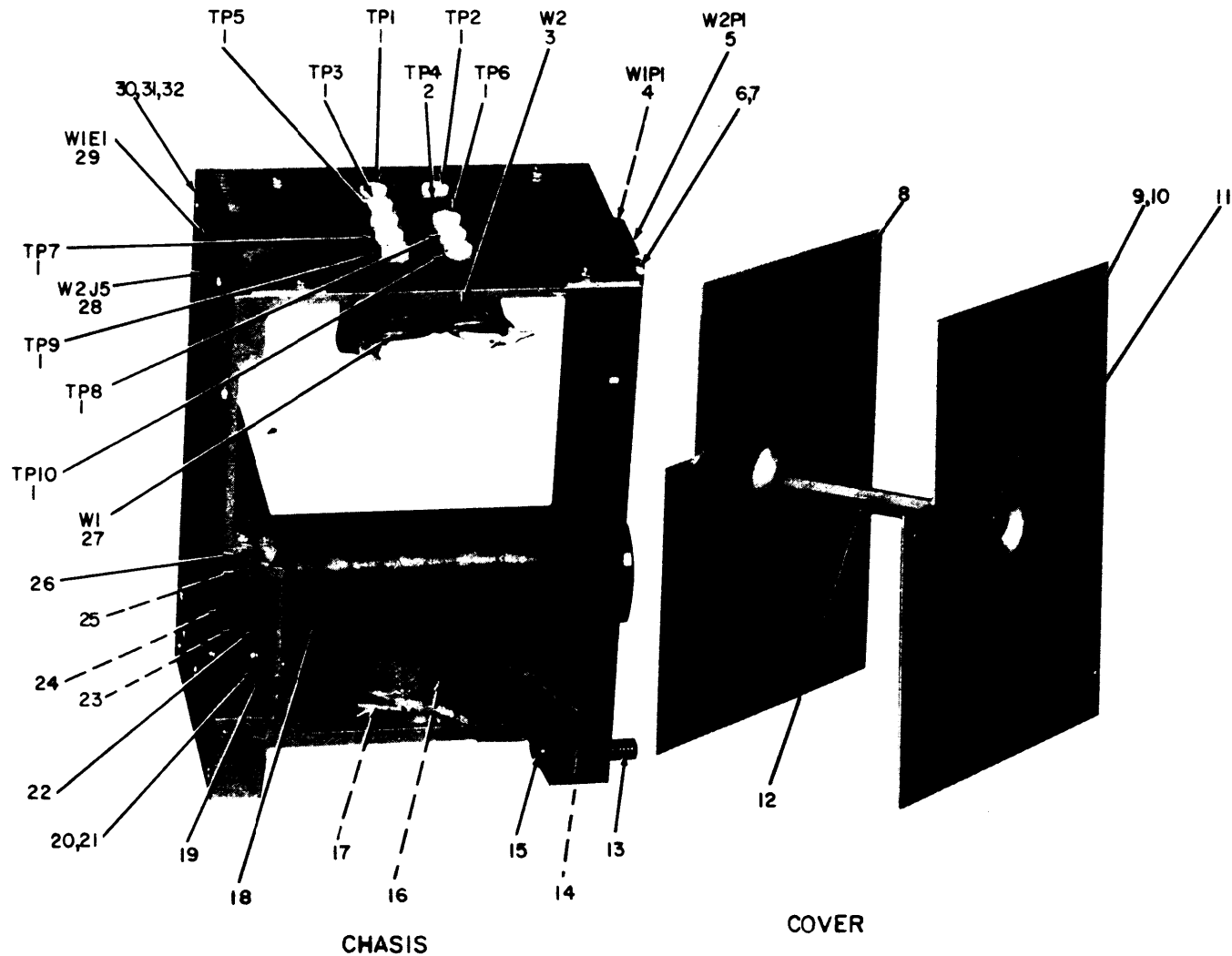

NOTE: FOR COMPLETE REFERENCE DESIGNATION PREFIX WITH MP5

EL4HK039

Figure 27. Extender, Module MX-4910/ARC-51X.

SECTION II

(1) ILLUSTRATION (A) FIG NO	(2) (B) ITEM NO	(3) SMR CODE	(4) NATIONAL STOCK NUMBER	(5) PART NUMBER	(6) DESCRIPTION FSCM	(7) USABLE ON CODE	(8) QTY INC IN UNIT
GROUP 0704 EXTENDER,MODULE MX-4910/ARC-51X							
27	1	PAOZZ	5935-00-954-4470	SKT41WHITE	98291 JACK,TIP	EA	9
27	2	PAOZZ	5935-00-061-1363	SKT41RED	98291 JACK,TIP	EA	1
27	3	XDOOO		761-7012-001	13499 WIRING HARNESS	EA	1
27	4	PAOZZ	5935-00-885-6505	DM53740-5000	71468 CONNECTOR,PLUG,ELEC	EA	1
27	5	PAOZZ	5935-00-901-5850	DAM11W1P	71468 CONNECTOR,RECEPTACL	EA	1
27	6	PAOZZ	5310-00-938-2013	MS35649-24	96906 NUT,PLAIN,HEXAGON	EA	4
27	7	PAOZZ	5305-00-727-8833	MS51959-3	96906 SCREW,MACHINE	EA	2
27	8	XDOZZ		756-8916-001	13499 COVER,MDL EXTEN	EA	1
27	9	PAOZZ	5305-00-054-6651	MS51957-27	96906 SCREW,MACHINE	EA	2
27	10	PAOZZ	5310-00-929-6395	310-0071-000	79807 WASHER,LOCK	EA	2
27	11	XDOZZ		756-8916-002	13499 COVER,MDL EXTEN	EA	1
27	12	XDOZZ		756-8911-001	13499 POST,ELECTRICAL-MEC	EA	1
27	13	PAOZZ	5365-00-695-2558	340-0642-00	91314 RING,RETAINING	EA	3
27	14	PAOZZ	5340-00-479-9197	MS122119	96906 INSERT,SCREW THREAD	EA	3
27	15	PAOZZ	5305-00-909-1949	756-8924-001	13499 SCREW,CAP, SOCKET HE	EA	3
27	16	XDOZZ		767-0759-010	13499 PLATE,IDENT	EA	1
27	17	PAOZZ	5305-00-054-5635	MS51957-1	96906 SCREW,MACHINE	EA	6
27	18	PAOZZ	6625-00-058-3841	761-7006-002	13499 SHAFT AND PIN ASSEM	EA	1
27	19	XDOZZ		756-8922-001	13499 PLATE,RETAINING	EA	1
27	20	PAOZZ	5305-00-054-5646	MS51957-12	96906 SCREW,MACHINE	EA	4
27	21	PAOZZ	5310-00-058-2949	310-0278-000	70318 WASHER,LOCK	EA	4
27	22	PAOZZ	6625-00-058-3811	756-8926-001	13499 RETAINER,COUPLING	EA	1
27	23	PAOZZ	5821-00-021-4832	549-3856-002	13499 INSERT,FLEXIBLE COU	EA	1
27	24	PAOZZ	5330-00-824-9130	213-141216-00-2303	78189 PACKING PREFORMED	EA	1
27	25	PAOZZ	5315-00-291-5471	MS16562-189	96906 PIN,SPRING	EA	4
27	26	XDOZZ		756-8927-001	13499 PIN,LOCATING	EA	2
27	27	XDOOO		761-7003-002	13499 CABLE ASSEMBLY	EA	1
27	28	PAOZZ	5935-00-059-2640	DAMF11W1S	71468 CONNECTOR,RECEPTACL	EA	1
27	29	PAOZZ	5935-00-080-0268	DM53742-5000	71468 CONNECTOR,PLUG,ELEC	EA	1
27	30	PAOZZ	5305-00-763-3356	MS51959-5	96906 SCREW,MACHINE	EA	2
27	31	PAOZZ	5310-00-907-0959	310-6320-000	79807 WASHER,FLAT	EA	2
27	32	PAOZZ	5310-00-928-2690	310-0070-000	79807 WASHER,LOCK	EA	4

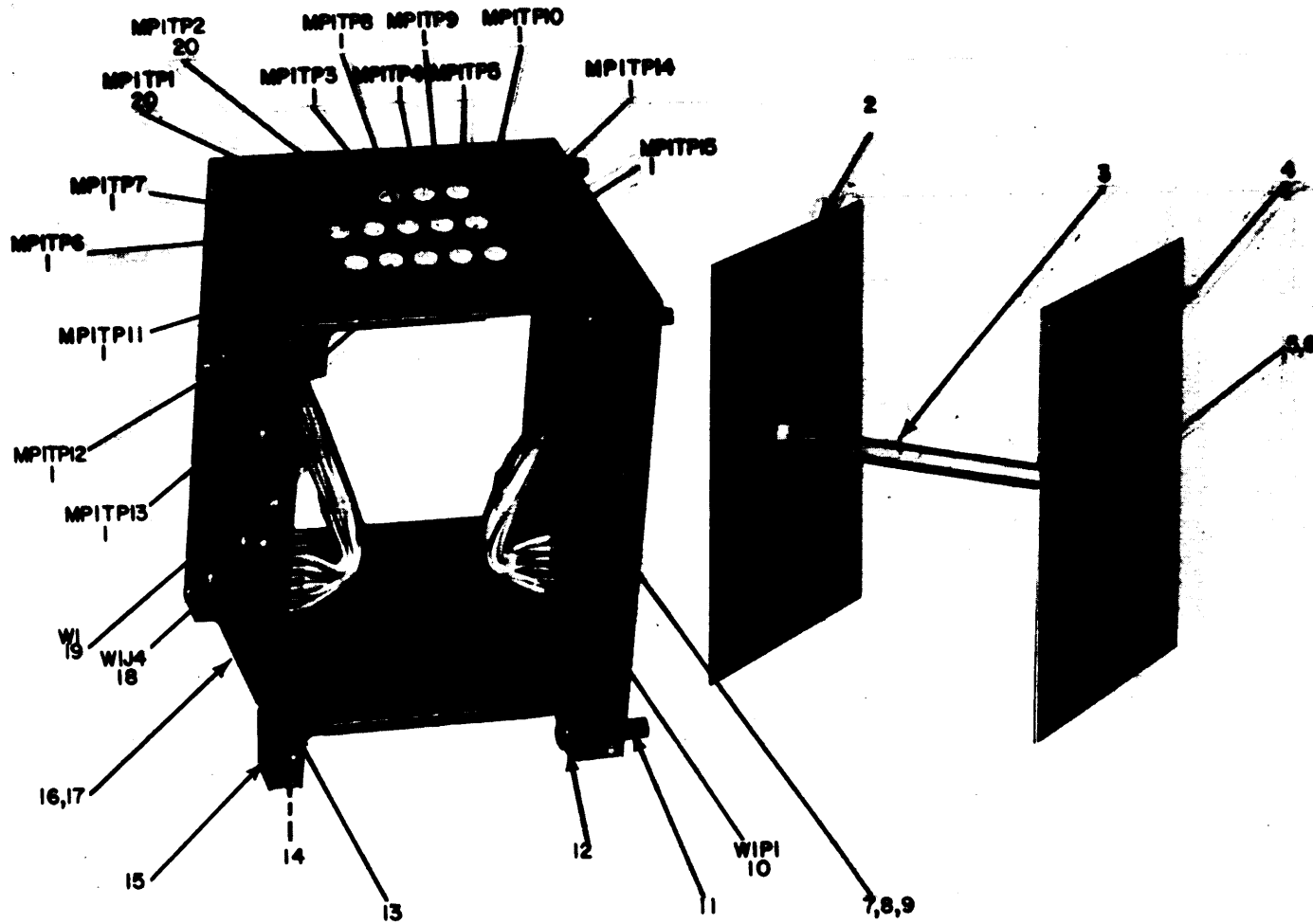

NOTE: FOR COMPLETE REFERENCE DESIGNATION PREFIX WITH MP4

EL4HK040

Figure 28. Extender, Module MX-4909/ARC-51X.

SECTION II

(1) ILLUSTRATION (A) FIG NO	(2) (B) ITEM NO	(3) NATIONAL STOCK NUMBER	(4) PART NUMBER	(5) FSCM	(6) DESCRIPTION	(7) USABLE ON CODE	(8) QTY INC IN UNIT
GROUP 0705 EXTENDER,MODULE MX-4909/ARC-51X							
28	1	PAOZZ 5935-00-954-4470	SKT41WHITE	98291	JACK,TIP	EA	13
28	2	XDOZZ	756-8952-001	13499	COVER,MDL EXTEN	EA	1
28	3	XDOZZ	756-8958-001	13499	POST,ELECTRICAL-MEC	EA	1
28	4	XDOZZ	756-8952-002	13499	COVER,MDL EXTEN	EA	1
28	5	PAOZZ 5305-00-054-6651	MS51957-27	96906	SCREW,MACHINE	EA	2
28	6	PAOZZ 5310-00-929-6395	310-0071-000	79807	WASHER,LOCK	EA	2
28	7	PAOZZ 5305-00-763-3356	MS51959-5	96906	SCREW,MACHINE	EA	2
28	8	PAOZZ 5310-00-907-0959	310-6320-000	79807	WASHER,FLAT	EA	2
28	9	PAOZZ 5310-00-928-2690	310-0070-000	79807	WASHER,LOCK	EA	2
28	10	PAOZZ 5935-00-057-2690	DA15P	71468	CONNECTOR,RECEPTACL	EA	1
28	11	PAOZZ 5365-00-695-2558	340-0642-00	91314	RING,RETAINING	EA	4
28	12	PAOZZ 5305-00-909-1949	756-8924-001	13499	SCREW,CAP,SOCKET HE	EA	4
28	13	XDOZZ	756-8927-002	13499	PIN,LOCATING	EA	2
28	14	PAOZZ 5315-00-291-5471	MS16562-189	96906	PIN,SPRING	EA	4
28	15	PAOZZ 5340-00-479-9197	MS122119	96906	INSERT,SCREW THREAD	EA	4
28	16	PAOZZ 5310-00-938-2013	MS35649-24	96906	NUT,PLAIN,HEXAGON	EA	4
28	17	PAOZZ 5305-00-727-8833	MS51959-3	96906	SCREW,MACHINE	EA	2
28	18	PAOZZ 5935-00-993-2181	DAF15S	71468	CONNECTOR,RECEPTACL	EA	1
28	19	XDOOO	761-7010-001	13499	WIRING HARNESS	EA	1
28	20	PAOZZ 5935-00-061-1363	SKT41RED	98291	JACK,TIP	EA	2

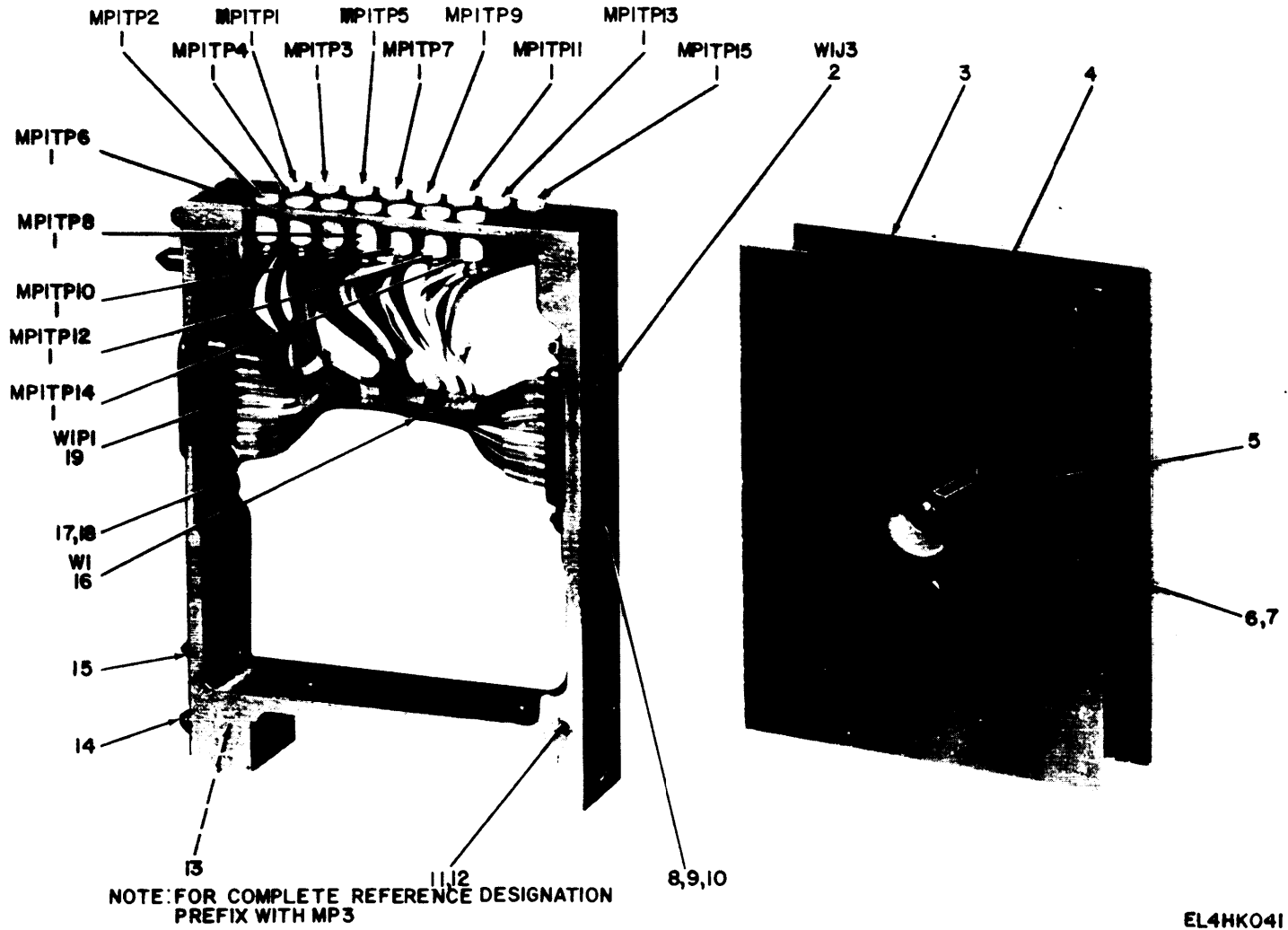
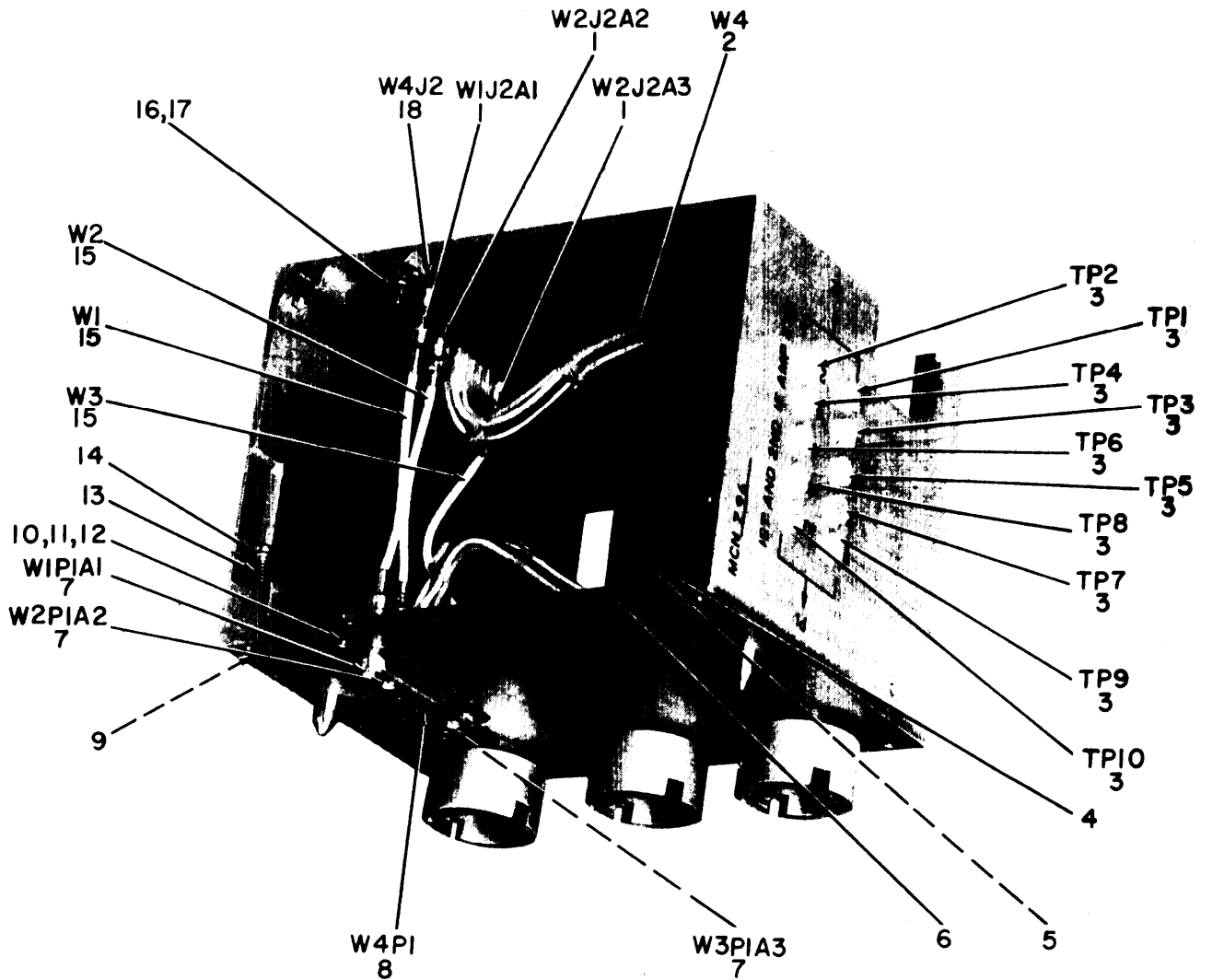

Figure 29. Extender, Module MX-4908/ARC-51X.

SECTION II

(1) ILLUSTRATION (A) FIG NO	(2) (B) ITEM NO	(3) NATIONAL STOCK NUMBER	(4) PART NUMBER	(5) FSCM	(6) DESCRIPTION	(7) USABLE ON CODE	(8) QTY INC IN UNIT
GROUP 0706 EXTENDER,MODULE MX-4908/ARC-51X							
29	1	PAOZZ 5935-00-954-4470	SKT41WHITE	98291	JACK,TIP	EA	15
29	2	PAOZZ 5935-00-993-2181	DAF15S	71468	CONNECTOR,RECEPTACL	EA	1
29	3	XDOZZ	756-8905-001	13499	COVER,MDL EXTEN	EA	1
29	4	XDOZZ	756-8905-002	13499	COVER,MDL EXTEN	EA	1
29	5	XDOZZ	756-8902-001	13499	POST,ELMCH	EA	1
29	6	PAOZZ 5305-00-054-6651	MS51957-27	96906	SCREW,MACHINE	EA	2
29	7	PAOZZ 5310-00-929-6395	310-0071-000	79807	WASHER,LOCK	EA	2
29	8	PAOZZ 5305-00-763-3356	MS51959-5	96906	SCREW,MACHINE	EA	2
29	9	PAOZZ 5310-00-907-0959	310-6320-000	79807	WASHER,FLAT	EA	2
29	10	PAOZZ 5310-00-928-2690	310-0070-000	79807	WASHER,LOCK	EA	4
29	11	XDOZZ	756-8927-002	13499	PIN,LOCATING	EA	2
29	12	PAOZZ 5315-00-291-5471	MS16562-189	96906	PIN,SPRING	EA	4
29	13	PAOZZ 5340-00-479-9197	MS122119	96906	INSERT,SCREW THREAD	EA	2
29	14	PAOZZ 5305-00-909-1949	756-8924-001	13499	SCREW,CAP,SOCKET HE	EA	1
29	15	PAOZZ 5365-00-695-2558	340-0642-00	91314	RING,RETAINING	EA	2
29	16	XDOOO	761-7008-001	13499	WIRING HARNESS	EA	1
29	17	PAOZZ 5310-00-938-2013	MS35649-24	96906	NUT,PLAIN,HEXAGON	EA	4
29	18	PAOZZ 5305-00-727-8833	MS51959-3	96906	SCREW,MACHINE	EA	2
29	19	PAOZZ 5935-00-057-2690	DA15P	71468	CONNECTOR,RECEPTACL	EA	1



TOP AND LEFT SIDE VIEW

NOTE: FOR COMPLETE REFERENCE DESIGNATION
PREFIX WITH MP2.

EL4HK042

Figure 30. Extender, Module MX-4907/ARC-51X (Sheet 1 of 2).

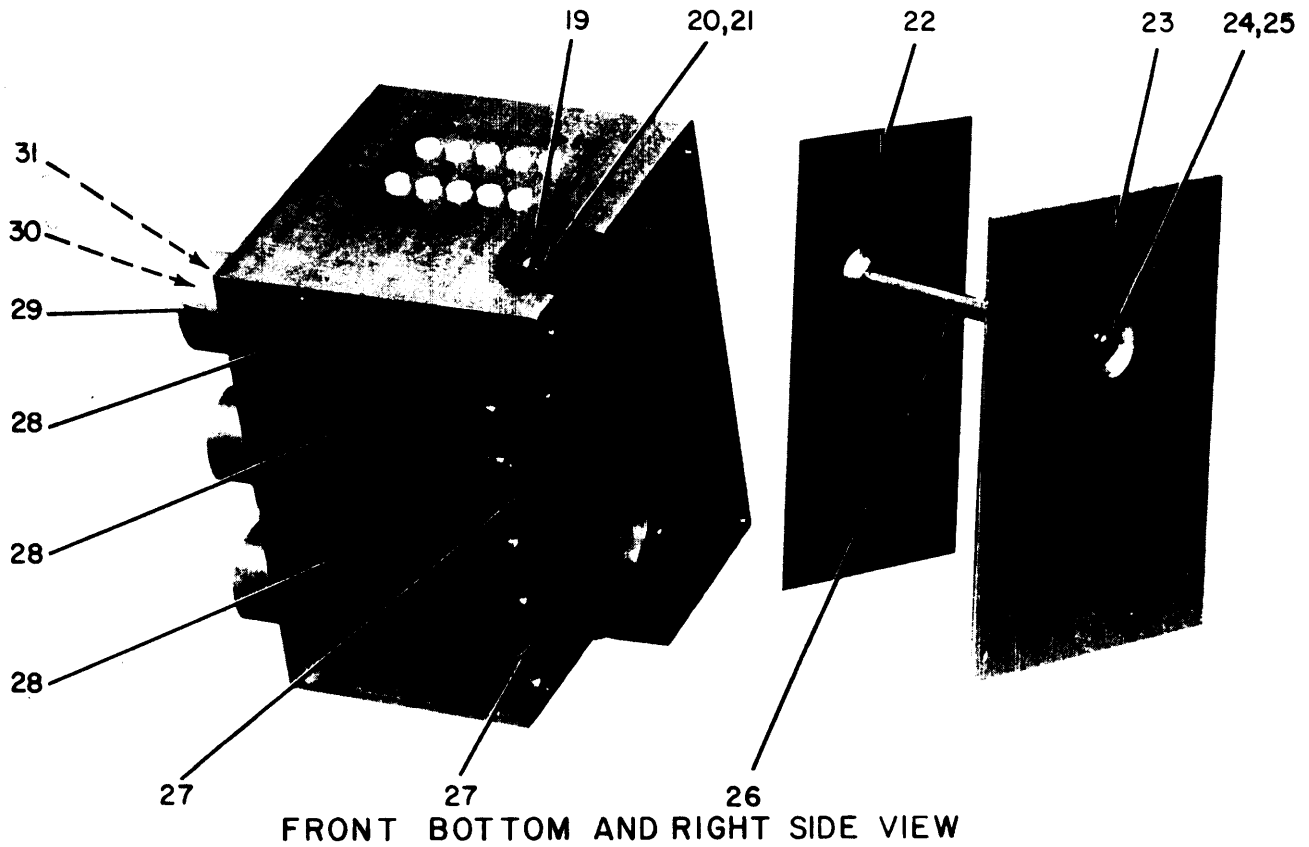

NOTE: FOR COMPLETE REFERENCE DESIGNATION
PREFIX WITH MP2

EL4HK043

Figure 30. Extender, Module MX-4907/ARC-51X (Sheet 2 of 2).

SECTION II

(1) ILLUSTRATION (A) FIG NO	(2) (B) ITEM NO	(3) SMR CODE	(4) NATIONAL STOCK NUMBER	(5) PART NUMBER	(6) FSCM	(7) DESCRIPTION USABLE ON CODE	(8) QTY INC IN UNIT
GROUP 0707 EXTENDER,MODULE MX-4907/ARC-51X							
30	1	PAOZZ	5935-00-080-0268	DM53742-5000	71468	CONNECTOR, PLUG, ELEC	EA 3
30	2	XDOOO		761-7005-001	13499	WIRING HARNESS	EA 1
30	3	PAOZZ	5935-00-954-4470	SKT41WHITE	98291	JACK, TIP	EA 10
30	4	XDOZZ		756-8927-001	13499	PIN, LOCATING	EA 2
30	5	PAOZZ	5315-00-291-5471	MS16562-189	96906	PIN, SPRING	EA 4
30	6	XDOZZ		756-8967-001	13499	CHASSIS, MDL EXT	EA 1
30	7	PAOZZ	5935-00-885-6505	DM53740-5000	714648	CONNECTOR, PLUG, ELEC	EA 3
30	8	PAOZZ	5935-00-811-1382	DBM13W3P	71468	CONNECTOR, RECEPTACL	EA 1
30	9	PAOZZ	5340-00-479-9197	MS122119	96906	INSERT, SCREW THREAD	EA 3
30	10	PAOZZ	5305-00-763-3356	MS51959-5	96906	SCREW, MACHINE	EA 2
30	11	PAOZZ	5310-00-907-0959	310-6320-000	79807	WASHER, FLAT	EA 2
30	12	PAOZZ	5310-00-928-2690	310-0070-000	79807	WASHER, LOCK	EA 4
30	13	PAOZZ	5365-00-695-2558	340-0642-00	91314	RING, RETAINING	EA 3
30	14	PAOZZ	5305-00-909-1949	756-8924-001	13499	SCREW, CAP, SOCKET HE	EA 3
30	15	XDOOO		761-7003-001	13499	CABLE ASSEMBLY	EA 3
30	16	PAOZZ	5310-00-938-2013	MS35649-24	96906	NUT, PLAIN, HEXAGON	EA 4
30	17	PAOZZ	5305-00-727-8833	MS51959-3	96906	SCREW, MACHINE	EA 2
30	18	PAOZZ	5935-00-089-1165	DBMF13W3S	71468	CONNECTOR, RECEPTACL	EA 1
30	19	XDOZZ		756-8922-001	13499	PLATE, RING SFT	EA 1
30	20	PAOZZ	5305-00-054-5646	MS51957-12	96906	SCREW, MACHINE	EA 10
30	21	PAOZZ	5310-00-058-2949	310-0278-000	70318	WASHER, LOCK	EA 10
30	22	XDOZZ		756-8964-001	13499	COVER, MDL EXTEN	EA 1
30	23	XDOZZ		756-8963-001	13499	COVER, MDL EXTEN	EA 1
30	24	PAOZZ	5305-00-054-6651	MS51957-27	96906	SCREW, MACHINE	EA 2
30	25	PAOZZ	5310-00-929-6395	310-0071-000	79807	WASHER, LOCK	EA 2
30	26	XDOZZ		756-8958-001	13499	POST, ELECTRICAL-MEC	EA 1
30	27	XDOZZ		756-8929-001	13499	PLATE, RETAINING	EA 2
30	28	PAOZZ	6625-00-058-3841	761-7006-002	13499	SHAFT AND PIN ASSEM	FT 3
30	29	PAOZZ	5821-00-043-1974	549-3662-002	13499	INSERT, FLEXIBLE COU	EA 3
30	30	PAOZZ	6625-00-058-3811	756-8926-001	13499	RETAINER, COUPLING	EA 3
30	31	PAOZZ	5330-00-824-9130	213-141216-00-2303	78189	PACKING PREFORMED	EA 3

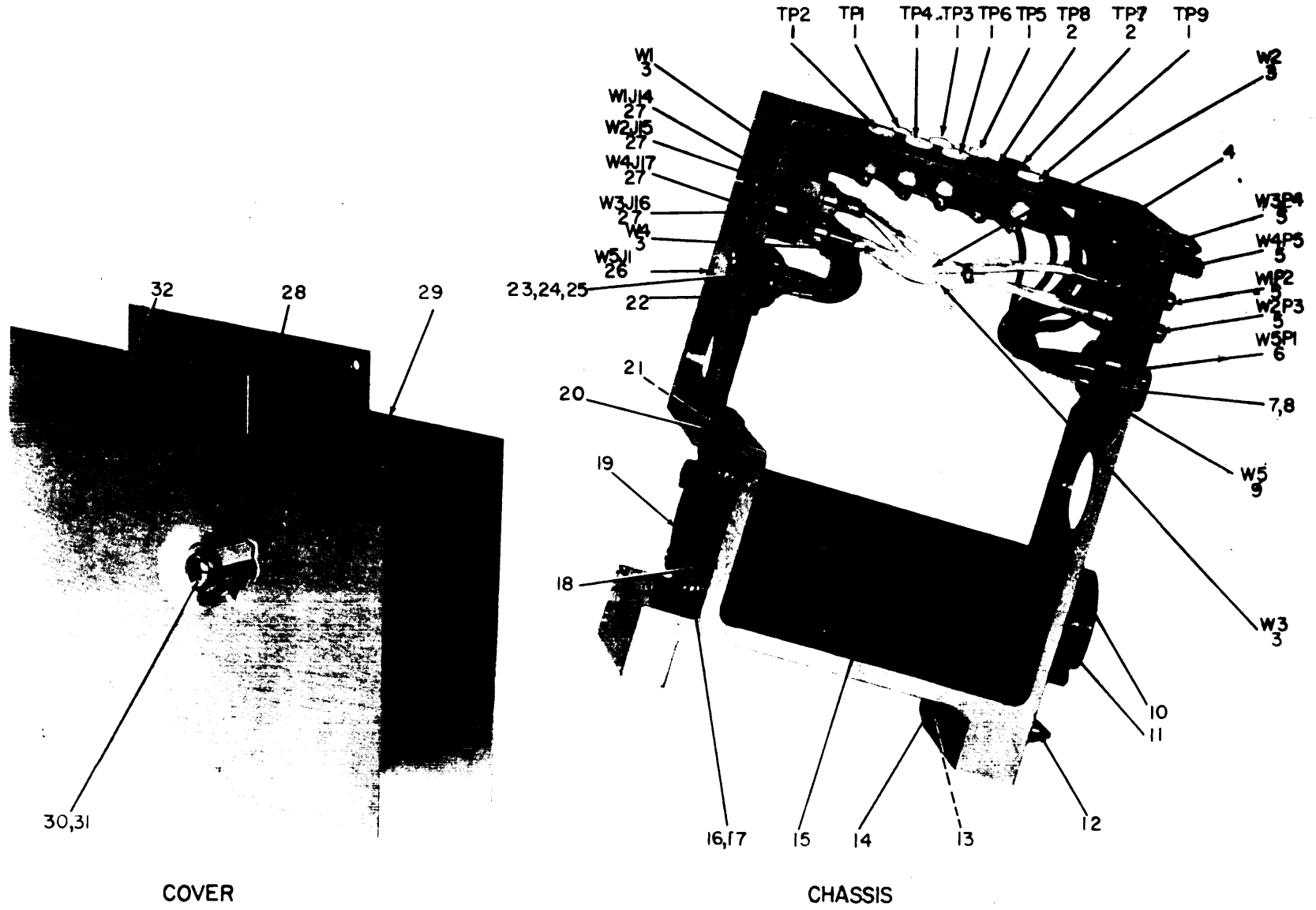

COVER

CHASSIS

NOTE: FOR COMPLETE REFERENCE DESIGNATION
PREFIX WITH MPI

EL4HK044

Figure 31. Extender, Module MX-4906/ARC-51X.

SECTION II

(1) ILLUSTRATION (A) FIG NO	(2) (B) ITEM NO	(3) SMR CODE	(4) NATIONAL STOCK NUMBER	(5) PART NUMBER	(6) FSCM	(7) DESCRIPTION USABLE ON CODE	(8) QTY INC IN UNIT
GROUP 0708 EXTENDER,MODULE MX-4906/ARC-51X							
31	1	PAOZZ	5935-00-954-4470	SKT41WHITE	98291	JACK,TIP	EA 7
31	2	PAOZZ	5935-00-061-1363	SKT41RED	98291	JACK,TIP	EA 2
31	3	XDOOO		761-7003-001	13499	CABLE ASSEMBLY	EA 4
31	4	XDOZZ		756-8933-001	13499	CHASSIS,MDL EXT	EA 1
31	5	PAOZZ	5935-00-885-6505	DM53740-5000	71468	CONNECTOR,PLUG,ELEC	EA 4
31	6	PAOZZ	5935-00-710-1717	DE9P	71468	CONNECTOR,RECEPTACL	EA 1
31	7	PAOZZ	5310-00-938-2013	MS35649-24	96906	NUT,PLAIN,HEXAGON	EA 4
31	8	PAOZZ	5305-00-727-8833	MS51959-3	96906	SCREW,MACHINE	EA 2
31	9	XDOOO		761-7002-001	13499	WIRING HARNESS	EA 1
31	10	PAOZZ	6625-00-058-3811	756-8926-001	13499	RETAINER,COUPLING	EA 1
31	11	PAOZZ	5330-00-824-9130	213-141216-00-23 03	78189	PACKING PREFORMED	EA 1
31	12	PAOZZ	5365-00-695-2558	340-0642-00	91314	RING,RETAINING	EA 2
31	13	PAOZZ	5340-00-479-9197	MS122119	96906	INSERT,SCREW THREAD	EA 2
31	14	PAOZZ	5305-00-909-1949	756-8924-001	13499	SCREW,CAP, SOCKET HE	EA 2
31	15	PAOZZ	6625-00-058-3841	761-7006-002	13499	SHAFT AND PIN ASSEM	EA 1
31	16	PAOZZ	5310-00-058-2949	310-0278-000	70318	WASHER, LOCK	EA 4
31	17	PAOZZ	5305-00-054-5646	MS51957-12	96906	SCREW,MACHINE	EA 4
31	18	XDOZZ		756-8922-001	13499	PLATE,RTNG,SFT	EA 1
31	19	PAOZZ	5821-00-021-4832	549-3856-002	13499	INSERT,FLEXIBLE COU	EA 1
31	20	XDOZZ		756-8927-001	13499	PIN,LOCATING	EA 2
31	21	PAOZZ	5315-00-291-5471	MS16562-189	96906	PIN,SPRING	EA 4
31	22	XDOZZ		CA5123-1	71468	PLATE ASSEMBLY	EA 1
31	23	PAOZZ	5305-00-763-3356	MS51959-5	96906	SCREW,MACHINE	EA 2
31	24	PAOZZ	5310-00-907-0959	310-6320-000	79847	WASHER,FLAT	EA 2
31	25	PAOZZ	5310-00-928-2690	310-0070-000	79807	WASHER, LOCK	EA 4
31	26	PAOZZ	5935-00-901-5204	DEF9S	71468	CONNECTOR,RECEPTACL	EA 1
31	27	PAOZZ	5935-00-080-0268	DM53742-5000	71468	CONNECTOR,PLUG,ELEC	EA 4
31	28	PAOZZ	5340-00-058-3808	756-8923-001	13499	POST,ELECTRICAL-MEC	EA 1
31	29	XDOZZ		756-8925-001	13499	COVER,MDL EXTEN	EA 1
31	30	PAOZZ	5305-00-054-6651	MS51957-27	96906	SCREW,MACHINE	EA 2
31	31	PAOZZ	5310-00-929-6395	310-0071-000	79807	WASHER, LOCK	EA 2
31	32	XDOZZ		756-8925-002	13499	COVER,MDL EXTEN	EA 1

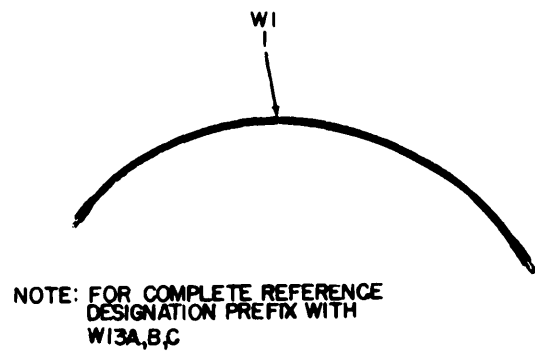

EL4HK045

Figure 32. Cable Assembly, RF CG-3120/ARC-51X.

SECTION II

(1)	(2)	(3)	(4)	(5)	(6)	(7)	(8)	
ILLUSTRATION							QTY	
(A)	(B)	NATIONAL			DESCRIPTION		INC	
FIG	ITEM	SMR	STOCK	PART			IN	
NO	NO	CODE	NUMBER	NUMBER	FSCM	USABLE ON CODE	U/M	UNIT

GROUP 08 CABLE ASSEMBLY,RF CG-3120/ARC-51X

32	1	XDOZZ		CA53693-80	71468		CABLE ASSEMBLY,RADI	EA	1
----	---	-------	--	------------	-------	--	---------------------	----	---

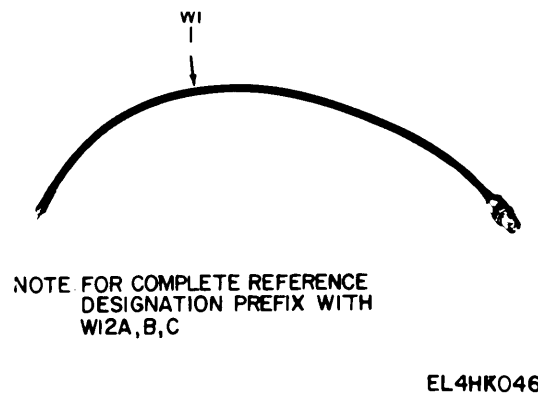

Figure 33. Cable Assembly, RF CG-3119/ARC-51X.

SECTION II

(1)	(2)	(3)	(4)	(5)	(6)	(7)	(8)	
ILLUSTRATION								
(A)	(B)		NATIONAL		DESCRIPTION		QTY	
FIG	ITEM	SMR	STOCK	PART			INC	
NO	NO	CODE	NUMBER	NUMBER	FSCM	USABLE ON CODE	U/M	UNIT

GROUP 09 CABLE ASSEMBLY,RF CG-3119/ARC-51X

33	1	PAOZZ	6625-00-823-5343	CA53693-79	71468		CABLE ASSEMBLY,RADI	EA	1
----	---	-------	------------------	------------	-------	--	---------------------	----	---

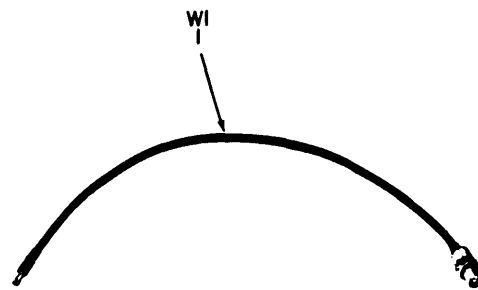

NOTE: FOR COMPLETE REFERENCE
DESIGNATION PREFIX WITH
WIIA,B,C

EL4HK047

Figure 34. Cable Assembly, RF CG-3118/ARC-51X.

SECTION II

(1)	(2)	(3)	(4)	(5)	(6)	(7)	(8)	
ILLUSTRATION							QTY	
(A)	(B)	NATIONAL			DESCRIPTION		INC	
FIG	ITEM	SMR	STOCK	PART			IN	
NO	NO	CODE	NUMBER	NUMBER	FSCM	USABLE ON CODE	U/M	UNIT

GROUP 10 CABLE ASSEMBLY,RF CG-3118/ARC-51X

34	1	PAOZZ	6625-00-823-5342	CA53693-78	71468	CABLE ASSEMBLY,RADI	EA	1
----	---	-------	------------------	------------	-------	---------------------	----	---

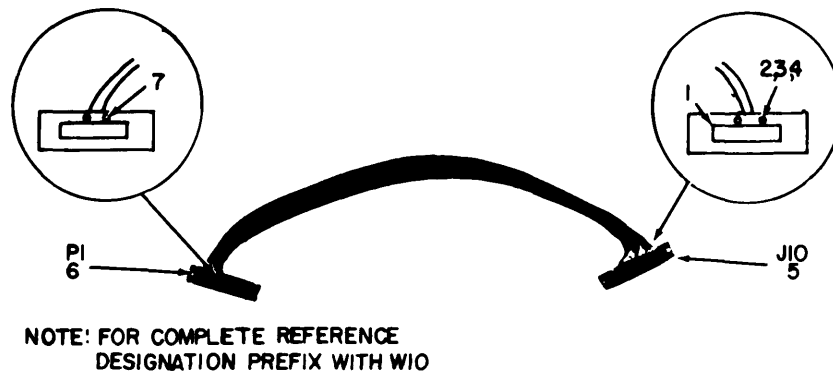

EL4HK048

Figure 35. Cable Assembly, Special Purpose, Electrical CX-10191/ARC-51X.

SECTION II

(1)	(2)	(3)	(4)	(5)	(6)	(7)	(8)	
ILLUSTRATION							QTY	
(A)	(B)	NATIONAL			DESCRIPTION		INC	
FIG	ITEM	SMR	STOCK	PART			IN	
NO	NO	CODE	NUMBER	NUMBER	FSCM	USABLE ON CODE	U/M	UNIT

GROUP 11 CABLE ASSEMBLY,SPECIAL PURPOSE,

ELECTRICAL CX-10191/ARC-51X

35	1	PAOZZ	5935-00-722-4350	DB-24659	71768	SHIELD,ELEC CON	EA	2
35	2	PAOZZ	5310-00-622-1724	68-1660-26	72962	NUT,SELF-LOCKING,HE	EA	4
35	3	PAOZZ	5305-00-054-5638	MS51957-4	96906	SCREW,MACHINE	EA	2
35	4	PAOZZ	5310-00-929-1748	310-0129-00	05411	WASHER,FLAT	EA	4
35	5	PAOZZ	5935-00-883-0218	DBMF25S	71768	CONNECTOR,RCPT	EA	1
35	6	PAOZZ	5935-01-029-7458	DBM25P	71468	CONNECTOR,RECEPTACL	EA	1
35	7	PAOZZ	5305-00-727-8833	MS51959-3	96906	SCREW,MACHINE	EA	2

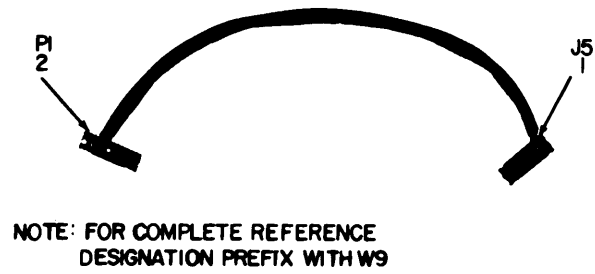

EL4HK049

Figure 36. Cable Assembly, Special Purpose, Electrical CX-10190/ARC-51X.

SECTION II

(1)	(2)	(3)	(4)	(5)	(6)	(7)	(8)
ILLUSTRATION							QTY
(A)	(B)	NATIONAL			DESCRIPTION		INC
FIG	ITEM	SMR	STOCK	PART			IN
NO	NO	CODE	NUMBER	NUMBER	FSCM	USABLE ON CODE	U/M
							UNIT

GROUP 12 CABLE ASSEMBLY,SPECIAL PURPOSE,

ELECTRICAL CX-10190/ARC-51X

36	1	PAOZZ	5935-00-059-2640	DAMF11W1S	71468	CONNECTOR,RECEPTACL	EA	1
36	2	PAOZZ	5935-00-901-5850	DAM11W1P	71468	CONNECTOR,RECEPTACL	EA	1

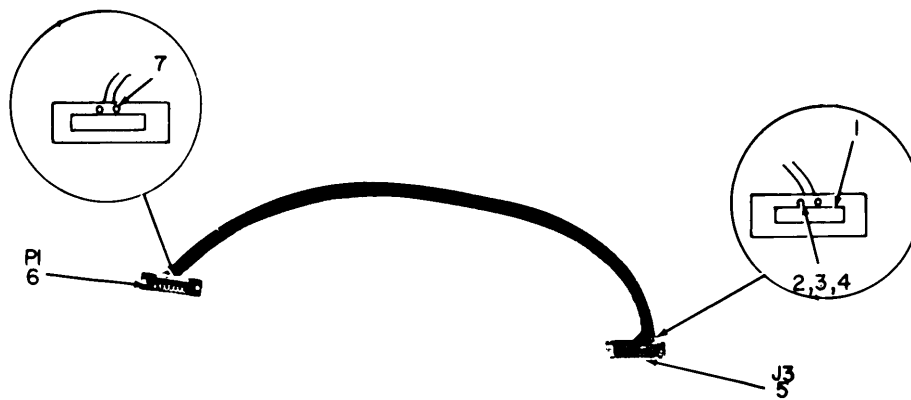

NOTE: FOR COMPLETE REFERENCE
DESIGNATION PREFIX WITH
W8A,B

EL4HK050

Figure 37. Cable Assembly, Special Purpose, Electrical CX-10189/ARC-51X.

SECTION II

(1)	(2)	(3)	(4)	(5)	(6)	(7)	(8)	
ILLUSTRATION							QTY	
(A)	(B)	NATIONAL			DESCRIPTION		INC	
FIG	ITEM	SMR	STOCK	PART			IN	
NO	NO	CODE	NUMBER	NUMBER	FSCM	USABLE ON CODE	U/M	UNIT

GROUP 13 CABLE ASSEMBLY,SPECIAL PURPOSE,

ELECTRICAL CX-10189/ARC-51X

37	1	PAOZZ	5935-00-722-4348	024658-0000	71468	SHIELD,ELECTRICAL C	EA	2
37	2	PAOZZ	5310-00-622-1724	68-1660-26	72962	NUT,SELF-LOCKING,HE	EA	4
37	3	PAOZZ	5305-00-727-8833	MS51959-3	96906	SCREW,MACHINE	EA	2
37	4	PAOZZ	5310-00-929-1748	310-0129-00	05411	WASHER,FLAT	EA	4
37	5	PAOZZ	5935-00-993-2181	DAF15S	71468	CONNECTOR,RECEPTACL	EA	1
37	6	PAOZZ	5935-00-057-2690	DA15P	71468	CONNECTOR,RECEPTACL	EA	1
37	7	PAOZZ	5305-00-054-5638	MS51957-4	96906	SCREW,MACHINE	EA	2



NOTE: FOR COMPLETE REFERENCE
DESIGNATION PREFIX WITH W7

EL4HK05I

Figure 38. Cable Assembly, Special Purpose, Electrical CX-10188/ARC-51X.

SECTION II

(1)	(2)	(3)	(4)	(5)	(6)	(7)	(8)	
ILLUSTRATION							QTY	
(A)	(B)	NATIONAL			DESCRIPTION		INC	
FIG	ITEM	SMR	STOCK	PART			IN	
NO	NO	CODE	NUMBER	NUMBER	FSCM	USABLE ON CODE	U/M	UNIT

GROUP 14 CABLE ASSEMBLY,SPECIAL PURPOSE,

ELECTRICAL CX-10188/ARC-51X

38	1	PAOZZ	5935-00-089-1165	DBMF13W3S	71468	CONNECTOR,RECEPTACL	EA	1
38	2	PAOZZ	5935-00-811-1382	DBM13W3P	71468	CONNECTOR,RECEPTACL	EA	1

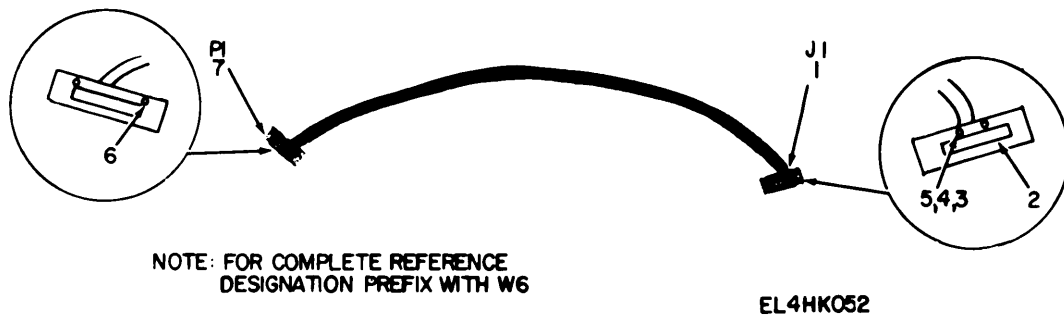

Figure 39. Cable Assembly, Special Purpose, Electrical CX-10187/ARC-51X.

SECTION II

(1)	(2)	(3)	(4)	(5)	(6)	(7)	(8)	
ILLUSTRATION							QTY	
(A)	(B)	NATIONAL			DESCRIPTION		INC	
FIG	ITEM	SMR	STOCK	PART			IN	
NO	NO	CODE	NUMBER	NUMBER	FSCM	USABLE ON CODE	U/M	UNIT

GROUP 15 CABLE ASSEMBLY,SPECIAL PURPOSE,

ELECTRICAL CX-10187/ARC-51X

39	1	PAOZZ	5935-00-901-5204	DEF9S	71468	CONNECTOR,RECEPTACL	EA	1
39	2	PAOZZ	5935-00-716-6591	024657-0000	71468	SHIELD,ELECTRICAL C	EA	2
39	3	PAOZZ	5310-00-622-1724	68-1660-26	72962	NUT,SELF-LOCKING,HE	EA	4
39	4	PAOZZ	5305-00-054-5638	MS51957-4	96906	SCREW,MACHINE	EA	2
39	5	PAOZZ	5310-00-929-1748	310-0129-00	05411	WASHER,FLAT	EA	4
39	6	PAOZZ	5305-00-727-8833	MS51959-3	96906	SCREW,MACHINE	EA	2
39	7	PAOZZ	5935-00-710-1717	DE9P	71468	CONNECTOR,RECEPTACL	EA	1

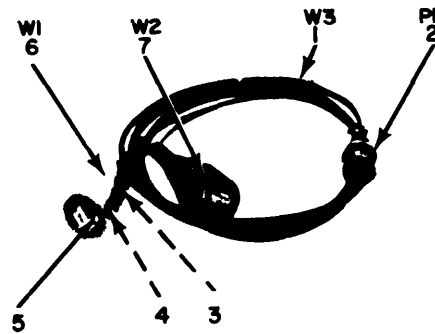

NOTE: FOR COMPLETE REFERENCE DESIGNATION
PREFIX WITH W5.

EL4HK053

Figure 40. Cable Assembly, Power, Electrical, Branched CX-10186/ARC-51X

SECTION II

(1)	(2)	(3)	(4)	(5)	(6)	(7)	(8)	
ILLUSTRATION							QTY	
(A)	(B)	NATIONAL			DESCRIPTION		INC	
FIG	ITEM	SMR	STOCK	PART			IN	
NO	NO	CODE	NUMBER	NUMBER	FSCM	USABLE ON CODE	U/M	UNIT
GROUP 16 CABLE ASSEMBLY, POWER, ELECTRICAL,								
BRANCHED CX-10186/ARC-51X								
40	1	XDOZZ		T5975	71124	CABLE, SP, ELEC	FT	1
40	2	PAOZZ	5935-00-901-8871	MS3116F12-3S	96906	CONNECTOR, PLUG, ELEC	EA	1
40	3	PAOZZ	5940-00-143-4774	31902	00779	TERMINAL, LUG	EA	2
40	4	PAOZZ	5310-00-190-7693	310-0079-000	13499	WASHER, LOCK	EA	2
40	5	PAOZZ	5940-00-941-1933	24A	76545	CLIP, ELECTRICAL	EA	2
40	6	PAOZZ	5975-00-281-0034	26	76545	CABLE NIPPLE, EL	EA	1
40	7	XDOZZ		26BLK	76545	CABLE NIPPLE, EL	EA	1

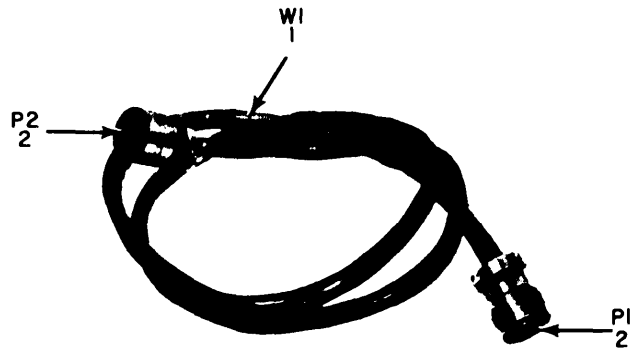

NOTE: FOR COMPLETE REFERENCE DESIGNATION
PREFIX WITH W4.

EL4HK054

Figure 41. Cable Assembly, Special Purpose, Electrical CX-10185/ARC-51X.

SECTION II

(1)	(2)	(3)	(4)	(5)	(6)	(7)	(8)
ILLUSTRATION						QTY	
(A)	(B)	NATIONAL			DESCRIPTION	INC	
FIG	ITEM	SMR	STOCK	PART		IN	
NO	NO	CODE	NUMBER	NUMBER	FSCM	USABLE ON CODE	U/M UNIT
					GROUP 17 CABLE ASSEMBLY,SPECIAL PURPOSE,		
					ELECTRICAL CX-10185/ARC-51X		
41	1	XDOZZ		T6009	71124 CABLE,SP,ELEC	FT	1
41	2	PAOZZ	5935-00-717-2591	MS3116F18-32S	96906 CONNECTOR,PLUG,ELEC	EA	2

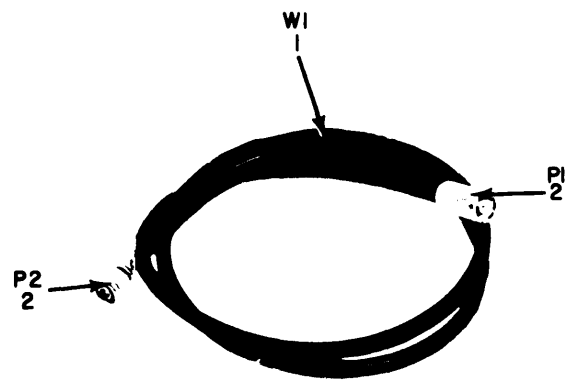

NOTE: FOR COMPLETE REFERENCE DESIGNATION
PREFIX WITH W3.

EL4HK055

Figure 42. Cable Assembly, RF CG-1889/U.

SECTION II

(1)	(2)	(3)	(4)	(5)	(6)	(7)	(8)
ILLUSTRATION							QTY
(A)	(B)		NATIONAL				INC
FIG	ITEM	SMR	STOCK	PART		DESCRIPTION	IN
NO	NO	CODE	NUMBER	NUMBER	FSCM	USABLE ON CODE	U/M UNIT

GROUP 18 CABLE ASSEMBLY,RF CG-1889/U

42	1	PAOZZ	6145-00-660-8711	RG213U	80058	CABLE,RADIO FREQUEN	FT	1
42	2	PAOZZ	5935-00-577-8776	UG21EU	80058	CONNECTOR	EA	2

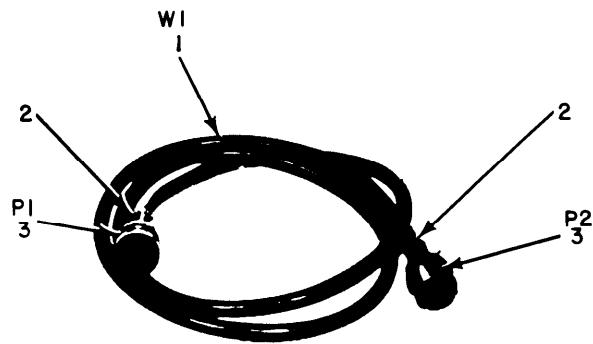

NOTE: FOR COMPLETE REFERENCE DESIGNATION
PREFIX WITH W2

EL4HK056

Figure 43. Cable Assembly, Special Purpose, Electrical CX-9053/ARC-51X.

SECTION II

(1)	(2)	(3)	(4)	(5)	(6)	(7)	(8)
ILLUSTRATION						QTY	
(A)	(B)	NATIONAL			DESCRIPTION	INC	
FIG	ITEM	SMR	STOCK	PART		IN	
NO	NO	CODE	NUMBER	NUMBER	FSCM	USABLE ON CODE	U/M UNIT
GROUP 19 CABLE ASSEMBLY, SPECIAL PURPOSE,							
ELECTRICAL CX-9053/ARC-51X							
43	1	XDOZZ		T6010	71124	CABLE, SP, ELEC	FT 1
43	2	XDOZZ		761-5950-001	13499	SLEEVE, EXTENSIO	EA 2
43	3	PAOZZ	5935-00-903-3513	PTO6E16-26SWR	77820	CONNECTOR, PLUG, ELEC	EA 2

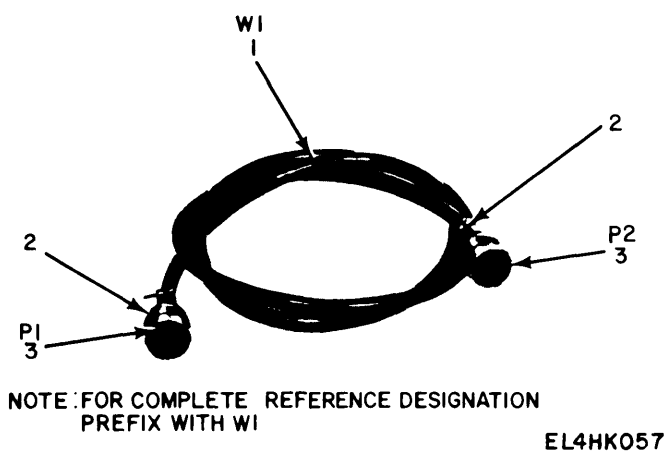

Figure 44. Cable Assembly, Special Purpose, Electrical CX-9052/ARC-51X.

SECTION II

(1)	(2)	(3)	(4)	(5)	(6)	(7)	(8)	
ILLUSTRATION							QTY	
(A)	(B)	NATIONAL			DESCRIPTION		INC	
FIG	ITEM	SMR	STOCK	PART			IN	
NO	NO	CODE	NUMBER	NUMBER	FSCM	USABLE ON CODE	U/M	UNIT

GROUP 20 CABLE ASSEMBLY,SPECIAL PURPOSE,

ELECTRICAL CX-9052/ARC-51X

44	1	XDOZZ		T6010	71124	CABLE, SP, ELEC		FT 1
44	2	XDOZZ		761-5950-001	13499	SLEEVE, EXTENSIO		EA 2
44	3	PAOZZ	5935-00-903-3512	PTO6E16-26 SSR	77820	CONNECTOR, PLUG, ELEC		EA 2

SECTION IV

NATIONAL STOCK NUMBER AND PART NUMBER INDEX

NOTE: LATEST NATIONAL STOCK NUMBER AND PART NUMBER ASSIGNMENTS ARE INCLUDED AT END OF INDEX

STOCK NUMBER	FIGURE NO	ITEM NO	STOCK NUMBER	FIGURE NO	ITEM NO
5340-00-003-6667	5	47	5305-00-054-6651	26	11
5905-00-005-2868	13	26	5305-00-054-6651	27	9
5940-00-007-5277	10	34	5305-00-054-6651	28	5
5910-00-010-8158	17	30	5305-00-054-6651	29	6
5120-00-013-7117	4	18	5305-00-054-6651	30	24
5950-00-015-6791	13	4	5305-00-054-6651	31	30
3040-00-016-2719	1	25	5305-00-054-6652	1	35
5321-00-021-4832	26	38	5305-00-054-6652	5	95
5821-00-021-4832	27	23	5305-00-054-6652	9	5
5821-00-021-4832	31	19	5305-00-054-6652	15	14
5120-00-022-7793	4	23	5305-00-054-6652	18	2
5821-00-043-1974	30	29	5305-00-054-6672	1	26
5910-00-043-1994	6	38	5935-00-057-2690	24	7
5910-00-043-1994	11	14	5935-00-057-2690	26	33
5910-00-043-1994	17	32	5935-00-057-2690	28	10
5950-00-043-4837	10	61	5935-00-057-2690	29	19
5905-00-045-5422	9	23	5935-00-057-2690	37	6
5905-00-050-7383	10	54	5340-00-058-3808	31	28
5310-00-053-1551	7	4	6625-00-058-3811	26	39
5310-00-053-1551	17	22	6625-00-058-3811	27	22
5305-00-054-5635	18	6	6625-00-058-3811	30	30
5305-00-054-5635	23	29	6625-00-058-3811	31	10
5305-00-054-5635	24	4	6625-00-058-3841	26	37
5305-00-054-5635	25	11	6625-00-058-3841	27	18
5305-00-054-5635	26	25	6625-00-058-3841	30	28
5305-00-054-5635	27	17	6625-00-058-3841	31	15
5305-00-054-5636	1	8	5935-00-059-2640	25	8
5305-00-054-5636	10	23	5935-00-059-2640	27	28
5305-00-054-5636	15	58	5935-00-059-2640	36	1
5305-00-054-5637	12	30	5950-00-059-5921	10	14
5305-00-054-5637	13	18	5910-00-060-1194	8	17
5305-00-054-5638	1	13	5935-00-061-1363	24	21
5305-00-054-5638	5	105	5935-00-061-1363	26	2
5305-00-054-5638	15	70	5935-00-061-1363	27	2
5305-00-054-5638	35	3	5935-00-061-1363	28	20
5305-00-054-5638	37	7	5935-00-061-1363	31	2
5305-00-054-5638	39	4	5365-00-064-1922	6	10
5305-00-054-5639	10	31	5910-00-067-7293	11	33
5305-00-054-5639	12	39	5305-00-071-1320	5	34
5305-00-054-5640	5	91	5305-00-071-1320	15	41
5305-00-054-5642	12	73	5935-00-080-0268	25	16
5305-00-054-5645	12	5	5935-00-080-0268	26	20
5305-00-054-5646	6	40	5935-00-080-0268	27	29
5305-00-054-5646	10	48	5935-00-080-0268	30	1
5305-00-054-5646	11	10	5935-00-080-0268	31	27
5305-00-054-5646	23	31	5820-00-086-8724	15	56
5305-00-054-5646	26	4	5945-00-086-8876	5	68
5305-00-054-5646	27	20	5935-00-088-9619	26	35
5305-00-054-5646	30	20	5935-00-089-1165	30	18
5305-00-054-5646	31	17	5935-00-089-1165	38	1
5305-00-054-5647	5	66	5935-00-089-6505	26	32
5305-00-054-5647	7	10	5935-00-089-6921	26	19
5305-00-054-5647	7	13	6625-00-089-7164	1	1
5305-00-054-5647	13	35	5905-00-104-8363	10	17
5305-00-054-5647	17	23	5905-00-110-0991	9	16
5305-00-054-5647	20	3	5905-00-111-4742	6	19
5305-00-054-5647	21	3	5905-00-111-8357	10	64
5305-00-054-5648	1	30	5905-00-114-5381	13	34
5305-00-054-5648	5	28	5905-00-120-9154	10	66
5305-00-054-5648	7	2	5905-00-141-0592	6	30
5305-00-054-5648	9	20	5905-00-141-1149	11	20
5305-00-054-5648	13	6	5940-00-143-4774	40	3
5305-00-054-5648	15	50	6625-00-143-6716	5	1
5305-00-054-5648	15	55	5140-00-152-2514	4	3
5305-00-054-5648	23	9	5120-00-152-2516	4	1
5305-00-054-5649	12	42	6240-00-155-7836	5	16
5305-00-054-5649	23	28	6240-00-155-7836	12	40
5305-00-054-5650	23	27	6240-00-155-7836	15	2
5305-00-054-5651	2	4	5905-00-156-0435	9	19
5305-00-054-5651	5	37	5905-00-171-1975	18	24
5305-00-054-5653	23	21	5905-00-171-2006	6	6
5305-00-054-5654	6	9	5325-00-174-5317	7	12
5305-00-054-6650	5	42	5325-00-174-5317	23	33
5305-00-054-6650	12	63	5905-00-190-8879	16	16
5305-00-054-6650	13	11	5905-00-190-8883	6	16
5305-00-054-6651	10	37	5905-00-190-8883	8	10
5305-00-054-6651	15	45	5905-00-192-3971	8	14
5305-00-054-6651	18	15	5905-00-192-3973	8	12
5305-00-054-6651	24	22	5905-00-192-4490	17	7
5305-00-054-6651	25	4	5905-00-195-6453	6	2

TM11-6625-564-40P
SECTION IV
NATIONAL STOCK NUMBER AND PART NUMBER INDEX

STOCK NUMBER	FIGURE NO	ITEM NO	STOCK NUMBER	FIGURE NO	ITEM NO
5905-00-195-6453	8	15	5340-00-479-9197	26	28
5905-00-195-6453	17	3	5340-00-479-9197	27	14
5905-00-195-6741	6	5	5340-00-479-9197	28	15
5905-00-195-6761	5	5	5340-00-479-9197	29	13
5905-00-195-6800	6	3	5340-00-479-9197	30	9
5905-00-195-6800	17	2	5340-00-479-9197	31	13
5905-00-195-6806	5	49	5310-00-493-1738	5	23
5905-00-195-6806	6	35	5310-00-493-1738	15	6
5905-00-195-6806	17	9	5940-00-501-8634	13	1
5905-00-195-6817	16	12	5940-00-501-8634	15	21
5935-00-199-1790	10	53	5930-00-504-6223	5	71
5935-00-199-1790	11	15	5325-00-505-4798	15	10
5365-00-200-3475	12	26	5310-00-515-8243	9	6
5365-00-200-3475	12	29	5310-00-515-8243	18	33
5305-00-207-7463	5	25	6145-00-542-6092	15	24
5305-00-207-7463	15	7	6145-00-542-6092	15	29
5305-00-207-7465	5	24	5310-00-543-5933	10	43
5305-00-207-7465	11	41	5310-00-550-3715	1	17
5305-00-207-7465	15	5	5935-00-552-7660	16	11
5305-00-207-7468	5	12	5925-00-556-7530	5	94
5310-00-208-3786	5	53	5961-00-577-6084	10	18
5310-00-208-3786	5	65	5961-00-577-6214	12	2
5310-00-208-3786	6	39	5961-00-577-6214	15	59
5310-00-208-3786	7	9	5935-00-577-8776	42	2
5310-00-208-3786	7	9	5935-00-578-3489	42	2
5310-00-208-3786	12	67	5935-00-578-3489	15	33
5310-00-208-3786	15	53	5935-00-581-6941	10	33
5310-00-208-3786	17	11	5935-00-581-6941	11	34
5310-00-208-3786	23	20	5961-00-586-5131	10	44
5940-00-225-6449	13	22	5310-00-591-3416	9	14
5940-00-225-6449	15	66	5310-00-614-3500	9	13
5940-00-225-6449	16	4	5940-00-615-8958	13	30
5905-00-247-8722	317	28	5910-00-617-4948	11	27
5310-00-268-6116	11	40	5120-00-618-4433	4	6
5940-00-269-2219	15	22	5310-00-622-1724	10	30
5310-00-270-8810	10	41	5310-00-622-1724	35	2
5310-00-271-4642	6	20	5310-00-622-1724	37	2
5310-00-275-5147	5	29	5310-00-622-1724	39	3
5310-00-275-5147	18	21	5960-00-636-0183	11	4
5905-00-279-1751	8	2	5305-00-637-5884	16	9
5905-00-279-1756	15	40	5905-00-644-9545	6	5
5905-00-279-1756	18	25	5905-00-644-9545	17	20
5905-00-279-1876	6	34	5961-00-649-9371	13	5
5905-00-279-1876	8	5	5930-00-655-1523	15	42
5905-00-279-1876	17	6	5930-00-655-1582	15	43
5905-00-279-1877	15	65	6145-00-660-8711	42	1
5905-00-279-1880	6	27	5905-00-681-5977	5	98
5905-00-279-1880	8	1	5935-00-682-0501	15	28
5905-00-279-1880	17	38	5940-00-682-2477	15	52
5905-00-279-1897	6	29	5905-00-682-4105	11	31
5905-00-279-2616	6	4	5905-00-683-7721	10	68
5905-00-279-2616	8	6	5905-00-683-7721	11	30
5905-00-279-2616	15	63	5310-00-685-1450	10	42
5905-00-279-2616	17	26	5305-00-685-7072	10	24
5905-00-279-2658	9	15	5930-00-685-9521	5	73
5905-00-279-3497	6	28	5905-00-686-4528	10	13
5905-00-279-3502	6	7	5905-00-687-0000	10	63
5905-00-279-3502	8	11	5905-00-688-4447	13	28
5905-00-279-3506	11	1	5961-00-688-6316	13	28
5325-00-290-3969	18	3	5365-00-695-2558	1	22
5315-00-291-5471	24	16	5365-00-695-2558	12	61
5315-00-291-5471	25	24	5365-00-695-2558	24	12
5315-00-291-5471	26	22	5365-00-695-2558	25	14
5315-00-291-5471	27	25	5365-00-695-2558	26	29
5315-00-291-5471	27	25	5365-00-695-2558	26	29
5315-00-291-5471	28	14	5365-00-695-2558	27	13
5315-00-291-5471	29	12	5365-00-695-2558	28	11
5315-00-291-5471	30	5	5365-00-695-2558	28	11
5315-00-291-5471	31	21	5365-00-695-2558	30	13
5315-00-297-0875	4	22	5365-00-695-2558	31	12
5315-00-297-0875	5	104	5940-00-700-2971	6	24
5315-00-297-0875	15	73	5940-00-700-2971	7	5
5905-00-299-1541	17	27	5940-00-700-2971	9	1
5905-00-299-1971	5	44	5940-00-700-2971	12	65
5310-00-316-9040	10	9	5940-00-700-2971	13	19
5940-00-356-2493	15	19	5940-00-700-2971	16	6
5910-00-420-8555	15	62	5940-00-700-2971	17	15
5999-00-441-1688	9	3	6625-00-702-0287	15	9
5905-00-465-9557	10	16	5355-00-702-2704	16	1
5995-00-467-3887	3	3	5910-00-702-3768	10	52
5340-00-479-9197	3	3	5935-00-710-1717	10	52
5340-00-479-9197	25	9	5935-00-710-1717	39	7

SECTION IV

NATIONAL STOCK NUMBER AND PART NUMBER INDEX

STOCK NUMBER	FIGURE NO	ITEM NO	STOCK NUMBER	FIGURE NO	ITEM NO
5935-00-716-6591	39	2	6210-00-767-6246	15	3
5305-00-716-7733	12	43	5305-00-770-2533	5	96
5935-00-717-2591	41	2	5305-00-770-2533	13	15
5305-00-719-5342	5	4	5305-00-777-6039	23	26
5305-00-719-5342	18	8	5970-00-779-4913	12	38
5120-00-720-1908	4	17	5910-00-781-3239	10	11
5935-00-722-4348	37	1	5910-00-781-3239	11	21
5340-00-722-8713	23	25	5310-00-782-1349	5	38
5940-00-723-2876	10	19	5310-00-782-1349	6	21
5985-00-726-2290	1	4	5310-00-782-1349	15	54
5910-00-726-2448	11	7	5310-00-782-1349	17	12
5905-00-726-5346	10	67	5821-00-785-6853	5	36
5905-00-726-6433	10	60	5905-00-801-1217	5	84
5905-00-726-7545	5	86	5905-00-802-0898	5	85
5305-00-727-8833	24	19	5330-00-802-4290	12	6
5305-00-727-8833	25	9	5910-00-804-7566	16	17
5305-00-727-8833	26	30	5935-00-809-8808	15	16
5305-00-727-8833	27	7	5310-00-811-0494	5	79
5305-00-727-8833	28	17	5935-00-811-1382	30	8
5305-00-727-8833	29	18	5935-00-811-1382	38	2
5305-00-727-8833	30	17	5905-00-811-4758	5	100
5305-00-727-8833	31	8	5905-00-816-8554	10	57
5305-00-727-8833	35	7	5960-00-819-3926	11	12
5305-00-727-8833	37	3	5935-00-823-0212	20	2
5305-00-727-8833	39	6	5935-00-823-0487	5	50
5961-00-732-5028	10	77	5935-00-823-0487	5	51
5950-00-734-3940	11	36	5935-00-823-0487	15	17
5940-00-738-1265	5	69	5910-00-823-1687	13	8
5940-00-738-1255	15	32	5905-00-823-3479	5	99
6625-00-738-5973	1	1	6625-00-823-5342	34	1
6625-00-738-5975	23	15	6625-00-823-5343	33	1
6625-00-738-5976	1	6	3040-00-823-5347	12	49
6625-00-738-5977	23	14	6625-00-823-5348	5	7
6625-00-738-5978	23	16	5330-00-823-5366	5	97
6625-00-738-5979	23	13	5985-00-824-3677	5	41
6625-00-738-5980	23	12	5905-00-825-2360	10	73
6625-00-738-5981	23	18	5905-00-825-2360	11	22
6625-00-738-5982	23	11	5935-00-835-3031	21	2
6625-00-738-5983	23	17	5961-00-836-0377	9	8
6625-00-738-5984	2	6	5935-00-836-1804	5	31
6625-00-738-5986	2	2	5935-00-836-1804	15	5
6625-00-738-5989	2	1	5961-00-837-9288	5	83
6625-00-738-5990	2	3	5905-00-845-9472	5	81
6625-00-738-5991	1	3	5961-00-847-5244	10	74
6625-00-738-5991	22	1	5961-00-850-9440	9	18
5180-00-738-6019	1	7	4320-00-854-4444	4	14
5905-00-752-3335	10	27	5945-00-854-8546	12	64
5905-00-752-3338	10	76	5960-00-855-2102	11	43
5905-00-752-3338	11	26	5310-00-857-5547	5	59
3020-00-752-7989	12	20	5310-00-857-5548	5	55
5905-00-755-2346	5	101	5940-00-877-8430	10	40
5905-00-755-2571	10	58	5940-00-877-8430	12	71
3120-00-757-2279	12	27	5940-00-878-3768	5	72
5935-00-762-9306	3	8	5940-00-878-3768	15	47
5935-00-762-9307	3	11	5905-00-879-3636	13	24
5305-00-763-3356	24	8	5905-00-880-0437	10	56
5305-00-763-3356	25	6	5945-00-880-8747	5	89
5305-00-763-3356	26	17	6210-00-881-1507	5	22
5305-00-763-3356	27	30	6210-00-881-1507	15	34
5305-00-763-3356	28	7	5935-00-881-9480	26	7
5305-00-763-3356	29	8	5935-00-885-6505	25	10
5305-00-763-3356	30	10	5935-00-885-6505	26	26
5305-00-763-3356	31	23	5935-00-885-6505	27	4
5305-00-763-6962	18	19	5935-00-885-6505	30	7
5305-00-763-6963	1	33	5935-00-885-6505	31	5
5305-00-763-7822	5	56	5905-00-889-0201	0	47
5305-00-763-7822	12	34	5910-00-890-8988	10	4
5305-00-763-7822	23	4	5961-00-892-1009	10	65
5305-00-764-2964	5	62	5950-00-892-8301	10	28
5305-00-764-2964	15	12	5950-00-899-9275	12	16
5305-00-764-2964	18	14	5935-00-901-5204	31	26
5305-00-764-2966	1	27	5935-00-901-5204	39	1
5305-00-764-2966	11	7	5935-00-901-5850	25	17
5950-00-764-3186	16	15	5935-00-901-5850	27	5
5950-00-764-3188	11	37	5935-00-901-5850	36	2
5950-00-764-4034	11	16	5935-00-901-8871	40	2
5950-00-764-9764	11	18	5310-00-903-1509	17	24
5821-00-766-1968	12	23	5935-00-903-3512	44	3
6210-00-767-6246	5	17	5935-00-903-3513	43	3

SECTION IV

NATIONAL STOCK NUMBER AND PART NUMBER INDEX

STOCK NUMBER	FIGURE NO	ITEM NO	STOCK NUMBER	FIGURE NO	ITEM NO
5999-00-904-3486	6	13	5310-00-929-6395	24	23
5999-00-904-3436	8	8	5310-00-929-6395	25	2
5910-00-904-3985	6	32	5310-00-929-6395	26	12
5910-00-904-3985	8	18	5310-00-929-6395	27	10
5910-00-904-3985	17	21	5310-00-929-6395	28	6
5910-00-904-5644	6	37	5310-00-929-6395	29	7
5940-00-904-6646	11	44	5310-00-929-6395	30	25
5940-00-904-9633	10	38	5310-00-929-6395	31	31
5961-00-905-4815	10	75	5340-00-930-0107	23	8
5935-00-906-6334	5	19	5340-00-930-0835	23	24
5935-00-906-6334	15	23	5360-00-931-9409	12	13
5935-00-906-6335	18	9	5310-00-933-8118	1	31
6625-00-906-6365	5	18	5310-00-933-8118	5	67
6625-00-906-6366	5	1	5310-00-933-8118	6	11
6625-00-906-6367	5	5	5310-00-933-8118	6	41
5140-00-906-6373	4	26	5310-00-933-8118	7	3
5120-00-906-6376	4	25	5310-00-933-8118	7	14
5120-00-906-6377	4	4	5310-00-933-8118	12	33
5120-00-906-6379	4	5	5310-00-933-8118	13	36
5120-00-906-6380	4	24	5310-00-933-8118	17	25
5950-00-906-6388	12	15	5310-00-933-8118	23	32
5950-00-906-6390	11	9	5310-00-938-2013	1	12
5950-00-906-6392	6	22	5310-00-938-2013	1	20
5950-00-906-6392	17	3	5310-00-938-2013	5	60
5120-00-908-4752	4	10	5310-00-938-2013	5	90
5120-00-908-4754	4	27	5310-00-938-2013	10	8
5821-00-908-4758	14	3	5310-00-938-2013	12	36
5355-00-908-4763	5	3	5310-00-938-2013	15	11
4910-00-908-6709	4	16	5310-00-938-2013	18	13
6625-00-908-7384	14	4	5310-00-938-2013	24	10
6625-00-908-7385	5	20	5310-00-938-2013	25	18
6625-00-908-7386	5	13	5310-00-938-2013	26	16
6625-00-908-7390	14	2	5310-00-938-2013	27	6
6625-00-908-7392	5	11	5310-00-938-2013	28	16
6625-00-908-7393	5	2	5310-00-938-2013	29	17
6625-00-908-7394	12	41	5310-00-938-2013	30	16
5355-00-908-7395	12	44	5310-00-938-2013	31	7
6625-00-908-7396	12	52	5140-00-944-7205	4	8
6625-00-908-7397	12	21	5140-00-944-7206	4	7
6625-00-908-7399	12	22	5930-00-944-9835	18	27
5355-00-908-7400	12	45	5930-00-944-9836	18	30
6625-00-908-7401	5	48	5930-00-944-9837	18	11
5355-00-909-0465	5	21	5930-00-944-9838	18	32
5355-00-909-0465	18	5	5950-00-944-9906	15	51
5305-00-909-1949	24	13	5340-00-946-9442	23	2
5305-00-909-1949	25	13	5930-00-947-1925	12	7
5305-00-909-1949	26	27	3040-00-950-9578	12	46
5305-00-909-1949	27	15	5935-00-951-9331	12	3
5305-00-909-1949	27	12	5935-00-951-9331	15	26
5305-00-909-1949	29	14	5120-00-952-0108	4	11
5305-00-909-1949	30	14	5961-00-954-2159	9	2
5305-00-909-1949	31	14	5961-00-954-4864	10	12
5940-00-914-9911	10	72	5905-00-954-6432	18	20
5940-00-916-2776	11	9	5905-00-954-6899	18	26
5940-00-916-2776	13	16	5935-00-959-1457	4	15
5310-00-924-8526	5	77	5120-00-963-7661	4	2
5310-00-928-2690	1	9	6625-00-965-1483	1	5
5310-00-928-2690	1	15	5935-00-969-6996	5	27
5310-00-928-2690	5	63	5935-00-969-6996	15	25
5310-00-928-2690	5	92	5935-00-969-6996	15	30
5310-00-928-2690	12	31	5905-00-975-1128	13	33
5310-00-928-2690	15	1	5340-00-975-1440	5	58
5310-00-928-2690	18	17	5305-00-978-9343	12	35
5310-00-928-2690	24	9	6625-00-985-8078	3	5
5310-00-928-2690	25	7	6625-00-985-8079	3	6
5310-00-928-2690	27	32	6625-00-985-8080	3	7
5310-00-928-2690	28	9	5995-00-985-8081	3	4
5310-00-928-2690	29	0	6625-00-985-8082	3	17
5310-00-928-2690	30	12	6625-00-985-8083	3	2
5310-00-928-2690	31	25	6625-00-985-8084	3	16
5935-00-928-3127	19		6625-00-985-8085	3	15
5310-00-929-1748	35	4	6625-00-985-8086	3	14
5310-00-929-1748	37	34	6625-00-985-8088	3	12
5310-00-929-1748	39	5	5905-00-990-0018	13	27
5310-00-929-6395	1	36	5905-00-990-2912	9	24
5310-00-929-6395	5	43	5935-00-990-6983	4	21
5310-00-929-6395	12	57	5935-00-993-2181	24	20
5310-00-929-6395	13	12	5935-00-993-2181	26	15
5310-00-929-6395	15	15	5935-00-993-2181	28	18
5310-00-929-6395	18	34	5935-00-993-2181	29	2

SECTION IV

NATIONAL STOCK NUMBER AND PART NUMBER INDEX

STOCK NUMBER	FIGURE NO	ITEM NO	STOCK NUMBER	FIGURE NO	ITEM NO		
5935-00-993-2181	37	5	5935-01-029-7458	35	6		
5950-00-999-7257	7	5	5935-01-035-5650	3	9		
PART NUMBER	FSCM	FIG NO	ITEM NO	PART NUMBER	FSCM	FIG NO	ITEM NO
A3396-2A	12615	11	6	DAMF11W1S	71468	25	8
A3397-1A	12615	10	35	DAMF11W1S	71468	25	8
AB397-1A	12615	11	23	DAMF11W1S	71468	36	1
AB406D	12615	6	24	DAMF3W3S	71468	26	19
AB406D	12615	7	5	DAM11W1P	71468	25	17
AB406D	12615	9	1	DAM11W1P	71468	27	5
AB406D	12615	12	65	DAM11W1P	71468	36	2
AB406D	12615	13	19	DAM3W3P	71468	26	32
AB406D	12615	16	6	DA15P	71468	24	7
AB406D	12615	17	15	DA15P	71468	26	33
AS1484ARC51X	80058	1	4	DA15P	71468	28	10
A14666	70674	7	15	DA15P	71468	29	19
A14667	70674	6	31	DA15P	71468	37	6
BR7X300D2S3-26V	82050	5	68	DA397ARC51X	80058	1	3
BWH1R0J	75042	10	54	DBMF13W3S	71468	30	18
CA5123-1	71468	31	22	DBMF13W3S	71468	38	1
CA53693-78	71468	34	1	DBM13W3P	71468	30	8
CA53693-79	71468	33	1	DBM13W3P	71468	38	2
CA53693-80	71468	32	1	DBM25P	71468	35	6
CBL3BC107M	81349	6	45	DEF9S	71468	31	26
CC20CH050D	81349	11	17	DEF9S	71468	39	
CC20CH070D	81349	10	52	DE9P	71468	31	6
CC20CK010D	81349	11	27	DE9P	71468	39	7
CC20RJ030D	81349	11	42	DF30BC	58474	15	22
CETC6B	71468	4	2	DF30RC	58474	15	19
CG1889U5FT	80058	3	3		58474		
CG3118ARC51X	80058	3	5		58474		
CG3119ARC51X	80058	3	6	DM53740-5000	71468	25	10
CG3120ARC51X	80058	3	7	DM53740-5000	71468	26	26
CK05CW102M	81349	10	4	DM53740-5000	71468	27	4
				DM53740-5000	71468	30	7
CL25BH111UP3	81349	13	8	DM53740-5000	71468	31	5
				DM53742-5000	71468	25	16
CM05C050K03	81349	11	33	DM53742-5000	71468	26	20
CM05ED360G03	81349	11	35	DM53742-5000	71468	27	29
				DM53742-5000	71468	30	1
CM06F102J03	81349	8	17	DM53742-5000	71468	31	27
CM06F471J03	81349	6	38	E4190R1	44655	5	76
CM06F471J03	81349	11	14	F10-1	26848	4	6
CM06F471J03	81349	17	32				
CR068	80223	6	43	F22NA1K82	72962	5	61
CR068	80223	7	11	F22NCFM1-40	72962	10	20
CS13BB157M	81349	17	30	F22NCFM1-40	72962	11	11
CS13BB476M	81349	6	46	GT1003	70276	4	11
CS13BB476M	81349	17	31				
CS13BD106M	81349	6	6	HP6N	09922	5	58
CS13BD106M	81349	8	13	HP8N	09922	5	47
CS13BD106M	81349	17	5	IMC302	10583	6	42
CS13BE156M	81349	6	37	IMC302	10583	8	7
				JAN1N538	81350	12	2
				JAN1N538	81350	15	59
				JAN1N547	81350	13	28
CS13BF225M	81349	15	62	JAN1N647	81349	5	40
CS13BF476M	81349	12	4	JAN1N647	81349	5	82
CS13BF685M	21349	6	32	JAN1N647	81349	15	64
CS13BF685M	81349	8	18				
CS13BF685M	81349	17	21	MP206-2B	95105	13	10
CW710ARC51X	80058	1	6	MS122119	96906	24	17
CX10185ARC51X	80058	3	16	MS122119	96906	25	9
				MS122119	96906	26	28
CX10187ARC51X	80058	3	15	MS122119	96906	27	14
CX10188ARC51X	80058	3	14	MS122119	96906	28	15
CX10189ARC51X	80058		13	MS122119	96906	29	13
CX10190ARC51X	80058	3	12	MS122119	96906	30	9
CX10191ARC51X	80058	3	4	MS122119	96906	31	13
CX9052ARC51X	80058	3	17	MS16108-2A	96906	15	33
CX9053ARC51X	80058	3	2	MS16562-189	96906	24	16
DAF15S	71468	24	20	MS16562-189	96906	25	24
DAF15S	71468	26	15	MS16562-189	96906	26	23
DAF15S	71468	28	18	MS16562-189	96906	27	25
DAF15S	71468	29	2	MS16562-189	96906	28	14
DAF15S	71468	37	5	MS16562-189	96906	29	12

SECTION IV

NATIONAL STOCK NUMBER AND PART NUMBER INDEX

PART NUMBER	FSCM	FIG NO	ITEM NO	PART NUMBER	FSCM	FIG NO	ITEM NO
MS16562-189	96906	30	5	MS35649-24	96906	31	7
MS16562-189	9609	31	21	MS35649-44	96906	6	20
MS16997-10	96906	12	35	MS35650-104	96906	10	41
MS171444	96906	4	22	MS51957-1	96906	18	6
MS171444	96906	5	104	MS51957-1	96906	23	29
MS171444	96906	15	73	MS51957-1	96906	24	4
MS18130-2	96906	16	15	MS51957-1	96906	25	11
MS18130-3	96906	11	16	MS51957-1	96906	26	25
MS18130-4	96906	11	37	MS51957-1	96906	27	17
MS18130-6	96906	11	18	MS51957-10	96906	12	5
MS18130-8	96906	11	16	MS51957-12	96906	6	40
MS21044D04	96906	5	55	MS51957-12	96906	10	48
MS21044D06	96906	5	59	MS51957-12	96906	11	10
MS25089-4C	96906	5	71	MS51957-12	96906	23	31
MS25237-327	96906	5	16	MS51957-12	96906	26	4
MS25237-327	96906	12	40	MS51957-12	96906	27	20
MS25237-327	96906	15	2	MS51957-12	96906	30	20
MS3112E16-26P	96906	21	2	MS51957-12	96906	31	17
MS3112E16-26PW	96906	20	2	MS51957-13	96906	5	66
MS3112E18-32P	96906	15	16	MS51957-13	96906	7	10
MS3114E12-3P	96906	15	36	MS51957-13	96906	7	13
MS3114E16-26P	96906	5	31	MS51957-13	96906	13	35
MS3114E16-26P	96906	15	5	MS51957-13	96906	17	23
MS3114E16-26PW	96906	12	3	MS51957-13	96906	20	3
MS3114E16-26PW	96906	15	26	MS51957-13	96906	21	3
MS3116F12-3S	96906	40	2	MS51957-14	96906	1	30
MS3116F18-32S	96906	41	2	MS51957-14	96906	5	28
MS35058-31	96906	15	42	MS51957-14	96906	7	2
MS35059-23	96906	15	43	MS51957-14	96906	9	20
MS35059-30	96906	5	73	MS51957-14	96906	13	6
MS35168-88E	96906	5	50	MS51957-14	96906	15	50
MS35168-88E	96906	5	51	MS51957-14	96906	15	55
MS35168-88E	96906	15	17	MS51957-14	96906	23	9
MS35201-53	96906	5	34	MS51957-15	96906	12	42
MS35201-53	96906	15	41	MS51957-15	96906	23	28
				MS51957-16	96906	23	27
				MS51957-17	96906	2	4
MS35214-16	96906	5	12	MS51957-17	96906	5	37
MS35333-70	96906	1	17				
MS35333-73	96906	10	43				
MS35338-134	96906	1	9	MS51957-19	96906	23	21
MS35338-134	96906	1	15	MS51957-2	96906	1	8
MS35338-134	96906	5	3	MS51957-2	96906	10	23
MS35338-134	96906	5	92	MS51957-2	96906	15	58
MS35338-134	96906	12	31	MS51957-20	96906	5	42
MS35338-134	96906	15	71	MS51957-26	96906	5	42
MS35338-134	96906	18	7	MS51957-26	96906	12	63
MS35338-135	96906	1	31	MS51957-26	96906	13	11
MS35338-135	96906	5	67	MS51957-27	96906	10	37
MS35338-135	96906	6	11	MS51957-27	96906	15	45
MS35338-135	96906	6	1	MS51957-27	96906	8	15/
MS35338-135	96906	6	41	MS51957-27	96906	18	15
MS35338-135	96906	7	3	MS51957-27	96906	24	22
MS35338-135	96906	7	14	MS51957-27	96906	25	4
MS35338-135	96906	12	33	MS51957-27	96906	26	11
MS35338-135	96906	13	36	MS51957-27	96906	27	9
MS35338-135	96906	17	25	MS51957-27	96906	28	5
MS35338-135	96906	23	321	MS51957-27	96906	29	6
MS35338-136	96906	1	36	MS51957-27	96906	30	24
MS35338-136	96906	5	43	MS51957-27	96906	31	30
MS35338-136	96906	12	57	MS51957-28	96906	1	35
MS35338-136	96906	13	2	MS51957-28	96906	5	95
MS35338-136	96906	15	5	MS51957-28	96906	9	5
MS35338-136	96906	18	34	MS51957-28	96906	15	14
MS35367-913A	96906	15	28	MS51957-28	96906	18	2
MS35489-4	96906	7	12	MS51957-3	96906	12	30
MS35489-4	96906	23	3	MS51957-3	96906	13	18
MS35649-24	96906	1	12	MS51957-4	96906	1	13
MS35649-24	96906	1	20	MS51957-4	96906	5	105
MS35649-24	96906	5	60	MS51957-4	96906	15	70
MS35649-24	96906	5	90	MS51957-4	96906	15	70
MS35649-24	96906	5	0	MS51957-4	96906	35	3
MS35649-24	96906	10	8	MS51957-4	96906	37	7
MS35649-24	96906	12	36	MS51957-4	96906	34	4
MS35649-24	96906	15	11	MS51957-47	96906	1	26
MS35649-24	96906	18	13	MS51957-5	96906	10	31
MS35649-24	96906	24	10	MS51957-5	96906	12	39
MS35649-24	96906	25	18	MS51957-6	96906	5	91
MS35649-24	96906	26	16	MS51957-8	96906	12	73
MS35649-24	96906	27	6	MS51959-12	96906	23	26
MS35649-24	96906	28	16	MS51959-13	96906	5	96
MS35649-24	96906	29	17	MS51959-13	96906	13	15
MS35649-24	96906	30	16	MS51959-14	96906	5	56

SECTION IV

NATIONAL STOCK NUMBER AND PART NUMBER INDEX

PART NUMBER	FSCM	FIG NO	ITEM NO	PART NUMBER	FSCM	FIG NO	ITEM NO
MS51959-14	96906	12	34	P343-0285-00	77250	16	9
MS51959-14	96906	23	4	P343-0287-00	77203	5	24
MS51959-2	96906	1	27	P343-0287-00	11	41	
MS51959-2	96906	11	7	P343-0287-00	77250	15	5
MS51959-27	96906	18	16	P343-0288-00	77250	5	24
MS51959-28	96906	1	33	P343-0288-00	77250	15	7
MS51959-3	96906	24	19	P343-0330-00	77250	13	31
MS51959-3	96906	25	19	RC07GF100K	81349	10	16
MS51959-3	96906	26	30	RC07GF101J	81349	10	68
MS51959-3	96906	27	7	RC07GF101J	81349	11	30
MS51959-3	96906	28	17	RC07GF102K	81349	10	76
MS51959-3	96906	29	18	RC07GF102K	81349	11	26
MS51959-3	96906	30	17	RC07GF103K	81349	10	57
MS51959-3	96906	31	8	RC07GF122K	81349	10	27
MS51959-3	96906	35	7	RC07GF182K	81349	10	67
MS51959-3	96906	37	3	RC07GF183J	81349	10	63
MS51959-3	96906	39	6	RC07GF2R7J	81349	10	47
MS51959-4	96906	5	62	RC07GF221K	81349	10	73
MS51959-4	96906	15	12	RC07GF221K	81349	11	22
MS51959-4	96906	18	14	RC07GF222K	81349	10	60
MS51959-5	96906	24	8	RC07GF224J	81349	11	31
MS51959-5	96906	25	6	RC07GF332K	81349	10	15
MS51959-5	96906	26	17	RC07GF471J	81349	10	66
MS51959-5	96906	27	30	RC07GF473K	81349	11	29
MS51959-5	96906	28	7	RC07GF560K	81349	10	21
MS51959-5	96906	29	8	RC07GF820K	81349	10	17
MS51959-5	96906	30	10	RC20GF100J	81349	6	16
MS51959-5	96906	31	23	RC20GF100J	81349	8	10
MS51981-16	96906	12	43	RC20GF102J	81349	5	49
MS51981-26	96906	5	4	RC20GF102J	81349	6	35
MS51981-26	96906	18	8	RC20GF102J	81349	17	9
MT3371ARC51X	80058	1	6	RC20GF102K	81349	16	12
MT3372ARC51X	80058	1	2	RC20GF104J	81349	5	45
MX4906ARC51X	80058	23	14	RC20GF122J	81349	6	30
MX4907ARC51X	80058	23	16	RC20GF123J	81349	6	7
MX4908ARC51X	80058	23	13	RC20GF123J	81349	8	11
MX4909ARC51X	80058	23	12	RC20GF151J	81349	17	27
MX4910ARC51X	80058	23	18	RC20GF151K	81349	15	40
MX4911ARC51X	80058	23	11	RC20GF151K	81349	18	25
MX4912ARC51X	80058	23	17	RC20GF153J	81349	6	4
MX4913ARC51X	80058	23	15	RC20GF153J	81349	8	6
MX6731ARC51X	80058	2	6	RC20GF153J	81349	15	63
MX6732ARC51X	80058	2	3	RC20GF153J	81349	17	26
MX6733ARC51X	80058	2	1	RC20GF180K	81349	13	34
MX6734ARC51X	80058	2	2	RC20GF183K	81349	16	16
				RC20GF222J	81349	6	34
M23-1000M	83021	11	2	RC20GF222J	81349	8	5
M9-6884-00	13855	10	36	RC20GF222J	81349	17	6
M9-6884-00	13855	11	38	RC20GF242J	81349	15	65
NM06127M3J	43334	12	51	RC20GF271J	81349	6	6
NP9	08730	23	6	RC20GF272J	81349	6	27
NX24427	71450	18	26	RC20GF272J	81349	8	1
NX24428	71450	5	35	RC20GF272J	81349	17	8
NX24429	71450	18	20	RC20GF272K	81349	6	5
PSA2	82647	5	94	RC20GF602J	81349	8	2
P106E16-26SSR	77820	44	3	RC20GF330J	81349	17	7
PT06E16-26SWSR	77820	43	3	RC20GF331J	81349	8	14
P313-0051-00	77250	5	23	RC20GF332J	81349	11	1
P313-0051-00	77250	15	6	RC20GF391J	81349	6	19
P313-0132-00	77250	5	53	RC20GF393J	81349	6	28
P313-0132-00	77250	5	65	RC20GF471J	81349	8	12
P313-0132-00	77250	6	39	RC20GF560J	81349	6	29
P313-0132-00	77250	7	9	RC20GF561J	81349	6	3
P313-0132-00	77250	12	67	RC20GF561J	81349	17	2
P313-0132-00	77250	15	53	RC20GF562J	81349	6	2
P313-0132-00	77250	17	11	RC20GF562J	81349	8	15
P313-0132-00	77250	23	20	RC20GF562J	81349	17	3
P313-0156-00	77250	11	40	RC2CGF681K	81349	10	64
P330-2284-00	77250	10	24	RC20GF820K	81349	9	15
P334-0266-00	77250	6	17	RC20GF822J	81349	5	44
P334-0266-00	77250	17	18	RC32GF151K	81349	9	16
P334-0287-00	77250	5	77	RC32GF271J	81349	17	28
P334-4120-00	77250	5	29	RC32GF391K	81349	11	20
P334-4120-00	77250	18	21	RC42GF151K	81349	18	24

SECTION IV

NATIONAL STOCK NUMBER AND PART NUMBER INDEX

PART NUMBER	FSCM	FIG NO	ITEM NO	PART NUMBER	FSCM	FIG NO	ITEM NO
RC42GF390K	81349	9	19	T6009	71124	41	1
RC42GF393K	81349	13	26	T6010	71124	43	1
RC42GF683K	81349	13	25	T6010	71124	44	1
RG213U	80058	42	1	UG109BU	80058	10	53
RG303U	81349	26	36	UG21E/U	80058	19	1
RG58CU	80058	15	24	UG21EU	80058	42	2
RG58CU	80058	15	29				
RH50-2R000G	91637	5	93	UG625BU	80058	16	11
RN70C1102F	81349	5	85	U334ARC51X	80058	3	11
RN70C1212F	81349	5	98	U335ARC51X	80058	3	8
RN70C2372F	81348	5	99	U336ARC51X	80058	3	9
RN70C2373F	81349	5	84	VC20GY	73899	10	11
RN70C2872F	81349	5	100	VC20GY	73899	11	21
RN70C3833F	81349	5	86	VC951	73899	10	1
RN70C4223F	81349	5	81				
RN70C8251F	81349	5	101	024-0168-00	13499	4	17
RV5LAYSB253B	81349	6	15	024-0628-010	13499	4	26
RV5LAYSB253B	81349	17	20	024-0628-020	13499	4	3
RW59VR10	81349	9	23	024-0642-010	13499	4	9
RW67VL51	81349	5	80	024657-0000	71468	39	2
RW67VL51	81349	9	12	024658-0000	71468	37	1
RW67V221	81349	13	27	052-0512	98278	26	35
RW67V331	81349	13	24	1A1S4H2	79807	5	75
RW69V2R7	81349	9	24	1A1S4H2	79807	15	48
RW69V391	81349	13	33	1N2984B	81349	9	18
RY4N4B3L	81349	5	89	1N3029B	80131	5	83
R3484)3-32	12014	13	13	1N645	81349	10	18
SDA3K01104M	53021	5	87				
SKT10WHT	98291	4	20				
SKT41RED	98291	24	21				
SKT41RED	98291	26	2	1N963B	81349	10	65
SKT41RED	98291	27	2	1N973B	81349	10	74
SKT41RED	98291	29	20	1P4-26A	86577	10	2
SKT41RED	98291	31	2	100-200-16-23	99378	13	14
SL124-198	12615	13	23	101N3100A25	94375	5	27
SL158-198	12615	10	46	101N3100A25	94375	15	25
SL158-198	12615	15	61	101N3100A25	94375	15	30
SL158-198	12615	17	14	1025-08	99800	10	14
SL173-197	12615	13	22	1025-12	99800	10	28
SL173-197	12615	15	66	108-56	02374	12	41
SL173-197	12615	16	4	136A146	25140	12	58
SL174-198	12615	6	23	15517	76854	12	6
SL174-198	12615	9	22	15523-1-4	76854	12	10
SL174-198	12615	12	70	15523-3-8	76854	12	8
SL179-230	12615	10	38	1714-05	78189	5	79
SL180-231	12615	10	19	1714-05CADPL	78189	6	18
SL283-230	12615	11	4	1714-05CADPL	78189	17	19
SL314-231	12615	11	9				
SL314-231	12615	13	16				
SL354-351DWHT	12615	10	55				
SL441-434DWHT	12615	10	39	2L2FF	96881	12	14
SM3-15-2-50VDC	74193	15	37	2N1100	07688	13	5
SM348AARC51X	80058	1	1	2N1165	81349	9	2
SM348ARC51X	80058	1	1	2N1485	80131	9	8
SS5170	86577	10	72	2N3026	04713	9	9
				2N3375	80131	10	44
TF300	98291	10	40	2N3866	07688	10	12
TF300	98291	12	71	2N918	81349	10	75
TK155ARC51X	80058	1	7	203B	83330	4	21
TS0205C01	81349	10	33	2102	86577	5	10
TS0205C01	81349	11	34	2102	86577	15	1
TS1962ARC51X	80058	1	5	2104-04-01-2520N	78189	15	52
TXB2P032-037-3	98978	6	13	2104-06-02-2520N	78189	13	30
TXB2P032-037-3	98978	8	8	212-12	71286	15	10
T1533	98291	10	77	236922BA1	76854	18	32
T1571	98291	8	4	236923BA1	76854	18	27
T3-361	98978	11	12	237164RK1	76854	18	11
T3-491	98978	11	4	237617BA3	76854	5	39
T5975	71124	40	1	238191RK2	76854	18	30

SECTION IV

NATIONAL STOCK NUMBER AND PART NUMBER INDEX

PART NUMBER	FSCM	FIG NO	ITEM NO	PART NUMBER	FSCM	FIG NO	ITEM NO
				334-1656-00	06164	1	24
243888A	76854	12	72	340-0642-00	91314	1	22
244494A	76854	12	9	340-0642-00	91314	12	61
245476A	76854	12	7	340-0642-00	91314	24	12
2482-00W5R0501M	72982	10	13	340-0642-00	91314	25	14
26BLK	76545	40	7	340-0642-00	91314	26	29
				340-0642-00	91314	27	13
2600-8	71286	18	3	340-0642-00	91314	28	11
2600SW2	13499	18	4	340-0642-00	91314	29	15
3 2FF	96881	12	27	340-0642-00	91314	30	13
3SAF1241	01526	12	64	340-0642-00	91314	31	12
302-0622-000	05284	10	29	340-0644-000	91314	2	5
302-0622-000	05284	11	39	36677	73386	6	22
306-0983-000	86577	10	71	36677	73386	17	13
310-0045-00	79807	5	38	36681	73386	13	4
310-0045-00	79807	6	21	37053	73386	13	7
310-0045-00	79807	15	54	37346	73386	7	8
310-0045-00	79807	17	12	37346	73386	17	1
310-0046-00	79807	9	6				
310-0046-00	79807	18	33	374NF0125DEGC4PPFORM25PF	72982	10	6
310-0049-000	79807	10	42	374NF0125DEGC5PPFF	72982	10	3
310-0053-00	79807	10	9	374NF1025DEGC4PPFORM25PF	72982	10	70
310-0054-00	79807	9	14	4007-6	77147	5	72
310-0070-000	79807	24	9	4007-6	77147	15	47
310-0070-000	79807	25	7				
310-0070-000	79807	27	32	4021	77147	13	1
310-0070-000	79807	28	9	4021	77147	15	21
310-0070-000	79807	29	10	4040-2HDSPL	77147	10	34
310-0070-000	79807	30	12	4090	77147	16	1
310-0070-000	79807	31	25	4161F	70998	5	41
310-0071-000	79807	24	23	432H4	10646	13	29
310-0071-000	79807	25	5	476-0386-000	13499	5	11
310-0071-000	79807	26	12	5005-62	79136	5	8
310-0071-000	79807	27	10	502-1515-002	13499	17	24
310-0071-000	79807	28	6	505-1504-001	13499	5	14
310-0071-000	79807	29	7	505-1504-001	13499	15	38
310-0071-000	79807	30	25	505-1504-001	13499	18	22
310-0071-000	79807	31	31	51-258	98278	26	7
310-0074-00	79807	7	7	5133-18C	79136	12	26
310-0074-00	79807	9	11	5133-18C	79136	12	29
310-0074-00	79807	11	8	53-315	98278	26	9
310-0075-00	79807	6	26	540-9002-003	13499	15	56
310-0075-00	79807	10	22	540-9003-003	13499	10	25
310-0075-00	79807	12	68	540-9041-003	13499	7	4
310-0075-00	79807	13	21	540-9041-003	13499	17	22
310-0075-00	79807	16	7	540-9059-003	13499	5	30
310-0075-00	79807	17	17	540-9168-003	13499	23	25
				541-1233-003	13499	12	48
				541-5187-002	13499	5	36
				541-5950-002	13499	5	88
				541-5987-002	13499	23	22
310-0079-000	13499	40	4	541-5991-002	13499	6	10
310-0080-00	79807	13	3	542-1560-003	13499	5	78
				542-4510-002	13499	12	19
310-0129-00	05411	35	4	542-4524-002	13499	12	25
310-0129-00	05411	37	4	542-4525-002	13499	12	23
310-0129-00	05411	39	5	542-4560-002	13499	12	20
310-0278-000	70318	20	4	542-4723-003	13499	12	15
310-0278-000	70318	21	4	544-8352-002	13499	4	15
310-0278-000	70318	26	5	544-8357-002	13499	4	27
310-0278-000	70318	27	21	544-8398-002	13499	4	10
310-0278-000	70318	30	21	546-5174-002	13499	12	24
310-0278-000	70318	31	16	546-8921-003	13499	12	16
310-0400-00	79807	16	3	547-1643-002	13499	1	25
310-6320-000	79807	1	14	547-1646-002	13499	1	18
310-6320-000	79807	12	37	547-1647-002	13499	1	23
310-6320-000	79807	18	16	547-5305-002	13499	5	69
310-6320-000	79807	24	18	547-5305-002	13499	15	32
310-6320-000	79807	25	20	548-2214-002	13499	4	23
310-6320-000	79807	26	31	548-4713-003	13499	12	22
310-6320-000	79807	27	31	548-9286-002	13499	4	18
310-6320-000	79807	28	8	549-3484-002	13499	12	38
310-6320-000	79807	29	9	549-3662-002	13499	30	29
310-6320-000	79807	30	11	549-3856-002	13499	26	38
310-6320-000	79847	31	24	549-3856-002	13499	27	23
310000070000	79807	26	18	549-3856-002	13499	31	19
31902	00779	40	3	549-6021-002	13499	12	46
323-0264-000	74545	12	50	553-9709-002	13499	4	25
327-029X5T0102Z	72982	16	17	6A49450	53800	4	14
32867	80089	15	51	6018-124CN	91506	23	2

TM11-6625-564-40P
SECTION IV
NATIONAL STOCK NUMBER AND PART NUMBER INDEX

PART NUMBER	FSCM	FIG NO	ITEM NO	PART NUMBER	FSCM	FIG NO	ITEM NO
6019-41CN	91506	23	8	756-8952-002	13499	24	1
6020-11CN	91506	23		756-8952-002	13499	28	4
6111WA	81349	11	43	756-8958-001	13499	28	3
				756-8958-001	13499	30	26
63-1660-26	72962	10	30	756-8963-001	13499	30	23
68-1660-26	72962	35	2	756-8964-001	13499	30	22
68-1660-26	72962	37	2	756-8967-001	13499	30	6
68-1660-26	72962	39	3	756-8969-001	13499	24	2
68-1660-40	72962	9	13	756-8970-001	13499	24	6
713-0055-010	13499	22	1	756-8978-001	13499	25	1
7229	17875	4	16	756-8982-002	13499	25	3
7274775	16758	9	3	756-8985-001	13499	25	2
756-7571-001	13499	4	24	756-9020-001	13499	23	23
756-7579-001	13499	4	5	756-9021-001	13499	23	10
756-7580-001	13499	4	4	756-9024-001	13499	23	1
756-8791-001	13499	10	26	756-9032-001	13499	23	19
756-8791-001	13499	11	28	756-9043-001	13499	1	21
756-8792-001	13499	11	19	756-9050-001	13499	1	37
756-8792-002	13499	11	13	756-9051-001	13499	1	29
756-8834-001	13499	15	46	756-9054-001	13499	1	28
756-8834-002	13499	18	18	756-9057-001	13499	1	10
756-8835-001	13499	15	44	756-9058-001	13499	1	34
756-8835-002	13499	18	28	756-9059-001	13499	1	32
756-8837-002	13499	18	29	756-9112-001	13499	6	8
756-8841-001	13499	18	9	756-9136-001	13499	9	21
756-8846-001	13499	18	10	756-9151-001	13499	13	17
756-8871-001	13499	15	13	756-9173-001	13499	12	47
756-8875-001	13499	16	10	756-9176-001	13499	12	18
756-8876-001	13499	5	19	756-9177-001	13499	12	62
756-8876-001	13499	15	23	756-9184-001	13499	12	53
756-8885-001	13499	5	102	756-9185-001	13499	12	13
756-8885-001	13499	15	68	756-9189-001	13499	12	52
756-8886-001	13499	5	103	756-9193-001	13499	12	54
756-8886-001	13499	15	74	756-9195-001	13499	12	12
756-8887-001	13499	15	69	756-9196-001	13499	12	32
756-8889-001	13499	5	106	756-9197-001	13499	12	11
756-8889-001	13499	15	72	756-9198-001	13499	12	49
756-8890-001	13499	15	67	756-9206-001	13499	5	70
756-8902-001	13499	29	5	756-9207-001	13499	5	7
756-8905-001	13499	29	3	756-9208-001	13499	5	6
756-8905-002	13499	29	4	756-9211-001	13499	5	52
756-8911-001	13499	27	12	757-0228-001	13499	5	21
756-8916-001	13499	27	8	757-0228-001	13499	18	5
756-8916-002	13499	27	11	757-0230-001	13499	5	3
756-8922-001	13499	26	3	757-0231-001	13499	18	1
756-8922-001	13499	27	19	757-9783-000	13499	1	11
756-8922-001	13499	30	19	761-0012-003	13499	5	74
756-8922-001	13499	31	18	761-0012-003	13499	15	4
756-8923-001	13499	31	28	761-5944-001	13499	4	1
756-8924-001	13499	24	13	761-5945-001	13499	4	8
756-8924-001	13499	25	13	761-5947-001	13499	4	7
756-8924-001	13499	26	27	761-5949-001	13499	5	97
756-8924-001	13499	27	15	761-5950-001	13499	43	2
756-8924-001	13499	28	12	761-5950-001	13499	44	2
756-8924-001	13499	29	14	761-7002-001	13499	31	9
756-8924-001	13499	30	14	761-7003-001	13499	30	15
756-8924-001	13499	31	14	761-7003-001	13499	31	3
756-8925-001	13499	31	29	761-7003-002	13499	25	15
756-8925-002	13499	31	32	761-7003-002	13499	26	21
756-8926-001	13499	26	39	761-7003-002	13499	27	27
756-8926-001	13499	27	22	761-7005-001	13499	30	2
756-8926-001	13499	30	30	761-7006-002	13499	26	37
756-8926-001	13499	31	10	761-7006-002	13499	27	18
756-8927-001	13499	26	22	761-7006-002	13499	30	28
756-8927-001	13499	27	26	761-7006-002	13499	31	15
756-8927-001	13499	30	4	761-7008-001	13499	29	16
756-8927-001	13499	31	20	761-7010-001	13499	28	19
756-8927-002	13499	24	15	761-7012-001	13499	27	3
756-8927-002	13499	25	23	761-7014-001	13499	26	34
756-8927-002	13499	28	13	761-7016-001	13499	25	21
756-8927-002	13499	29	11	761-7018-001	13499	24	11
756-8928-001	13499	26	14	761-7019-001	13499	21	1
756-8929-001	13499	30	27	761-7020-001	13499	20	1
756-8933-001	13499	31	4	761-7024-001	13499	5	9
756-8936-001	13499	26	8	761-7025-001	13499	23	5
756-8937-001	13499	26	10	761-7026-001	13499	23	3
756-8942-001	13499	26	6	761-7029-001	13499	12	56
756-8942-002	13499	26	13	761-7029-002	13499	13	37
756-8952-001	13499	24	3	761-7029-003	13499	14	5
756-8952-001	13499	28	2	761-7029-004	13499	6	33

TM11-6625-564-40P
SECTION IV
NATIONAL STOCK NUMBER AND PART NUMBER INDEX

PART NUMBER	FSCM	FIG NO	ITEM NO	PART NUMBER	FSCM	FIG NO	ITEM NO
791-7029-004	13499	17	10	761-7074-001	13499	15	18
761-7030-001	13499	5	32	761-7075-001	13499	15	49
761-7032-001	13499	5	54	761-7078-001	13499	18	31
751-7034-001	13499	5	48	761-7317-001	13499	12	59
761-7035-001	13499	15	9	761-7318-001	13499	12	28
761-7036-001	13499	5	46	761-7319-001	13499	12	60
761-7037-001	13499	5	57	767-0745-000	13499	18	7
761-7039-001	13499	6	1	767-0747-010	13499	24	14
761-7040-001	13499	5	18	767-0748-010	13499	25	12
761-7041-001	13499	5	20	767-0754-008	13499	1	19
761-7042-001	13499	5	13	767-0758-010	13499	26	24
761-7043-001	13499	5	2	767-0759-010	13499	27	16
761-7044-001	13499	5	1	767-0764-008	13499	23	30
761-7047-001	13499	7	1	767-7540-001	13499	10	7
761-7057-001	13499	12	45	767-7558-001	13499	10	61
761-7057-002	13499	12	44	775-2711-001	13499	5	1
761-7058-001	13499	12	17	775-2747-001	13499	10	45
761-7059-001	13499	12	21	775-2748-001	13499	10	10
761-7060-001	13499	12	1	775-2750-001	13499	10	69
761-7061-001	13499	12	66	775-2754-001	13499	10	32
761-7062-001	13499	5	5	8185	94991	11	5
761-7064-001	13499	14	1	85502 OR	08717	5	17
761-7065-001	13499	14	4	855020R	08717	15	3
761-7066-001	13499	14	2	855029-9	08717	5	22
761-7069-001	13499	14	3	855029-9	08717	15	34
761-7071-001	13499	15	57	997F18	10646	10	58
761-7072-001	13499	15	0	997F41	10646	10	56
761-7073-001	13499	15	27				

LATEST NATIONAL STOCK NUMBER ASSIGNMENTS

STOCK NUMBER	FIG NO	ITEM NO	STOCK NUMBER	FIG NO	ITEM NO
5910-00-022-2760	10	50	5330-00-824-9130	31	11
5310-00-050-6833	10	20	5961-00-837-7262	6	14
5310-00-050-6833	11	11	5961-00-837-7262	8	16
5305-00-054-5651	12	55	5961-00-837-7262	17	4
5310-00-058-2949	20	4	5961-00-837-9287	17	29
5310-00-058-2949	21	4	3120-00-839-3921	12	14
5310-00-058-2949	26	5	5961-00-850-9564	9	17
5310-00-058-2949	27	21	5365-00-857-1960	5	8
5310-00-058-2949	30	21	5310-00-881-1624	1	24
5310-00-058-2949	31	16	5935-00-883-0218	35	5
5910-00-060-1189	16	14	5905-00-910-9485	15	31
5910-00-063-8428	10	59	5925-00-918-3023	5	33
5305-00-071-1321	23	7	5306-00-924-0654	1	18
6145-00-080-6517	16	5	5310-00-934-9740	6	25
6145-00-080-6517	26	36	5310-00-934-9740	7	6
5910-00-089-7504	10	62	5310-00-934-9740	9	10
5910-00-134-0623	13	9	5310-00-934-9740	11	24
5310-00-184-8977	13	32	5310-00-934-9740	12	69
5310-00-184-8996	5	26	5310-00-934-9740	13	20
5310-00-184-8996	9	7	5310-00-934-9740	16	8
5310-00-184-8996	15	8	5310-00-934-9740	17	16
5120-00-198-5401	4	13	5310-00-934-9761	9	4
5310-00-261-8278	15	20	5310-00-934-9766	13	2
5910-00-276-6901	11	3	5940-00-941-1933	40	5
5975-00-281-0034	40	6	5940-00-950-5760	10	39
5325-00-285-3373	18	12	5940-00-950-5761	10	55
5910-00-489-7610	10	51	5935-00-954-4470	24	5
5940-00-552-4531	11	32	5935-00-954-4470	25	22
5961-00-556-2091	16	13	5935-00-954-4470	26	1
1270-00-612-4041	10	5	5935-00-954-4470	27	1
5935-00-617-6837	4	20	5935-00-954-4470	28	1
5310-00-639-7435	18	4	5935-00-954-4470	29	1
5935-00-643-9875	3	10	5935-00-954-4470	30	3
5310-00-685-7739	16	2	5935-00-954-4470	31	1
5940-00-702-3517	10	49	5310-00-981-2255	7	7
5365-00-717-8566	2	5	5310-00-981-2255	9	11
5935-00-722-4350	35	1	5310-00-981-2255	11	8
3110-00-726-0619	12	51	5961-00-985-4900	5	40
6625-00-738-5985	3	1	5961-00-985-4900	5	82
5961-00-752-6081	6	12	5961-00-985-4900	15	64
5910-00-763-4038	11	35	5910-00-993-2201	6	44
5950-00-764-3186	11	25	5910-00-993-2201	8	3
5905-00-820-4357	5	64	5910-00-993-2201	17	33
5330-00-824-9130	26	40	5120-00-995-9045	4	12
5330-00-824-9130	27	24	5961-00-999-5134	9	9
5330-00-824-9130	30	31			

LATEST PART NUMBER ASSIGNMENTS

PART NUMBER	FSCM	FIG NO	ITEM NO	PART NUMBER	FSCM	FIG NO	ITEM NO
AB396-1	12615	10	49	MS51960-64	96906	23	7
CK06BX104K	81349	10	50	PW7-15000PORM10PCT	07716	15	31
CL31BX3R3LPE	81349	13	9				
CM05F271J03	81349	16	14	SKT41WHITE	98291	24	5
CSR13E476KL	81349	6	44	SKT41WHITE	98291	25	22
CSR13E476KL	81349	8	3	SKT41WHITE	98291	26	1
CSR13E476KL	81349	17	33	SKT41WHITE	98291	27	1
CX10186ARC51X6FT	80058	3	1	SKT41WHITE	98291	28	1
				SKT41WHITE	98291	29	1
DBMF25S	71468	35	5	SKT41WHITE	98291	30	3
DB-24659	71768	35	1	SKT41WHITE	98291	31	1
DM10F100J05004CR	72136	10	62	012-1194-00	13499	18	12
DM10-200J	72136	10	59	050	08664	4	13
F1913-101	72656	10	5	1N3025	81349	17	29
				1108	86376	13	32
GGGK275	81348	4	12	1163S50-125VDC3	86376	5	33
JAN1N270	81349	16	13	213-141216-00-2303	78189	26	40
JAN1N2990B	81349	9	17	213-141216-00-2303	78189	27	24
MIL-S-19500/74	81349	8	9	213-141216-00-2303	78189	30	31
MIL-S-19500/99	98978	6	14	213-141216-00-2303	78189	31	11
MIL-S-19500/99	98978	8	16	224P1-503	80294	5	64
MIL-S-15900/99	98978	17	4	24A	76545	40	5
MS35649-225	96906	6	25	26	76545	40	6
MS35649-225	96906	7	6	310009500	70117	5	26
MS35649-225	96906	9	10	310009500	70117	9	7
MS35649-225	96906	11	24	310009500	70117	15	8
MS35649-225	96906	12	69	310-0100-000	13499	15	20
MS35649-225	96906	13	20	334-0043-000	13499	16	2
MS35649-225	96906	16	18	374NP0125-DEGC10PPFORM1-OPF	72982	10	51
MS35649-225	96906	17	16	47254-68	80020	11	32
MS35649-264	96906	9	4	652025-0644102M	83021	11	3
MS51957-17	96906	12	55				

ADDITIONAL NATIONAL STOCK NUMBER ASSIGNMENTS

STOCK NUMBER	FIGURE NO.	ITEM NO.
5961-00-080-8752	8	9
5310-00-190-7693	40	4
5955-00-738-6145	10	36
5955-00-738-6145	11	38
8105-00-753-4589	4	19
5935-00-845-2537	15	36
5310-00-883-5931	5	15
5310-00-883-5931	15	39
5310-00-883-5931	18	23
5310-00-907-0959	1	14
5310-00-907-0959	12	37
5310-00-907-0959	18	16
5310-00-907-0959	24	18
5310-00-907-0959	25	20
5310-00-907-0959	26	31
5310-00-907-0959	27	31
5310-00-907-0959	28	8
5310-00-907-0959	29	9
5310-00-907-0959	30	11
5310-00-907-0959	31	24
6625-00-935-8641	3	13

ADDITIONAL PART NUMBER ASSIGNMENTS

PART NUMBER	FSCM	FIG. NO.	ITEM NO.
JAN2N657	81349	6	12
MS18130-2	96906	11	25
MS18130-2	96906	16	15
MS35650-305	96906	13	2
U29BU	80058	3	10
024-0137-00	13499	4	19
410894-38	96214	5	15
410894-38	96214	15	39
410894-38	96214	18	23

RECOMMENDED CHANGES TO EQUIPMENT TECHNICAL MANUALS



SOMETHING WRONG WITH THIS MANUAL?

THEN... JOT DOWN THE DOPE ABOUT IT ON THIS FORM, TEAR IT OUT, FOLD IT AND DROP IT IN THE MAIL!

FROM: (YOUR UNIT'S COMPLETE ADDRESS)

Commander
Stateside Army Depot
ATTN: AMSTA-US
Stateside, N.J. 07703

DATE 10 July 1975

PUBLICATION NUMBER

TM 11-5840-340-20P

DATE

23 Jan 78

TITLE

Radar Set AN/PRC-76

BE EXACT... PIN-POINT WHERE IT IS

IN THIS SPACE TELL WHAT IS WRONG AND WHAT SHOULD BE DONE ABOUT IT:

PAGE NO.	PARA-GRAPH	FIGURE NO.	TABLE NO.
33			
44		19	
45			

For item 2, change the NSN to read: 5835-00-134-9186.
Reason: Accuracy.

Identify the cover on the junction box (item no. 5).
Reason: It is a separate item and is not called out on figure 19.

Add the cover of the junction box as an item in the listing for figure 19.
Reason: Same as above.

TEAR ALONG DOTTED LINE

AMST

TYPED NAME, GRADE OR TITLE, AND TELEPHONE NUMBER

SSG I. M. DeSpirito 999-1776

SIGN HERE:

SSG I. M. DeSpirito

DA FORM 2028-2
1 AUG 74

P.S.--IF YOUR OUTFIT WANTS TO KNOW ABOUT YOUR MANUAL "FIND," MAKE A CARBON COPY OF THIS AND GIVE IT TO YOUR HEADQUARTERS.



SOMETHING WRONG WITH THIS MANUAL?

THEN... JOT DOWN THE DOPE ABOUT IT ON THIS FORM, TEAR IT OUT, FOLD IT AND DROP IT IN THE MAIL!

FROM: (YOUR UNIT'S COMPLETE ADDRESS)

DATE

PUBLICATION NUMBER

TM 11-6625-564-40P

DATE

15 MAR 79

TITLE

Maint. Kits, Elec Equipment
MK-731/ARC-51X & MK-731A/ARC-51X

BE EXACT... PIN-POINT WHERE IT IS

PAGE NO.	PARA-GRAPH	FIGURE NO.	TABLE NO.

IN THIS SPACE TELL WHAT IS WRONG AND WHAT SHOULD BE DONE ABOUT IT:

TEAR ALONG DOTTED LINE

TYPED NAME, GRADE OR TITLE, AND TELEPHONE NUMBER

SIGN HERE:

DA FORM 2028-2
1 AUG 74

P.S.--IF YOUR OUTFIT WANTS TO KNOW ABOUT YOUR MANUAL "FIND," MAKE A CARBON COPY OF THIS AND GIVE IT TO YOUR HEADQUARTERS.

FILL IN YOUR
UNIT'S ADDRESS

FOLD BACK

DEPARTMENT OF THE ARMY

OFFICIAL BUSINESS

PENALTY FOR PRIVATE USE, \$300

POSTAGE AND FEES PAID
DEPARTMENT OF THE ARMY
DOG-314



Commander
US Army Communications and
Electronics Materiel Readiness Command
ATTN: DRSEL-ME-MQ
Fort Monmouth, New Jersey 07703

TEAR ALONG DOTTED LINE

FOLD BACK

REVERSE OF DA FORM 2028-2

RECOMMENDED CHANGES TO EQUIPMENT TECHNICAL MANUALS



SOMETHING WRONG WITH THIS MANUAL?

THEN... JOT DOWN THE DOPE ABOUT IT ON THIS FORM, TEAR IT OUT, FOLD IT AND DROP IT IN THE MAIL!

FROM: (YOUR UNIT'S COMPLETE ADDRESS)

DATE

PUBLICATION NUMBER

TM 11-6625-564-40P

DATE

15 MAR 79

TITLE

Maint. Kits, Elec Equipment
MK-731/ARC-51X & MK-731A/ARC-51X

BE EXACT... PIN-POINT WHERE IT IS

PAGE NO.

PARA-GRAPH

FIGURE NO.

TABLE NO.

IN THIS SPACE TELL WHAT IS WRONG AND WHAT SHOULD BE DONE ABOUT IT:

TEAR ALONG DOTTED LINE

TYPED NAME, GRADE OR TITLE, AND TELEPHONE NUMBER

SIGN HERE:

DA FORM 2028-2
1 AUG 74

P.S.--IF YOUR OUTFIT WANTS TO KNOW ABOUT YOUR MANUAL "FIND," MAKE A CARBON COPY OF THIS AND GIVE IT TO YOUR HEADQUARTERS.

FILL IN YOUR
UNIT'S ADDRESS

FOLD BACK

DEPARTMENT OF THE ARMY

OFFICIAL BUSINESS

PENALTY FOR PRIVATE USE, \$300

POSTAGE AND FEES PAID
DEPARTMENT OF THE ARMY
DOD-314



Commander
US Army Communications and
Electronics Materiel Readiness Command
ATTN: DRSEL-ME-MQ
Fort Monmouth, New Jersey 07703

TEAR ALONG DOTTED LINE

FOLD BACK

REVERSE OF DA FORM 2026-2



SOMETHING WRONG WITH THIS MANUAL?

THEN... JOT DOWN THE DOPE ABOUT IT ON THIS FORM, TEAR IT OUT, FOLD IT AND DROP IT IN THE MAIL!

FROM: (YOUR UNIT'S COMPLETE ADDRESS)

DATE

PUBLICATION NUMBER

TM 11-6625-564-40P

DATE

15 MAR 79

TITLE

Maint. Kits, Elec Equipment
MK-731/ARC-51X & MK-731A/ARC-51X

BE EXACT... PIN-POINT WHERE IT IS

PAGE NO.

PARA-GRAPH

FIGURE NO.

TABLE NO.

IN THIS SPACE TELL WHAT IS WRONG AND WHAT SHOULD BE DONE ABOUT IT:

TEAR ALONG DOTTED LINE

TYPED NAME, GRADE OR TITLE, AND TELEPHONE NUMBER

SIGN HERE:

DA FORM 2028-2
1 AUG 74

P.S.--IF YOUR OUTFIT WANTS TO KNOW ABOUT YOUR MANUAL "FIND," MAKE A CARBON COPY OF THIS AND GIVE IT TO YOUR HEADQUARTERS.

FILL IN YOUR
UNIT'S ADDRESS

FOLD BACK

DEPARTMENT OF THE ARMY

POSTAGE AND FEES PAID
DEPARTMENT OF THE ARMY
DOD-314



OFFICIAL BUSINESS
PENALTY FOR PRIVATE USE, \$300

Commander
US Army Communications and
Electronics Materiel Readiness Command
ATTN: DRSEL-ME-MQ
Fort Monmouth, New Jersey 07703

TEAR ALONG DOTTED LINE

FOLD BACK

By Order of the Secretary of the Army:

BERNARD W. ROGERS
General, United States Army
Chief of Staff

Official:

J. C. PENNINGTON
Major General, United States Army
The Adjutant General

DISTRIBUTION:

To be distributed in accordance with DA Form 12-36, Direct and General Support maintenance requirements for AN/ARC-51.

DEPARTMENT OF THE ARMY
US ARMY AG PUBLICATIONS CENTER
1655 WOODSON ROAD
ST. LOUIS, MISSOURI 63114
OFFICIAL BUSINESS
PENALTY FOR PRIVATE USE \$300

POSTAGE AND FEES PAID
DEPARTMENT OF THE ARMY
DOD 314

